



FRONT RANGE FIRE APPARATUS

**7600 Miller Court
Frederick, CO 80504
303-449-9911
1-800-334-9911
www.FrontRangeFire.com**

**JASON BYRNE
303-929-0079
jasonb@frontrangefire.com**



PERFORM. LIKE NO OTHER.™

NEDERLAND FIRE PROTECTION DISTRICT PIERCE SABER 4X4 ENGINE BID #1177

1. PROPOSAL PRICING
2. MAIN PROPOSAL
3. COMPONENT LIST, ELECTRICAL ANALYSIS, TURN REPORT, WEIGHT REPORT, DRAWING
4. WARRANTIES
5. CERTIFICATIONS AND TECHNICAL INFORMATION
6. PIERCE MANUFACTURING, LICENSE & INSURANCE CERTIFICATE OF GOOD STANDING
7. FRONT RANGE FIRE APPARATUS, LICENSE & INSURANCE
8. LITERATURE

NO REGRETS WHEN
YOU CHOOSE
PIERCE.



A LOT'S RIDING ON YOUR INVESTMENT.

The safety of firefighters and families, the security of property and the well-being of the entire community depend on your decision. Lives and reputations ride on your investment. Make sure help is always on the way.

Go with longevity. Go with the #1 industry authority that protects the legacies great community leaders leave behind. When you invest in Pierce® fire apparatus, you're making the right call for the long haul.



No other manufacturer has a stronger foundation of expertise, stability and support.

Unmatched Support

- Over 35 years in business
- Staffed by 7 sales professionals with 150 years of combined experience
- State-of-the-art service center employs a team of highly trained and certified technicians
- Mobile services and a full line of parts and equipment

Untouchable Fire Apparatus Expertise

- Over 30,000 custom chassis built
- More than 30 patents attributed to our continued investment in research, development and safety
- Thousands of years of cumulative experience
- First single-source manufacturer of custom fire apparatus in North America to achieve ISO 9001 certification
- Only manufacturer to have third party, Underwriters Laboratories certification on the entire apparatus

Unshakable Stability

- Rock-solid financials as an Oshkosh Corporation Company
- Oshkosh named a World's Most Ethical Company by Ethisphere Institute
- Recognized as a 2016 Best Governance, Risk, and Compliance Program by NYSE Governance Services
- Complete transparency of a public traded company
- Greater strength from shared engineering and technology across all of Oshkosh Corporation
- With over 100 years of history and numerous industry-first contributions, we're not going anywhere
- America's Best Large Employers list by Forbes



200+
FULL-TIME
ENGINEERS

PIERCE

3RD PARTY
CERTIFIED
NFPA
1901-2009

PIERCE



**OVER 13,000
EMPLOYEES
WORLDWIDE**

OSHKOSH

**ISO 9001
CERTIFICATION**

PIERCE & OSHKOSH



**GLOBALLY
USED
PATENTS**

OSHKOSH



2016 WORLD'S MOST
ETHICAL
COMPANIES
WWW.ETHISPHERE.COM

#1
RESEARCH,
DEVELOPMENT
& SAFETY

PIERCE

1,600+
MANUFACTURING
EMPLOYEES

PIERCE



**UL/ULC
CERTIFIED**

PIERCE & OSHKOSH

**SINGLE
SOURCE**

PIERCE

\$9M
PARTS
INVENTORY

PIERCE



**24/7
RESPONSE**

FRONT RANGE
FIRE APPARATUS



VOLUNTEER & COMBINATION
OFFICERS SECTION

Pierce leads the industry in sponsorships that support families of fallen firefighters, recognize outstanding achievement and further the education and safety of the fire service.

www.piercemfg.com



Pierce Manufacturing Inc., An Oshkosh Corporation Company
P.O. Box 2017, Appleton WI 54912-2017 USA



Specifications, descriptions and illustrative material in this literature are as accurate as known at the time of publication, but are subject to change without notice.

Illustrations may include optional equipment and accessories and may not include all standard equipment. All measurements are nominal values.

© Pierce Manufacturing Inc., Pierce and the Pierce logo are registered trademarks of Pierce Manufacturing Inc., Appleton, WI.

Printed in U.S.A.

All other trademarks are the property of their respective owners.

P-0108-SLLSTBLTYSS-FRNTRNG 1/17

PROPOSAL FOR FURNISHING FIRE APPARATUS

November 11, 2022

Nederland Fire Protection District
650 W 4th St.
Nederland, CO 80466

The undersigned is prepared to manufacture for you, upon an order being placed by you, for final acceptance by Front Range Fire Apparatus., at its home office in Frederick, Colorado, the apparatus, and equipment herein named and for the following prices:

(1) One Pierce Saber 4x4 Engine Per Bid #1177	\$886,211.00
Note: Pricing per HGAC	
Optional 100% Performance Bond	\$2,172.00
(Note: Required for Pre-Payment options)	
Optional Discount for 100% Pre-Payment of \$858,398.00	Deduct (\$29,985.00)
(Note: Requires and Includes Performance Bond)	
(Note: Net due within 30 days of contract signing)	
Total	_____

Said apparatus and equipment are to be built and shipped in accordance with the specifications hereto attached, delays due to strikes, war, or intentional conflict, failures to obtain chassis, materials, or other causes beyond our control not preventing, within about 21 months after receipt of this order and the acceptance thereof at our office at Frederick, Colorado, and to be delivered to you in Nederland, CO.

The specifications herein contained shall form a part of the final contract, and are subject to changes desired by the purchaser, provided such alterations are interlined prior to the acceptance by the company of the order to purchase, and provided such alterations do not materially affect the cost of the construction of the apparatus.

The proposal for fire apparatus conforms with all Federal Department of Transportation (DOT) rules and regulations in effect at the time of bid, and with all National Fire Protection Association (NFPA) Guidelines for Automotive Fire Apparatus as published at the time of bid, except as modified by customer specifications. Any increased costs incurred by first party because of future changes in or additions to said DOT or NFPA standards will be passed along to the customers as an addition to the price set forth above.

Unless accepted within 30 days from date, the right is reserved to withdraw this proposition.

FRONT RANGE FIRE APPRATUS.

By: _____

Jason Byrne
SALES REPRESENTATIVE





Nederland Fire Protection District Pierce 4x4 Saber Engine Bid #1177 Bid Notes

Service and Warranty Support: Dealership

-Front Range Fire Apparatus is 38 road miles from Nederland, CO.
-Front Range Fire Apparatus is staffed with EVT certified technicians, a Master EVT certified technician, a mobile EVT certified technician, a service manager, two dedicated parts support personnel, and additional support personnel. Please see the “Front Range Fire Apparatus” tab of our bid for additional information on service, mobile service, parts support, and certifications of our technicians.

Mobile Service and Warranty Support: Dealership

-Front Range Fire Apparatus is 38 road miles from Nederland, CO.
-Front Range Fire Apparatus is staffed with EVT certified technicians, a Master EVT certified technician, a mobile EVT certified technician, a service manager, two dedicated parts support personnel, and additional support personnel. Please see the “Front Range Fire Apparatus” tab of our bid for additional information on service, mobile service, parts support, and certifications of our technicians.

Parts Support: Dealership

-Front Range Fire Apparatus is staffed with EVT certified technicians, a Master EVT certified technician, a mobile EVT certified technician, a service manager, two dedicated parts support personnel, and additional support personnel. Please see the “Front Range Fire Apparatus” tab of our bid for additional information on service, mobile service, parts support, and certifications of our technicians.

Included in Proposal: Pre Build Trip #1

An inspection trip shall be provided for up to 3 people. Trip is to take place at the main manufacturing facility.

The successful bidder is responsible for air fare, ground travel, lodging, and all other costs associated with this trip.

7600 Miller Court
Frederick West Business Park
Frederick, Colorado 80504
303-449-9911 800-334-9911 fax 303-532-2486

fronrangefire.com





Included in Proposal: Final Inspection Trip #2

An inspection trip shall be provided for up to 3 people. Trip is to take place at the main manufacturing facility.

The successful bidder is responsible for air fare, ground travel, lodging, and all other costs associated with this trip.

Delivery Date

-The proposed time to completed first unit for inspection is 21 months from order to final inspection.

-Due to global supply chain constraints, any delivery date contained herein is a good faith estimate as of the date of this order/contract, and merely an approximation based on current information. Delivery updates will be made available, and a final firm delivery date will be provided as soon as possible.

Include in Proposal: Contingency Fund, For Equipment Mounting and Changes

A \$5,000 contingency fund shall be included in the bid price. Any and all amount of the contingency fund not used during the final design of the apparatus shall be refunded to the purchaser and listed as so on the final invoice.

This fund is for changes requested by the bidder during the build process but after the bid.

This fund is for equipment mounting to be provided by the successful bidder. Equipment mounting is to be charged to the fund as time and materials. Time is to be the successful bidders published shop labor rater. Materials are to be at or below manufactures MSRP for the materials and/or mounts.

All changes and or labor utilizing the contingency fund is to be approved by the purchaser prior to use of those funds.

7600 Miller Court
Frederick West Business Park
Frederick, Colorado 80504
303-449-9911 800-334-9911 fax 303-532-2486

fronrangefire.com



CONTENTS

GENERAL DESIGN AND CONSTRUCTION.....	16
QUALITY AND WORKMANSHIP.....	16
DELIVERY	17
MANUAL AND SERVICE INFORMATION.....	17
SAFETY VIDEO	17
PERFORMANCE TESTS.....	17
SERVICE AND WARRANTY SUPPORT	17
LIABILITY	18
INSURANCE PROVIDED BY BIDDER.....	18
COMMERCIAL GENERAL LIABILITY INSURANCE	18
COMMERCIAL AUTOMOBILE LIABILITY INSURANCE.....	19
UMBRELLA/EXCESS LIABILITY INSURANCE.....	19
INSURANCE PROVIDED BY MANUFACTURER	19
PRODUCT LIABILITY INSURANCE	19
UMBRELLA/EXCESS LIABILITY INSURANCE.....	20
SINGLE SOURCE MANUFACTURER.....	20
NFPA 2016 STANDARDS.....	20
NFPA COMPLIANCY	21
PUMP TEST	21
GENERATOR TEST	21
WEEKLY PROGRESS REPORTS.....	21
APPARATUS MANUFACTURER	21
AFTERMARKET SUPPORT WEBSITE	21
BID BOND NOT REQUESTED	23
PERFORMANCE BOND, 1 YEAR	23
APPROVAL DRAWING.....	23
ELECTRICAL WIRING DIAGRAMS.....	24
SABER FR CHASSIS.....	24
WHEELBASE	24
GVW RATING	24
FRAME.....	24

FRONT AXLE.....	24
FRONT SUSPENSION	24
SHOCK ABSORBERS	25
GREASE SEALS.....	25
DRIVER CONTROL DIFFERENTIAL LOCK (DCDL).....	25
FRONT TIRES	25
REAR AXLE	25
TOP SPEED OF VEHICLE	25
REAR SUSPENSION.....	25
REAR OIL SEALS.....	26
DRIVER CONTROL DIFFERENTIAL LOCK (CTD).....	26
REAR TIRES.....	26
TIRE BALANCE	26
TIRE PRESSURE MANAGEMENT.....	26
CHROME LUG NUT COVERS	26
MUD FLAPS.....	26
AIR PRESSURE TIRE EQUALIZATION	26
WHEEL CHOCKS	26
Wheel Chock Brackets	26
ANTI-LOCK BRAKE SYSTEM	27
ELECTRONIC STABILITY CONTROL.....	27
AUTOMATIC TRACTION CONTROL	27
BRAKES.....	27
BRAKE SYSTEM AIR COMPRESSOR	28
BRAKE SYSTEM	28
BRAKE SYSTEM AIR DRYER.....	28
BRAKE LINES.....	28
AIR INLET WITH AUTOMATIC EJECT	28
ADDITIONAL AIR TANK.....	29
AUTOMATIC MOISTURE EJECTORS	29
ENGINE	29
HIGH IDLE	30
ENGINE BRAKE	30

CLUTCH FAN.....	30
ENGINE AIR INTAKE.....	30
EXHAUST SYSTEM.....	30
RADIATOR.....	31
COOLANT LINES.....	31
FUEL TANK.....	31
DIESEL EXHAUST FLUID TANK.....	32
FUEL PRIMING PUMP	32
TRANSMISSION.....	32
TRANSMISSION SHIFTER.....	32
TRANSMISSION COOLER.....	33
DOWNSHIFT MODE (w/engine brake).....	33
DRIVELINE	33
STEERING.....	33
STEERING WHEEL	33
LOGO AND CUSTOMER DESIGNATION ON DASH.....	33
FRONT WINCH.....	33
BUMPER.....	34
GRAVEL PAN.....	34
TOW EYES	34
CAB.....	35
CAB ROOF DRIP RAIL.....	36
INTERIOR CAB INSULATION	36
FENDER LINERS.....	36
PANORAMIC WINDSHIELD.....	36
WINDSHIELD WIPERS.....	36
ENGINE TUNNEL	37
INTERIOR CREW CAB REAR WALL ADJUSTABLE SEATING (PATENT PENDING).....	37
CAB REAR WALL EXTERIOR COVERING.....	38
CAB LIFT	38
Cab Lift Interlock.....	39
GRILLE	39
MIRRORS	39

DOORS	39
Door Panels	40
MANUAL CAB DOOR WINDOWS	40
CAB STEPS	40
CAB EXTERIOR HANDRAILS	41
STIRRUP STEPS	41
STEP LIGHTS	41
FENDER CROWNS	41
CREW CAB WINDOWS	41
CUP HOLDER	41
CAB DASH	42
MOUNTING PLATE ON ENGINE TUNNEL	42
MOUNTING PLATE(S)	42
CAB INTERIOR	42
CAB INTERIOR UPHOLSTERY	43
CAB INTERIOR PAINT	43
CAB FLOOR	43
DEFROST/AIR CONDITIONING SYSTEM	43
Cab Defroster	43
Cab/Crew Auxiliary Heater	43
Air Conditioning	43
Climate Control	44
Gravity Drain Tubes	45
WINDOW DEFROST FANS	45
SUN VISORS	45
GRAB HANDLES	45
ENGINE COMPARTMENT LIGHT	45
ACCESS TO ENGINE DIPSTICKS	45
STORAGE BOX	46
MAP BOX	46
CAB SAFETY SYSTEM	46
Frontal Impact Protection	46
Side Roll Protection	47

SEATING CAPACITY.....	47
DRIVER SEAT	47
OFFICER SEAT	48
RADIO COMPARTMENT	48
REAR FACING DRIVER SIDE OUTBOARD SEAT	48
REAR FACING PASSENGER SIDE OUTBOARD SEAT	49
FORWARD FACING CENTER CABINET	49
Cabinet Light	49
MATTING IN EMS COMPARTMENT.....	49
SEAT UPHOLSTERY.....	50
AIR BOTTLE HOLDERS.....	50
SEAT BELTS.....	50
HELMET STORAGE PROVIDED BY FIRE DEPARTMENT.....	50
CAB DOME LIGHTS	50
HAND HELD LIGHT	51
HAND HELD LIGHT	51
CAB INSTRUMENTATION	51
Gauges	51
Indicator Lamps	52
Alarms	53
Indicator Lamp and Alarm Prove-Out	53
Control Switches.....	53
Custom Switch Panels.....	54
Diagnostic Panel.....	55
AIR RESTRICTION INDICATOR	56
"DO NOT MOVE APPARATUS" INDICATOR.....	56
SWITCH PANELS	56
WIPER CONTROL.....	56
SPARE CIRCUIT.....	56
SPARE CIRCUIT.....	56
CUSTOMER SUPPLIED RADIO WIRING	57
INFORMATION CENTER	57
COLLISION MITIGATION	57

VEHICLE DATA RECORDER.....	58
Seat Belt Monitoring System	58
INTERCOM SYSTEM	58
RADIO / INTERCOM INTERFACE INCLUDED	59
UNDER THE HELMET HEADSET	59
OVER THE HEAD HEADSET	59
HEADSET HANGERS.....	59
RADIO ANTENNA MOUNT.....	60
VEHICLE CAMERA SYSTEM.....	60
VEHICLE CAMERA GUARD.....	60
ELECTRICAL POWER CONTROL SYSTEM	60
VOLTAGE MONITOR SYSTEM.....	61
POWER AND GROUND STUDS	61
EMI/RFI PROTECTION.....	61
ELECTRICAL	61
BATTERY SYSTEM.....	62
BATTERY SYSTEM.....	63
MASTER BATTERY SWITCH.....	63
BATTERY COMPARTMENTS	63
JUMPER STUDS	63
BATTERY CHARGER.....	63
SHORELINE INLET	63
ELECTRIC POWER FOR WINCH	64
ALTERNATOR	64
ELECTRONIC LOAD MANAGEMENT.....	64
HEADLIGHTS	64
FRONT DIRECTIONALS	64
INTERMEDIATE LIGHT	65
CAB CLEARANCE/MARKER/ID LIGHTS	65
FRONT CAB SIDE DIRECTIONAL/MARKER LIGHTS.....	65
REAR CLEARANCE/MARKER/ID LIGHTING	65
REAR FMVSS LIGHTING	66
LICENSE PLATE BRACKET.....	66

LIGHTING BEZEL	66
BACK-UP ALARM	66
SWITCH, BACK-UP ALARM OVERRIDE	66
CAB PERIMETER SCENE LIGHTS	67
PUMP HOUSE PERIMETER LIGHTS	67
BODY PERIMETER SCENE LIGHTS	67
ADDITIONAL PERIMETER LIGHTS	67
STEP LIGHTS	67
12 VOLT LIGHTING	68
12 VOLT LIGHTING	68
12 VOLT LIGHTING	68
12 VOLT LIGHTING	68
12 VOLT LIGHTING	69
HOUSING TO MOUNT RECESSED LIGHT ONTO A HORIZONTAL SURFACE	69
12 VOLT LIGHTING	69
HOSE BED LIGHTS	69
WALKING SURFACE LIGHT	69
FRONT WHITE WARNING LIGHT CONTROL	70
SWITCH, RED	70
WATER TANK	70
SLEEVE, PLUMBING, THROUGH TANK	71
WATER TANK RESTRAINT	71
HOSE BED	71
HOSE BED DIVIDER	72
CUTOUT, HANDHOLD	72
REINFORCED HOSEBED FLOOR	72
HOSE BED COVER	72
RUNNING BOARDS	72
TAILBOARD	73
REAR WALL, SMOOTH ALUMINUM/BODY MATERIAL	73
REAR TOW EYES	73
RUNNING BOARD HOSE RESTRAINT	73
RUNNING BOARD HOSE RESTRAINT	73

HOSE TRAY.....	74
EXTINGUISHER BIN IN HOSE TRAY	74
COMPARTMENTATION	74
UNDERBODY SUPPORT SYSTEM	74
AGGRESSIVE WALKING SURFACE	75
LOUVERS	75
TESTING OF BODY DESIGN	75
LEFT SIDE COMPARTMENTATION	76
RIGHT SIDE COMPARTMENTATION.....	77
SIDE COMPARTMENT ROLLUP DOOR(S).....	78
REAR COMPARTMENTATION	78
ROLLUP REAR COMPARTMENT DOOR.....	79
PULL STRAP, DOORS	79
SCUFFPLATE.....	79
DOOR GUARD.....	79
ROLL-UP DOOR TRIM	80
COMPARTMENT LIGHTING	80
MOUNTING TRACKS	80
ADJUSTABLE SHELVES.....	80
SLIDE-OUT FLOOR MOUNTED TRAY	80
PARTITION, TRANSVERSE REAR COMPARTMENT.....	81
MOUNTING PLATE	81
MATTING, COMPARTMENT FLOOR.....	81
MATTING, COMPARTMENT SHELVING.....	81
RUB RAIL.....	81
BODY FENDER CROWNS	81
BODY FENDER LINER.....	81
HARD SUCTION HOSE.....	81
HARD SUCTION HOSE COMPARTMENT.....	82
HANDRAILS.....	82
HANDRAILS.....	82
EXTINGUISHER/AIR BOTTLE/ STORAGE (Triangular).....	82
AIR BOTTLE COMPARTMENT STRAP	82

AIR BOTTLE STORAGE (Double).....	82
AIR BOTTLE COMPARTMENT STRAP	83
AIR BOTTLE STORAGE (Triple)	83
AIR BOTTLE COMPARTMENT STRAP	83
EXTENSION LADDER.....	83
ROOF LADDER	83
LADDER RACK.....	83
LADDER RACK INTERLOCK AND NOT STOWED INDICATOR LIGHT	83
LIGHTS, FLASHING, HYD LADDER RACK	84
LADDER STORAGE, FOLDING LADDER.....	84
FOLDING LADDER.....	84
4' PIKE POLE.....	84
8' PIKE POLE.....	84
8' COLORADO HOOK PIKE POLE.....	84
6 FT PIKE POLE	84
PIKE POLE STORAGE.....	84
PIKE POLE MOUNTING.....	84
PIKE POLE STORAGE.....	84
FOLDING STEPS FRONT OF BODY	85
REAR FOLDING STEPS.....	85
STEP, PULL-OUT/DROP DOWN	85
I-ZONE BRACKETS - WILDLAND STYLE.....	85
PUMP COMPARTMENT.....	85
PUMP MOUNTING	86
LEFT SIDE PUMP CONTROL PANEL	86
IDENTIFICATION TAGS.....	86
PUMP	86
PUMP TRANSMISSION.....	87
PUMPING MODE.....	88
PUMP SHIFT.....	88
AUXILIARY COOLING SYSTEM	88
TRANSFER VALVE	88
INTAKE RELIEF VALVE	88

PRIMING PUMP.....	90
AIR BLOWOUT VALVE.....	90
RECIRCULATING LINE WITH CHECK VALVE.....	90
THERMAL RELIEF VALVE.....	91
PUMP MANUALS.....	91
PUMP TEST.....	91
PLUMBING, STAINLESS STEEL AND HOSE.....	91
FOAM SYSTEM PLUMBING	91
MAIN PUMP INLETS	92
INLET BUTTERFLY VALVE.....	92
INLET BUTTERFLY VALVE.....	92
MAIN PUMP INLET CAP PROVIDED BY FIRE DEPARTMENT.....	93
VALVES	93
INLET CONTROL.....	93
LEFT SIDE INLET	93
RIGHT SIDE INLET.....	93
ANODE, INLET	93
ELBOW, REAR INLET	93
ELBOW, FRONT INLET	93
INLET BLEEDER VALVE.....	93
TANK TO PUMP	94
TANK REFILL.....	94
DISCHARGE OUTLET CONTROLS.....	94
LEFT SIDE DISCHARGE OUTLETS	94
LEFT SIDE OUTLET ELBOWS.....	94
RIGHT SIDE DISCHARGE OUTLETS.....	95
RIGHT SIDE OUTLET ELBOWS	95
ADDITIONAL RIGHT SIDE OUTLET ELBOWS.....	95
ADDITIONAL FRONT DISCHARGE OUTLET & ACCESSORIES	95
REAR DISCHARGE OUTLET.....	95
REAR OUTLET ELBOWS.....	95
DISCHARGE CAPS/ INLET PLUGS.....	95
OUTLET BLEEDER VALVE.....	96

DELUGE RISER.....	96
DELUGE OUTLET SPECIAL INSTRUCTIONS	96
MONITOR	96
CROSSLAY HOSE BEDS.....	96
CROSSLAY/DEADLAY HOSE RESTRAINT	97
CROSSLAY COVER.....	97
CROSSLAY 8.00" LOWER THAN STANDARD.....	97
BOOSTER HOSE REEL	97
HOSE REEL BLOWOUT.....	98
Cover.....	98
HUSKY 3 FOAM PROPORTIONER	98
System Capacity.....	98
Control System	98
Hydraulic Drive System	99
Foam Concentrate Pump	99
External Foam Concentrate Connection.....	99
Panel Mounted External Pick-Up Connection / Valve.....	100
Pick-Up Hose.....	100
Discharges.....	100
System Electrical Load	100
SINGLE FOAM TANK REFILL	100
FOAM TANK	100
FOAM TANK DRAIN	100
DRAWING, PUMP OPERATOR'S PANEL	100
PUMP PANEL CONFIGURATION	100
PUMP AND GAUGE PANEL.....	101
PUMP ACCESS	101
Right Side Panel.....	101
Panel Fastener	101
Front Pump House Access.....	101
PUMP COMPARTMENT LIGHT	101
THROTTLE READY GREEN INDICATOR LIGHT.....	101
OK TO PUMP INDICATOR LIGHT	101

AIR HORN SWITCH.....	101
DRAINS, ABOVE RUNNING BOARDS, LS & RS.....	101
ELECTRIC GAUGE HEATER.....	102
HEATER, PUMP COMPARTMENT	102
RUBBER SEAL AROUND PUMP PANEL OPENINGS	102
VACUUM AND PRESSURE GAUGES.....	102
PRESSURE GAUGES	102
WATER LEVEL GAUGE	102
MINI SLAVE UNIT.....	103
WATER LEVEL GAUGE.....	103
FOAM LEVEL GAUGE.....	103
STEP/LIGHT SHIELD	104
AIR HORN SYSTEM.....	104
Air Horn Location.....	104
Air Horn Control.....	104
ELECTRONIC SIREN	104
ELECTRONIC SIREN CONTROL.....	104
SPEAKERS.....	105
LIGHTBAR, Cab Roof.....	105
FRONT ZONE LOWER LIGHTS.....	105
HEADLIGHT FLASHER	105
SIDE ZONE LOWER LIGHTING.....	106
REAR ZONE LOWER LIGHTING	106
REAR/SIDE ZONE UPPER WARNING LIGHTS	106
TRAFFIC DIRECTING LIGHT.....	106
ELECTRICAL SYSTEM GENERAL DESIGN for ALTERNATING CURRENT	107
General.....	107
Grounding.....	107
Operation.....	108
Overcurrent protection	108
Wiring Methods.....	108
Wiring Identification	109
Wet Locations.....	109

Dry Locations.....	109
Listing	109
Electrical System Testing	109
Operational Test per Current NFPA 1901 Standard.....	110
GENERATOR.....	110
GENERATOR LOCATION	112
GENERATOR START	112
CIRCUIT BREAKER PANEL.....	112
GENERATOR COVER OVER PUMP	112
ELECTRIC CORD REEL.....	112
CORD.....	112
CORD.....	112
PORTABLE JUNCTION BOX	113
120 VOLT RECEPTACLE.....	113
120 VOLT RECEPTACLE	113
120 VOLT RECEPTACLE	113
NFPA REQUIRED LOOSE EQUIPMENT PROVIDED BY FIRE DEPARTMENT	114
SOFT SUCTION HOSE	115
DRY CHEMICAL EXTINGUISHER	115
WATER EXTINGUISHER	115
FLATHEAD AXE PROVIDED BY FIRE DEPARTMENT	115
PICKHEAD AXE PROVIDED BY FIRE DEPARTMENT	115
PAINT PROCESS	115
Environmental Impact.....	116
PAINT.....	117
PAINT CHASSIS FRAME ASSEMBLY	117
PAINT, FRONT WHEELS	118
PAINT, REAR WHEELS.....	118
AXLE HUB PAINT.....	119
FRONT BUMPER COATING	119
TRANSIT COATING.....	119
COMPARTMENT INTERIOR PAINT	119
REFLECTIVE STRIPES.....	119

REAR CHEVRON STRIPING	120
CHEVRON STRIPING ON THE FRONT BUMPER.....	120
CAB DOOR REFLECTIVE STRIPE	120
LETTERING	120
LETTERING	120
LETTERING	120
EMBLEM/S.....	120
Contingency Fund, For Equipment Mounting and Changes	120
1" BOOSTER HOSE NOZZLE	121
INSPECTION TRIP #1	121
INSPECTION TRIP #2	121
FIRE APPARATUS PARTS MANUAL	121
Service Parts Internet Site	121
CHASSIS SERVICE MANUALS	121
CHASSIS OPERATION MANUAL	122
ONE (1) YEAR MATERIAL AND WORKMANSHIP	122
ENGINE WARRANTY	122
STEERING GEAR WARRANTY	122
FIFTY (50) YEAR STRUCTURAL INTEGRITY	122
FRONT AXLE ONE (1) YEAR MATERIAL AND WORKMANSHIP WARRANTY	122
REAR AXLE WARRANTY.....	122
ABS BRAKE SYSTEM THREE (3) YEAR MATERIAL AND WORKMANSHIP WARRANTY	122
TEN (10) YEAR STRUCTURAL INTEGRITY.....	122
TEN (10) YEAR PRO-RATED PAINT AND CORROSION	122
CAMERA SYSTEM WARRANTY.....	122
COMPARTMENT LIGHT WARRANTY	123
TRANSMISSION WARRANTY	123
TRANSMISSION COOLER WARRANTY	123
WATER TANK WARRANTY	123
TEN (10) YEAR STRUCTURAL INTEGRITY.....	123
ROLL UP DOOR MATERIAL AND WORKMANSHIP WARRANTY	123
PUMP WARRANTY	123
TEN (10) YEAR PUMP PLUMBING WARRANTY	123

FOAM SYSTEM WARRANTY.....	123
TWO (2) YEAR GENERATOR MATERIAL AND WORKMANSHIP WARRANTY	123
TEN (10) YEAR PRO-RATED PAINT AND CORROSION	123
ONE (1) YEAR MATERIAL AND WORKMANSHIP	124
VEHICLE STABILITY CERTIFICATION	124
ENGINE INSTALLATION CERTIFICATION	124
POWER STEERING CERTIFICATION.....	124
CAB INTEGRITY CERTIFICATION	124
Side Impact.....	124
Frontal Impact.....	124
Additional Frontal Impact.....	124
Roof Crush	124
Additional Roof Crush.....	125
CAB DOOR DURABILITY CERTIFICATION	125
WINDSHIELD WIPER DURABILITY CERTIFICATION	125
SEAT BELT ANCHOR STRENGTH.....	125
SEAT MOUNTING STRENGTH.....	125
PERFORMANCE CERTIFICATIONS	125
Cab Air Conditioning.....	125
Cab Defroster	125
Cab Auxiliary Heater.....	126
AMP DRAW REPORT.....	126

Front Range Fire Apparatus is pleased to submit a proposal to Nederland Fire Protection District for a **Pierce® triple combination pumper** per your request for quotation. The following paragraphs will describe in detail the apparatus, construction methods, and equipment proposed. This proposal will indicate size, type, model and make of components parts and equipment, providing proof of compliance with each and every item (except where noted) in the departments advertised specifications.

PIERCE MANUFACTURING was founded in 1913. Since then we have been building bodies with one philosophy, "BUILD THE FINEST". Our skilled craftsmen take pride in their work, which is reflected, in the final product. We have been building fire apparatus since the early "forties" giving Pierce Manufacturing over 75 years of experience in the fire apparatus market. Pierce Manufacturing has built and put into service more than 62,500 apparatus, including more than 33,900 on Pierce custom chassis designed and built specifically for fire and emergency applications. Our Appleton, Wisconsin facility has over 870,000 total square feet of floor space situated on approximately 105 acres of land. Our Bradenton, Florida facility has 300,000 square feet of floor space situated on approximately 38 acres of land.

Our beliefs in high ethical standards are carried through in all of our commitments and to everyone with whom we do business. Honesty, Integrity, Accountability and Citizenship are global tenets by which we all live and work. Consequently, we neither engage in, nor have we ever been convicted of price fixing, bid rigging, or collusion in any domestic or international fire apparatus market.

Pierce has only one brand of fire apparatus "Pierce", ensuring you are receiving top of the line product that meets your specification.

In accordance with the current edition of NFPA 1901 standards, this proposal will specify whether the fire department, manufacturer, or apparatus dealership will provide required loose equipment.

Images and illustrative material in this proposal are as accurate as known at the time of publication, but are subject to change without notice. Images and illustrative material is for reference only, and may include optional equipment and accessories and may not include all standard equipment.

GENERAL DESIGN AND CONSTRUCTION

To control quality, ensure compatibility, and provide a single source for service and warranty, the custom cab, chassis, pump module and body will be entirely designed, assembled/welded and painted in Pierce owned manufacturing facilities. This includes, but not limited to the cab weldment, the pumphouse module assembly, the chassis assembly, the body and the electrical system.

QUALITY AND WORKMANSHIP

Pierce has set the pace for quality and workmanship in the fire apparatus field. Our tradition of building the highest quality units with craftsmen second to none has been the rule right from the beginning and we demonstrate that ongoing commitment by: Ensuring all steel welding follows American Welding Society D1.1-2004 recommendations for structural steel welding. All aluminum welding follows American Welding society and ANSI D1.2-2003 requirements for structural welding of aluminum. All sheet metal welding follows American welding Society B2.1-2000 requirements for structural welding of sheet metal. Our flux core arc welding uses alloy rods, type 7000 and is performed to American Welding Society standards A5.20-E70T1. Furthermore, all employees classified as welders are tested

and certified to meet the American welding Society codes upon hire and every three (3) years thereafter. Pierce also employs an American Welding Society certified welding inspector in plant during working hours to monitor weld quality.

Pierce Manufacturing operates a Quality Management System under the requirements of ISO 9001. These standards sponsored by the International Organization for Standardization (ISO) specify the quality systems that are established by the manufacturer for design, manufacture, installation and service. A copy of the certificate of compliance is included with this proposal.

In addition to the Quality Management system, we also employ a Quality Achievement Supplier program to insure the vendors and suppliers that we utilize meet the high standards we demand. That is just part of our overall "Quality at the Source" program at Pierce.

To demonstrate the quality of our products and services, a list of at least five (5) fire departments/municipalities that have purchased vehicles for a second time is provided.

DELIVERY

The apparatus will be delivered under its own power to insure proper break-in of all components while the apparatus is still under warranty. A qualified delivery representative shall deliver the apparatus and remain for a sufficient length of time to instruct personnel in proper operation, care and maintenance of the equipment delivered.

MANUAL AND SERVICE INFORMATION

At time of delivery, complete operation and maintenance manuals covering the apparatus will be provided. A permanent plate will be mounted in the driver's compartment specifying the quantity and type of fluids required including engine oil, engine coolant, transmission, pump transmission lubrication, pump primer and drive axle.

SAFETY VIDEO

At the time of delivery Pierce will also provide one (1) 39-minute, professionally produced apparatus safety video, in DVD format. This video will address key safety considerations for personnel to follow when they are driving, operating, and maintaining the apparatus, including the following: vehicle pre-trip inspection, chassis operation, pump operation, aerial operation, and safety during maintenance.

PERFORMANCE TESTS

A road test will be conducted with the apparatus fully loaded and a continuous run of no less than ten (10) miles. During that time the apparatus will show no loss of power nor will it overheat. The transmission drive shaft or shafts and the axles will run quietly and be free of abnormal vibration or noise. The apparatus when fully loaded will not have less than 25 percent nor more than 50 percent on the front axle, and not less than 50 percent nor more than 75 percent on the rear axle. The apparatus will meet NFPA 1901 acceleration and braking requirements.

SERVICE AND WARRANTY SUPPORT

Pierce dealership support will be provided by Front Range Fire Apparatus by operating a Pierce authorized service center. The service center will have factory-trained mechanics on staff versed in Pierce fire apparatus. The service facility will be located within fifty (50) miles of the fire department.

In addition to the dealership, Pierce has service facilities located in both, Weyauwega, Wisconsin and Bradenton, Florida. Pierce also maintains a dedicated parts facility of over 100,000 square feet in Appleton, Wisconsin. The parts facility stocks in excess of \$5,000,000 in parts dedicated to service and replacement parts. The parts facility employs a staff dedicated solely for the distribution and shipment of service and replacement parts.

Service parts for the apparatus being proposed can be found via Pierceparts.com which, is an interactive online tool that delivers information regarding your specific apparatus as well as the opportunity to register for training classes.

As a Pierce customer you have the ability to view the complete bill of materials for your specific apparatus, including assembly drawings, piece part drawings, and beneficial parts notations. You will also have the ability to search the complete Pierce item master through a parts search function which offers all Pierce SKU's and descriptions offered on all Pierce apparatus. Published component catalogs, which include proprietary systems along with an extensive operators manual library is available for easy reference.

Pierce Manufacturing maintains a dedicated service and warranty staff of over 35 personnel, dedicated to customer support, which also maintains a 24 hour 7 day a week toll free hot line, four (4) on staff EVTs, and offers hands-on repair and maintenance training classes multiple times a year.

LIABILITY

The successful bidder will defend any and all suits and assume all liability for the use of any patented process including any device or article forming a part of the apparatus or any appliance furnished under the contract.

INSURANCE PROVIDED BY BIDDER

COMMERCIAL GENERAL LIABILITY INSURANCE

The successful bidder will, during the performance of the contract and for three (3) years following acceptance of the product, keep in force at least the following minimum limits of commercial general liability insurance:

Each Occurrence\$1,000,000

Products/Completed Operations Aggregate\$1,000,000

Personal and Advertising Injury\$1,000,000

General Aggregate\$2,000,000

Coverage will be written on a Commercial General Liability form. The policy will be written on an occurrence form and will include Contractual Liability coverage for bodily injury and property damage subject to the terms and conditions of the policy. The policy will include Owner as an additional insured when required by written contract.

COMMERCIAL AUTOMOBILE LIABILITY INSURANCE

The successful bidder will, during the performance of the contract, keep in force at least the following minimum limits of commercial automobile liability insurance and coverage will be written on a Commercial Automobile liability form:

Each Accident Combined Single Limit:\$1,000,000

UMBRELLA/EXCESS LIABILITY INSURANCE

The successful bidder will, during the performance of the contract and for three (3) years following acceptance of the product, keep in force at least the following minimum limits of umbrella liability insurance:

Aggregate:\$3,000,000

Each Occurrence:\$3,000,000

The umbrella policy will be written on an occurrence basis and at a minimum provide excess to the bidder's General Liability and Automobile Liability policies.

The required limits can be provided by one (1) or more policies provided all other insurance requirements are met.

Coverage will be provided by a carrier(s) rated A- or better by A.M. Best.

All policies will provide a 30-day notice of cancellation to the named insured. The Certificate of Insurance will provide the following cancellation clause: Should any of the above described policies be cancelled before the expiration date thereof, notice will be delivered in accordance with the policy provisions.

Bidder agrees to furnish owner with a current Certificate of Insurance with the coverages listed above along with the bid. The certificate will show the purchaser as certificate holder.

INSURANCE PROVIDED BY MANUFACTURER

PRODUCT LIABILITY INSURANCE

The manufacturer will, during the performance of the contract and for three (3) years following acceptance of the product, keep in force at least the following minimum limits of Product Liability insurance:

Each Occurrence\$1,000,000

Products/Completed Operations Aggregate\$1,000,000

Coverage will be written on a Commercial General Liability form. The policy will be written on an occurrence form. The manufacturer's policy will include the owner as additional insured when required by written contract between the Owner and a Pierce authorized dealer.

UMBRELLA/EXCESS LIABILITY INSURANCE

The manufacturer will, during the performance of the contract and for three (3) years following acceptance of the product, keep in force at least the following minimum limits of umbrella liability insurance:

Each Occurrence:\$25,000,000

Aggregate:\$25,000,000

The umbrella policy will be written on an occurrence basis and provide excess to the manufacturer's General Liability/Products policies.

The required limits can be provided by one (1) or more policies provided all other insurance requirements are met.

Coverage will be provided by a carrier(s) rated A- or better by A.M. Best.

All policies will provide a 30-day notice of cancellation to the named insured. The Certificate of Insurance will provide the following cancellation clause: Should any of the above described policies be cancelled before the expiration date thereof, notice will be delivered in accordance with the policy provisions.

Manufacturer agrees to furnish owner with a current Certificate of Insurance with the coverages listed above along with the bid. The certificate will show the purchaser as the certificate holder.

SINGLE SOURCE MANUFACTURER

Pierce Manufacturing, Inc. provides an integrated approach to the design and manufacture of our products that delivers superior apparatus and a dedicated support team. From our facilities, the chassis, cab weldment, cab, pumphouse (including the sheet metal enclosure, valve controls, piping and operators panel) and body will be entirely designed, tested, and hand assembled to the customer's exact specifications. The electrical system either hardwired or multiplexed, will be both designed and integrated by Pierce Manufacturing. The warranties relative to these major components (excluding component warranties such as engine, transmission, axles, pump, etc.) will be provided by Pierce as a single source manufacturer. Pierce's single source solution adds value by providing a fully engineered product that offers durability, reliability, maintainability, performance, and a high level of quality.

Your apparatus will be manufactured in Bradenton, Florida.

NFPA 2016 STANDARDS

This unit will comply with the NFPA standards effective January 1, 2016, except for fire department directed exceptions. These exceptions will be set forth in the Statement of Exceptions.

Certification of slip resistance of all stepping, standing and walking surfaces will be supplied with delivery of the apparatus.

All horizontal surfaces designated as a standing or walking surface that are greater than 48.00" above the ground must be defined by a 1.00" wide line along its outside perimeter. Perimeter markings and designated access paths to destination points will be identified on the customer approval print and are

shown as approximate. Actual location(s) will be determined based on materials used and actual conditions at final build. Access paths may pass through hose storage areas and opening or removal of covers or restraints may be required. Access paths may require the operation of devices and equipment such as the aerial device or ladder rack.

A plate that is highly visible to the driver while seated will be provided. This plate will show the overall height, length, and gross vehicle weight rating.

The manufacturer will have programs in place for training, proficiency testing and performance for any staff involved with certifications.

An official of the company will designate, in writing, who is qualified to witness and certify test results.

NFPA COMPLIANCY

Apparatus proposed by the bidder will meet the applicable requirements of the National Fire Protection Association (NFPA) as stated in the current edition at time of contract execution. Fire Department's specifications that differ from NFPA specifications will be indicated in the proposal as "non-NFPA."

PUMP TEST

The rated water pump will be tested, approved, and certified by an ISO certified independent third party testing agency at the manufacturer's expense. The test results, along with the pump manufacturer's certification of hydrostatic test, the engine manufacturer's certified brake horsepower curve, and the manufacturer's record of pump construction details will be forwarded to the Fire Department.

GENERATOR TEST

If the unit has a generator, the generator will be tested, approved, and certified by an ISO certified independent third party testing agency at the manufacturer's expense. The test results will be provided to the Fire Department at the time of delivery.

WEEKLY PROGRESS REPORTS

Weekly progress reports will be provided. The weekly reports will including photographs of the apparatus or the major components as they are being constructed. The reports will commence at the beginning of the manufacturing process and will continue until just prior to the final inspection. The reports will show the progress of the apparatus through the course of each week. Special attention will be given to show the unique features and aspects of the apparatus as construction progresses.

APPARATUS MANUFACTURER

Pierce Manufacturing is a subsidiary of Oshkosh Truck Corporation located in Oshkosh, Wisconsin. Oshkosh Truck Corporation is a publicly held company traded on the New York Stock Exchange (NYSE OSK). Oshkosh Truck Corporation is a fully owned and managed Corporation that is 100 percent held in the United States of America.

AFTERMARKET SUPPORT WEBSITE

Pierceparts.com will provide Pierce authorized dealer access to comprehensive information pertaining to the maintenance and service of their customer's apparatus. This tool will provide the Pierce authorized dealer the ability to service and support their customers to the best of their ability with factory support at their fingertips.

Pierceparts.com is also accessible to the end user through the guest login. Limited access is available and vehicle specific parts information accessible by entering a specific VIN number. All end users should see their local authorized Pierce dealer for additional support and service.

The website will consist of the following screens at the dealer level:

My Fleet Screen

The My Fleet screen will provide access to truck detail information on the major components of the vehicle, warranty information, available vehicle photographs, vehicle drawings, sales options, applicable vehicle software downloads, etc.

Parts Screens

The Parts screens will provide parts look-up capability of Pierce Manufacturing sourced items, with the aid of digital photographs, part drawings and assembly drawings. The parts search application will permit the searching of parts by item description or function group (major system category). The parts application will provide the ability to submit electronically a parts order, parts quote, or parts return request directly to Pierce Manufacturing for processing.

Warranty Screen

The Warranty screens will provide dealers the ability to submit electronically warranty claims directly to Pierce Manufacturing for reimbursement.

My Reports Screens

The My Reports screens will provide access to multiple dealer reports to allow the dealership to maintain communication with the customer on the status of orders, claims, and phone contacts.

Technical Support Screens

The Technical Support screens will provide access to all currently published Operation and Maintenance and Service Publications. Access to Pierce Manufacturing Service Bulletins and Work Instructions, containing information on current service topics and recommendations will be provided.

Training

The Training screens will provide access to upcoming training classes offered by Pierce Manufacturing along with interactive electronic learning modules (Operators Guides) covering the operation of major vehicle components will be provided. Access to training manuals used in Pierce Manufacturing training classes will be provided.

About Pierce

Access to customer service articles, corporate news, quarterly newsletters, and key contacts within the Customer Service Department will be provided. The current Customer Service Policy and Procedure Manual, detailing the operation of the Customer Service group will also be accessible.

BID BOND NOT REQUESTED

A bid bond will not be included. If requested, the following will apply:

All bidders will provide a bid bond as security for the bid in the form of a 5% bid bond to accompany their bid. This bid bond will be issued by a Surety Company who is listed on the U.S. Treasury Departments list of acceptable sureties as published in Department Circular 570. The bid bond will be issued by an authorized representative of the Surety Company and will be accompanied by a certified power of attorney dated on or before the date of bid. The bid bond will include language, which assures that the bidder/principal will give a bond or bonds as may be specified in the bidding or contract documents, with good and sufficient surety for the faithful performance of the contract, including the Basic One (1) Year Limited Warranty, and for the prompt payment of labor and material furnished in the prosecution of the contract.

Notwithstanding any document or assertion to the contrary, any surety bond related to the sale of a vehicle will apply only to the Basic One (1) Year Limited Warranty for such vehicle. Any surety bond related to the sale of a vehicle will not apply to any other warranties that are included within this bid (OEM or otherwise) or to the warranties (if any) of any third party of any part, component, attachment or accessory that is incorporated into or attached to the vehicle. In the event of any contradiction or inconsistency between this provision and any other document or assertion, this provision will prevail.

PERFORMANCE BOND, 1 YEAR

The successful bidder will furnish a Performance and Payment bond (Bond) equal to 100 percent of the total contract amount within 30 days of the notice of award. Such Bond will be in a form acceptable to the Owner and issued by a surety company included within the Department of Treasury's Listing of Approved Sureties (Department Circular 570) with a minimum A.M. Best Financial Strength Rating of A and Size Category of XV. In the event of a bond issued by a surety of a lesser Size Category, a minimum Financial Strength rating of A+ is required.

Bidder and Bidder's surety agree that the Bond issued hereunder, whether expressly stated or not, also includes the surety's guarantee of the vehicle manufacturer's Basic One (1) Year Limited Warranty period included within this proposal. Owner agrees that the penal amount of this bond will be simultaneously amended to 25 percent of the total contract amount upon satisfactory acceptance and delivery of the vehicle(s) included herein. Notwithstanding anything contained within this contract to the contrary, the surety's liability for any warranties of any type will not exceed one (1) year from the date of such satisfactory acceptance and delivery, or the actual Basic One (1) Year Limited Warranty period, whichever is shorter.

Due to global supply chain constraints, any delivery date contained herein is a good faith estimate as of the date of this order/contract, and merely an approximation based on current information. Delivery updates will be made available, and a final firm delivery date will be provided as soon as possible.

APPROVAL DRAWING

A drawing of the proposed apparatus will be prepared and provided to the purchaser for approval before construction begins. The Pierce sales representative will also be provided with a copy of the same drawing. The finalized and approved drawing will become part of the contract documents. This

drawing will indicate the chassis make and model, location of the lights, siren, horns, compartments, major components, etc.

A "revised" approval drawing of the apparatus will be prepared and submitted by Pierce to the purchaser showing any changes made to the approval drawing.

ELECTRICAL WIRING DIAGRAMS

Two (2) electrical wiring diagrams, prepared for the model of chassis and body, will be provided.

SABER FR CHASSIS

The Pierce Saber FR® is the custom chassis developed exclusively for the fire service. Chassis provided will be a new, tilt-type custom fire apparatus. The chassis will be manufactured in the apparatus body builder's facility eliminating any split responsibility. The chassis will be designed and manufactured for heavy-duty service, with adequate strength, capacity for the intended load to be sustained, and the type of service required. The chassis will be the manufacturer's first line tilt cab.

WHEELBASE

The wheelbase of the vehicle will be 177.5".

GVW RATING

The gross vehicle weight rating will be 43,450 lbs.

FRAME

The chassis frame will be built with two (2) steel channels bolted to five (5) cross members or more, depending on other options of the apparatus.

The frame will be stepped down behind the cab for a lower center of gravity and increased vehicle stability.

The side rails will be heat-treated steel measuring 10.25" x 3.50" x 0.375".

Each side rail will have a section modulus of 15.75 cubic inches, and a resisting bending moment (rbm) of 1,942,000 inch-pounds with a total resisting bending moment (rbm) of 3,884,000 inch-pounds.

FRONT AXLE

The front axle will be a Marmon Herrington axle, Model MT-22, with a rated capacity of 19,450 lb.

It will be a planetary hub reduction type, steer able axle.

FRONT SUSPENSION

The front springs will be a Standens, three (3)-leaf, taper leaf design, 54.00" long x 4.00" wide, with a ground rating of 20,000 lb.

The two (2) top leaves will wrap the forward spring hanger pin. The top leaf will also wrap the rear spring hanger pin. Both the front and rear eyes will be Berlin style wraps that will place the eyes in the horizontal plane within the main leaf. This will reduce bending stress from acceleration and braking.

A steel encased rubber bushing will be used in the spring eye. The steel encased rubber bushing will be maintenance free and require no lubrication.

SHOCK ABSORBERS

To provide a smoother ride, the front axle will be furnished with heavy-duty telescoping shock absorbers.

GREASE SEALS

Grease seals will be provided on the front axle. Stamped steel hub covers will be provided.

DRIVER CONTROL DIFFERENTIAL LOCK (DCDL)

The front axle will be equipped with a driver controlled differential lock (DCDL).

The control will be located within easy reach of the driver. An indicator light will be provided next to the control switch.

FRONT TIRES

The front tires will be Michelin 315/80R22.5 radials, 20 ply all position XZU® S2 tread, rated for 20,000 lb maximum axle load and 65 mph maximum speed.

The tires will be mounted on Accuride® 22.50" x 9.00" steel disc type wheels with a ten (10) stud, 11.25" bolt circle.

REAR AXLE

The rear axle will be an Eaton, Model 230S4, power divider type with a capacity of 24,000 lb. The main input pinion will be geared through a drive train, to a second output pinion, on the forward face of the rear axle carrier. This in turn, will be connected to the front driving axle through a multi-piece drive shaft with a permanent section utilizing two (2) midship bearings at the approximate midpoint of the vehicle.

Actuation of the front wheel drive will be a driver controlled air operated clutch pack in the rear axle permitting engagement or disengagement of the front axle. There will be an indicator light on the cab instrument panel to show when the front axle is engaged. Shift control for front axle will have a guard so the front axle cannot be accidentally engaged.

TOP SPEED OF VEHICLE

A rear axle ratio will be furnished to allow the vehicle to reach a top speed of 63 MPH.

REAR SUSPENSION

The rear suspension will be Standens, semi-elliptical, 3.00" wide x 53.00" long, 12-leaf pack with a ground rating of 24,000 lb. The spring hangers will be castings.

The two (2) top leaves will wrap the forward spring hanger pin, and the rear of the spring will be a slipper style end that will ride in a rear slipper hanger. To reduce bending stress due to acceleration and braking, the front eye will be a berlin eye that will place the front spring pin in the horizontal plane within the main leaf.

A steel encased rubber bushing will be used in the spring eye. The steel encased rubber bushing will be maintenance free and require no lubrication.

REAR OIL SEALS

Oil seals will be provided on the rear axle(s).

DRIVER CONTROL DIFFERENTIAL LOCK (CTD)

The rear axle will be equipped with a driver controlled differential lock (CTD). The control will be located within easy reach of the driver.

REAR TIRES

Rear tires will be four (4) Michelin 12R22.50 radials, 16 ply all season XDN2 tread, rated for 27,120 lb maximum axle load and 75 mph maximum speed.

The tires will be mounted on Accuride® 22.50" x 9.00" steel disc type wheels with a ten (10) stud, 11.25" bolt circle.

TIRE BALANCE

All tires will be balanced with Counteract balancing beads. The beads will be inserted into the tire and eliminate the need for wheel weights.

TIRE PRESSURE MANAGEMENT

There will be a RealWheels® LED AirSecure tire alert pressure management system provided, that will monitor each tire's pressure. A sensor will be provided on the valve stem of each tire for a total of two (2) tires.

The sensor will calibrate to the tire pressure when installed on the valve stem for pressures between 10 and 200 psi. The sensor will activate an integral battery operated LED when the pressure of that tire drops five (5) to eight (8) psi.

Removing the cap from the sensor will indicate the functionality of the sensor and battery. If the sensor and battery are in working condition, the LED will immediately start to flash.

CHROME LUG NUT COVERS

Chrome lug nut covers will be supplied on front and rear wheels.

MUD FLAPS

Mud flaps with a Pierce logo will be installed behind the front and rear wheels.

AIR PRESSURE TIRE EQUALIZATION

A Crossfire air pressure equalization system will be provided on the rear dual wheels. This system will equalize the tire air pressure in the rear duals and indicate over or under inflation.

WHEEL CHOCKS

There will be one (1) pair of folding Ziamatic, Model SAC-44-E, aluminum alloy, Quick-Choc wheel blocks, with easy-grip handle provided.

Wheel Chock Brackets

There will be one (1) pair of Zico, Model SQCH-44-H, horizontal mounting wheel chock brackets provided for the Ziamatic, Model SAC-44-E, folding wheel chocks. The brackets will be made of

aluminum and consist of a quick release spring loaded rod to hold the wheel chocks in place. The brackets will be mounted forward of the left side rear tire.

ANTI-LOCK BRAKE SYSTEM

The vehicle will be equipped with a Wabco 4S4M, anti-lock braking system. The ABS will provide a four (4) channel anti-lock braking control on both the front and rear wheels. A digitally controlled system that utilizes microprocessor technology will control the anti-lock braking system. Each wheel will be monitored by the system. When any wheel begins to lockup, a signal will be sent to the control unit. This control unit will then reduce the braking of that wheel for a fraction of a second and then reapply the brake. This anti-lock brake system will eliminate the lockup of any wheel thus helping to prevent the apparatus from skidding out of control.

ELECTRONIC STABILITY CONTROL

A vehicle control system will be provided as an integral part of the ABS brake system from Meritor Wabco, operational only when the vehicle is in 4x2 mode.

The system will monitor and update the lateral acceleration (cornering) of the vehicle and compare it to a critical threshold where a side roll event may occur. If the critical threshold is met, the vehicle control system will automatically reduce engine RPM, engage the engine retarder (if equipped), and selectively apply brakes to the individual wheel ends of the front and rear axles to reduce the possibility of a side roll event.

The system will monitor directional stability through an electronic lateral accelerometer, steer angle sensor and yaw rate sensor. If spinout or drift out is detected, the vehicle control system will selectively apply brakes to the individual wheel ends of the front and rear axles to assist in bringing the vehicle back to its intended direction. The operator will continue to provide steering input in the desired direction as the system compensates.

Electronic Stability Control is not a guarantee that a side roll event, spin out or drift out will not occur. ESC is a supplemental safety system that will be used in conjunction with safe driving habits.

AUTOMATIC TRACTION CONTROL

An anti-slip feature will be included with the ABS operational only when the vehicle is in 4x2 mode. The Automatic Traction Control will be used for traction in poor road and weather conditions. The Automatic Traction Control will act as an electronic differential lock that will not allow a driving wheel to spin, thereby supplying traction at all times. The ABS electronic control unit (ECU) will work with the engine ECU, sharing information concerning wheel slip. Engine ECU will use information to control engine speed, allowing only as much throttle application as required for the available traction, regardless of how much the driver is asking for.

BRAKES

The service brake system will be full air type by Bendix®.

Front brakes will be Model ADB22X™, disc type with automatic pad wear adjustment and 17.00" rotors for improved stopping distance.

The rear brakes will be Bendix®, Model ES1657D, 16.50" x 7.00" cam operated with automatic slack adjusters.

BRAKE SYSTEM AIR COMPRESSOR

The air compressor will be a Cummins/WABCO with 18.7 cubic feet per minute output.

BRAKE SYSTEM

The brake system will include:

- Brake treadle valve
- Heated automatic moisture ejector on air dryer
- Total air system minimum capacity of 5,376 cubic inches
- Two (2) air pressure gauges with a red warning light and an audible alarm, that activates when air pressure falls below 60 psi
- Spring set parking brake system
- Parking brake operated by a push-pull style control valve
- A parking "brake on" indicator light on instrument panel
- Park brake relay/inversion and anti-compounding valve, in conjunction with a double check valve system, with an automatic spring brake application at 40 psi
- A pressure protection valve to prevent all air operated accessories from drawing air from the air system when the system pressure drops below 80 psi (550 kPa)
- 1/4 turn drain valves on each air tank

The air tank will be primed and painted to meet a minimum 750 hour salt spray test.

To reduce the effects of corrosion, the air tank will be mounted with stainless steel brackets.

BRAKE SYSTEM AIR DRYER

The air dryer will be a WABCO System Saver 1200 IWT, with internal wet tank, spin-on coalescing filter cartridge and 100 watt heater.

BRAKE LINES

Color-coded nylon brake lines will be provided per SAE J2580.

- Supply -Black
- Primary - Green
- Secondary - Orange
- Park - Red

The lines will be wrapped in a heat protective loom where necessary in the chassis.

AIR INLET WITH AUTOMATIC EJECT

One (1) air inlet with Kussmaul Air Eject will be provided. It will allow station air to be supplied to the apparatus brake system through a shoreline hose. The inlet will automatically disconnect the air line when the truck is started. It will be equipped with a male coupling and be located driver side step well (see drawing). A check valve will be provided to prevent reverse flow of air. The inlet will discharge

into the "wet" tank of the brake system. A mating female coupling will also be provided with the loose equipment.

ADDITIONAL AIR TANK

An additional air tank with 1454 cubic inch displacement will be provided to increase the capacity of the main air brake system. This tank will be plumbed into the rear half of the brake system.

The air tank will be primed and painted to meet a minimum 750 hour spray test. To reduce the effects of corrosion, the air tank will be mounted with stainless steel brackets.

The output flow of the engine air compressor will vary with engine rpm. Full compressor output will only be achieved at governed engine speed. Engine speed will be limited by generators, pumps and other PTO driven options.

AUTOMATIC MOISTURE EJECTORS

Bendix, Model DV-2, moisture ejectors for a single axle pumper reservoir capacity will be installed in the brake system.

Each moisture ejector will be equipped with a 12-volt heater, controlled by thermostat and ignition switch.

The moisture ejectors will be provided on all reservoirs.

ENGINE

The chassis will be powered by an electronically controlled engine as described below:

Make:	Cummins
Model:	L9
Power:	450 hp at 2100 rpm
Torque:	1250 lb-ft at 1400 rpm
Governed Speed:	2200 rpm
Emissions Level:	EPA 2024
Fuel:	Diesel
Cylinders:	Six (6)
Displacement:	543 cubic inches (8.9L)
Starter:	Delco 39MT™
Fuel Filters:	Spin-on style primary filter with water separator and water-in-fuel sensor. Secondary spin-on style filter.

The engine will include On-board diagnostics (OBD), which provides self diagnostic and reporting. The system will give the owner or repair technician access to state of health information for various vehicle sub systems. The system will monitor vehicle systems, engine and after treatment. The system will illuminate a malfunction indicator light on the dash console if a problem is detected.

HIGH IDLE

A high idle switch will be provided, inside the cab, on the instrument panel, that will automatically maintain a preset engine rpm. A switch will be installed, at the cab instrument panel, for activation/deactivation.

The high idle will be operational only when the parking brake is on and the truck transmission is in neutral. A green indicator light will be provided, adjacent to the switch. The light will illuminate when the above conditions are met. The light will be labeled "OK to Engage High Idle."

ENGINE BRAKE

A Jacobs® engine brake is to be installed with the controls located on the instrument panel within easy reach of the driver.

The driver will be able to turn the engine brake system on/off and have a high, medium and low setting.

The engine brake will activate when the system is on and the throttle is released.

The high setting of the brake application will activate and work simultaneously with the variable geometry turbo (VGT) provided on the engine.

The engine brake will be installed in such a manner that when the engine brake is slowing the vehicle the brake lights are activated.

The ABS system will automatically disengage the auxiliary braking device, when required.

CLUTCH FAN

A fan clutch will be provided. The fan clutch will be automatic when the pump transmission is in "Road" position, and constantly engaged when in "Pump" position.

ENGINE AIR INTAKE

The engine air intake will be located above the engine cooling package. It will draw fresh air from the front of the apparatus through the radiator grille.

The ember separator is designed to prevent road dirt and recirculating hot air from entering the engine.

The ember separator will be easily accessible by tilting the cab.

EXHAUST SYSTEM

The exhaust system will be stainless steel from the turbo to the engine's aftertreatment device, and will be 4.00" in diameter. The exhaust system will include a single module aftertreatment device to meet current EPA standards. An insulation wrap will be provided on all exhaust pipes between the turbo and aftertreatment device to minimize the heat loss to the aftertreatment device. The exhaust will terminate horizontally ahead of the right side rear wheels. A tailpipe diffuser will be provided to reduce the temperature of the exhaust as it exits. Heat deflector shields will be provided to isolate chassis and body components from the heat of the tailpipe diffuser.

RADIATOR

The radiator and the complete cooling system will meet or exceed NFPA and engine manufacturer cooling system standards.

For maximum corrosion resistance and cooling performance, the entire radiator core will be constructed using long life aluminum alloy. The radiator core will consist of aluminum fins, having a serpentine design, brazed to aluminum tubes.

The radiator core will have a minimum front area of 1060 square inches.

Supply tank will be made of heavy duty glass-reinforced nylon and the return tank will be made of aluminum. Both tanks will be crimped onto the core assembly using header tabs and a compression gasket to complete the radiator core assembly. There will be a full steel frame around the inserts to enhance cooling system durability and reliability.

The radiator will be compatible with commercial antifreeze solutions.

The radiator assembly will be isolated from the chassis frame rails with rubber isolators to prevent the development of leaks caused by twisting or straining when the apparatus operates over uneven terrain.

The radiator will include a de-aeration/expansion tank. For visual coolant level inspection, the radiator will have a built-in sight glass. The radiator will be equipped with a 15 psi pressure relief cap.

A drain port will be located at the lowest point of the cooling system and/or the bottom of the radiator to permit complete flushing of the coolant from the system.

Shields or baffles will be provided to prevent recirculation of hot air to the inlet side of the radiator.

COOLANT LINES

Gates, or Goodyear, rubber hose will be used for all engine coolant lines installed by Pierce Manufacturing.

Hose clamps will be stainless steel constant torque type to prevent coolant leakage. They will expand and contract according to coolant system temperature thereby keeping a constant clamping pressure on the hose.

FUEL TANK

A 75 gallon fuel tank will be provided and mounted at the rear of the chassis. The tank will be constructed of 12-gauge, hot rolled steel. It will be equipped with swash partitions and a vent. To eliminate the effects of corrosion, the fuel tank will be mounted with stainless steel straps.

A .75" drain plug will be located in a low point of the tank for drainage.

A fill inlet will be located on the left hand side of the body and is covered with a hinged, spring loaded, stainless steel door that is marked "Ultra Low Sulfur - Diesel Fuel Only." The fuel door will be brushed stainless steel

A .50" diameter vent will be installed from tank top to just below fuel fill inlet.

The fuel tank will meet all FHWA 393.67 requirements including a fill capacity of 95 percent of tank volume.

All fuel lines will be provided as recommended by the engine manufacturer.

DIESEL EXHAUST FLUID TANK

A 4.5 gallon diesel exhaust fluid (DEF) tank will be provided and mounted in the driver's side body forward of the rear axle.

A 0.50" drain plug will be provided in a low point of the tank for drainage.

A fill inlet will be provided and marked "Diesel Exhaust Fluid Only". The fill inlet will be located below the air bottle storage behind a common door on the driver side of the vehicle.

The tank will meet the engine manufacturers requirement for 10 percent expansion space in the event of tank freezing.

The tank will include an integrated heater unit that utilizes engine coolant to thaw the DEF in the event of freezing.

FUEL PRIMING PUMP

A Cummins automatic electronic fuel priming pump will be integrated as part of the engine.

TRANSMISSION

An Allison 6th generation, Model EVS 3000P, electronic torque converting automatic transmission will be provided.

The transmission will be equipped with prognostics to monitor oil life, filter life, and transmission health. A wrench icon on the shift selector's digital display will indicate when service is due.

Two (2) PTO openings will be located on both sides of converter housing (positions 4 o'clock and 8 o'clock) as viewed from the rear.

A transmission temperature gauge with amber light and audible alarm will be installed on the cab dash.

TRANSMISSION SHIFTER

A five (5)-speed push button shift module will be mounted to right of driver on console. Shift position indicator will be indirectly lit for after dark operation.

The transmission ratio will be:

1st	3.49 to 1.00
2nd	1.86 to 1.00
3rd	1.41 to 1.00
4th	1.00 to 1.00
5th	0.75 to 1.00
R	5.03 to 1.00

TRANSMISSION COOLER

A Modine plate and fin transmission oil cooler will be provided using engine coolant to control the transmission oil temperature.

DOWNSHIFT MODE (W/ENGINE BRAKE)

The transmission will be provided with an aggressive downshift mode.

This will provided earlier transmission downshifts to 2nd gear, resulting in improved engine braking performance.

DRIVELINE

Drivelines will be a heavy-duty metal tube and be equipped with Spicer® 1710 universal joints.

The shafts will be dynamically balanced before installation.

A splined slip joint will be provided in each driveshaft where the driveline design requires it. The slip joint will be coated with Glidecoat® or equivalent.

STEERING

Dual steering gear, with integral heavy-duty power steering, will be provided. For reduced system temperatures, the power steering will incorporate an air to oil cooler and Vickers® V20NF hydraulic pump with integral pressure and flow control. All power steering lines will have wire braded lines with crimped fittings.

A tilt and telescopic steering column will be provided to improve fit for a broader range of driver configurations.

STEERING WHEEL

The steering wheel will be 18.00" in diameter, have tilting and telescoping capabilities, and a 4-spoke design.

LOGO AND CUSTOMER DESIGNATION ON DASH

The dash panel will have an emblem containing the Pierce logo and customer name. The emblem will have three (3) rows of text for the customer's department name. There will be a maximum of eight (8) characters in the first row, 11 characters in the second row and 11 characters in the third row.

The first row of text will be: Nederland

The second row of text will be: Fire

The third row of text will be: District

FRONT WINCH

A Superwinch Tiger Shark series, Model 1518001, an 18,000 pound electric winch will nest below the top aluminum treadplate surface of the front bumper. A cover for maintenance and access to the winch direction control lever and remote control plug will be provided. The cover will be provided with a pneumatic stay arm hold-open device.

Winch will be mounted on a surface that will not flex when the winch is in use, since it could bind working parts of the winch.

Winch will be braced as recommended by the winch manufacturer.

The winch will include 90 feet of .50" synthetic rope, with hook pre-spooled on the drum.

Winch will have a 2-stage planetary gearing.

Wire cables to battery will be two (2)-gauge or larger. Speed and amperage draw of winch will be variable depending on winch load.

Winch will have a minimum of a 15' remote control cable.

A Hawse style fairlead will be supplied of sufficient strength to accommodate the winch capacity.

A label will be placed on or near the mount that states the maximum winch load rating and the maximum rope load rating that the mount can support.

BUMPER

A one (1) piece bumper manufactured from .38" formed A36 steel with a .38" bend radius will be provided. The bumper will be a minimum of 10.88" high with a 1.50" top and bottom flange, and will extend 16.00" from the face of the cab. The bumper will be 95.28" wide with 45 degree corners and side plates. The bumper will be metal finished and painted job color.

To provide adequate support strength, the bumper will be mounted directly to the front of the C channel frame. The frame will be a bolted modular extension frame constructed of 50,000 psi tensile steel.

GRAVEL PAN

A gravel pan, constructed of bright aluminum treadplate, will be furnished between the bumper and the cab face. The pan will be properly supported from the underside to prevent flexing and vibration.

TOW EYES

Two (2) tow eyes will be mounted through the front face of the bumper.

The inner and outer edges of the tow eyes will have a .25" radius.

The tow eyes will be mounted directly to the bumper frame.

Cutouts will be provided in the front face of the stainless steel bumper to allow the tow eyes to extend out the front.

The tow eyes will be designed and positioned to allow up to a 9,000 lb straight horizontal pull in line with the centerline of the vehicle. The tow eyes will not be used for lifting of the apparatus.

The tow eyes will be painted black.

CAB

The Saber FR cab will be designed specifically for the fire service and manufactured by the chassis builder.

The cab will be built by the apparatus manufacturer in a facility located on the manufacturer's premises.

For reasons of structural integrity and enhanced occupant protection, the cab will be a heavy duty design, constructed to the following minimal standards.

The cab will have 12 main vertical structural members located in the A-pillar (front cab corner posts), B-pillar (side center posts), C-pillar (rear corner posts), and rear wall areas. The A-pillar will be constructed of solid A356-T5 aluminum castings. The B-pillar and C-pillar will be constructed from 0.13" wall extrusions. The rear wall will be constructed of two (2) 2.00" x 2.00" outer aluminum extrusions and two (2) 2.00" x 1.00" inner aluminum extrusions. All main vertical structural members will run from the floor to 4.625" x 3.864" x 0.090" thick roof extrusions to provide a cage-like structure with the A-pillar and roof extrusions being welded into a 0.25" thick corner casting at each of the front corners of the roof assembly.

The front of the cab will be constructed of a 0.13" firewall plate, covered with a 0.090" front skin (for a total thickness of 0.22"), and reinforced with a full width x 0.50" thick cross-cab support located just below the windshield and fully welded to the engine tunnel. The cross-cab support will run the full width of the cab and weld to each A-pillar, the 0.13" firewall plate, and the front skin.

The cab floors will be constructed of 0.125" thick aluminum plate and reinforced at the firewall with an additional 0.25" thick cross-floor support providing a total thickness of 0.375" of structural material at the front floor area. The front floor area will also be supported with two (2) triangular 0.30" wall extrusions that also provides the mounting point for the cab lift. This tubing will run from the floor wireway of the cab to the engine tunnel side plates, creating the structure to support the forces created when lifting the cab.



The cab will be 96.00" wide (outside door skin to outside door skin) to maintain maximum maneuverability.

The cab will have an overall height (from the cab roof to the ground) of approximately 99.00". The overall height listed will be calculated based on a truck configuration with the lowest suspension weight rating, the smallest diameter tires for the suspension, no water weight, no loose equipment weight, and no personnel weight. Larger tires, wheels, and suspension will increase the overall height listed.

The floor to ceiling height inside the crew cab will be 54.50" in the center and outboard positions.

The crew cab floor will measure 36.00" from the rear wall to the front of the rear facing seat risers.

The engine tunnel, at the rearward highest point (knee level), will measure 51.50" to the rear wall.

The crew cab will be a totally enclosed design with the interior area completely open to improve visibility and verbal communication between the occupants.

The cab will be a full tilt cab style.

A 3-point cab mount system with rubber isolators will improve ride quality by isolating chassis vibrations from the cab.

CAB ROOF DRIP RAIL

For enhanced protection from inclement weather, a drip rail will be furnished on the sides of the cab. The drip rail will be painted to match the cab roof, and bonded to the sides of the cab. The drip rail will extend the full length of the cab roof.

INTERIOR CAB INSULATION

The cab will include 1.00" insulation in the ceiling, 1.50" insulation in the side walls, and 2.00" insulation in the rear wall to maximize acoustic absorption and thermal insulation.

FENDER LINERS

Full circular inner fender liners in the wheel wells will be provided.

PANORAMIC WINDSHIELD

A one (1)-piece safety glass windshield will be provided with over 2,775 square inches of clear viewing area. The windshield will be full width and will provide the occupants with a panoramic view. The windshield will consist of three (3) layers: outer light, middle safety laminate, and inner light. The outer light layer will provide superior chip resistance. The middle safety laminate layer will prevent the windshield glass pieces from detaching in the event of breakage. The inner light will provide yet another chip resistant layer. The cab windshield will be bonded to the aluminum windshield frame using a urethane adhesive. A custom frit pattern will be applied on the outside perimeter of the windshield for a finished automotive appearance.



WINDSHIELD WIPERS

Three (3) electric windshield wipers with washer will be provided that meet FMVSS and SAE requirements.

The washer reservoir will be able to be filled without raising the cab.

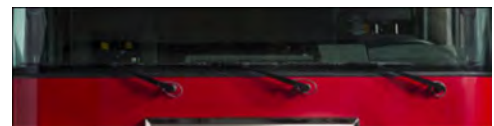

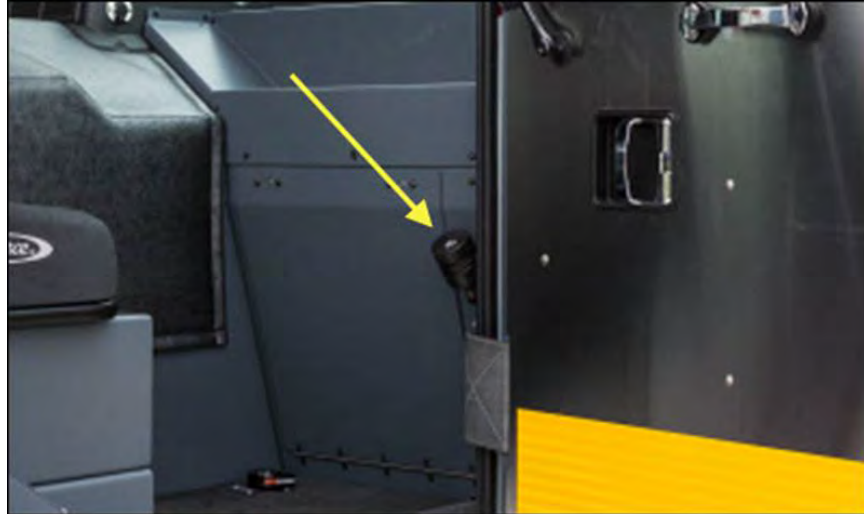

[Washer Reservoir Location]

ENGINE TUNNEL

Engine hood side walls will be constructed of 0.375" aluminum. The top will be constructed of 0.125" aluminum and will be tapered at the top to allow for more driver and passenger elbow room.

The engine hood will be insulated for protection from heat and sound. The noise insulation keeps the dBA level within the limits stated in the current NFPA 1901 standards.

The engine tunnel will be no higher than 17.00" off the crew cab floor.

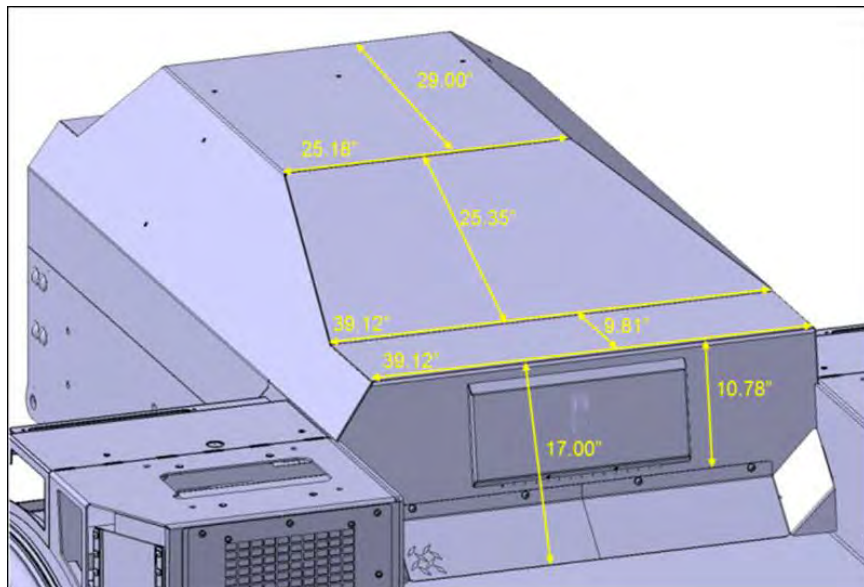

INTERIOR CREW CAB REAR WALL ADJUSTABLE SEATING (PATENT PENDING)

The interior rear wall of the crew cab will have mounting holes every 2.75" to allow for adjustability of the forward facing crew cab seating along the rear wall. Seats will be adjustable with use of simple hand tools allowing departments flexibility of their seating arrangement should their department needs change.



CAB REAR WALL EXTERIOR COVERING

The exterior surface of the rear wall of the cab will be painted job color.

CAB LIFT

A hydraulic cab lift system will be provided consisting of an electric powered hydraulic pump, dual lift cylinders, and necessary hoses and valves.

Lift controls will be located on the right side pump panel or front area of the body in a convenient location.

The cab will be capable of tilting 43 degrees to accommodate engine maintenance and removal.

The cab will be locked down by a 2-point normally closed spring loaded hook type latch that fully engages after the cab has been lowered. The system will be hydraulically actuated to release the normally closed locks when the cab lift control is in the raised position and cab lift system is under pressure. When the cab is completely lowered and system pressure has been relieved, the spring loaded latch mechanisms will return to the normally closed and locked position.



The hydraulic cylinders will be equipped with a velocity fuse that protects the cab from accidentally descending when the control is located in the tilt position.

For increased safety, a redundant mechanical stay arm will be provided that must be manually put in place on the left side between the chassis and cab frame when the cab is in the raised position. This device will be manually stowed to its original position before the cab can be lowered.

Cab Lift Interlock

The cab lift system will be interlocked to the parking brake. The cab tilt mechanism will be active only when the parking brake is set and the ignition switch is in the on position. If the parking brake is released, the cab tilt mechanism will be disabled.

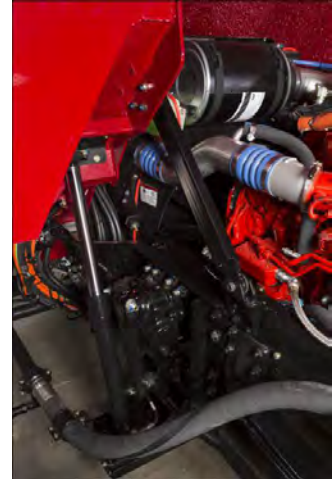

GRILLE

A single piece polished stainless steel grille and framework will be provided on the front center of the cab.

MIRRORS

A Retrac, Model 613423, dual vision, motorized, west coast style mirror, with chrome finish, will be mounted on each side of the front cab door with spring loaded retractable arms. The flat glass and convex glass will be heated and adjustable with remote control within reach of the driver.

DOORS

To enhance entry and egress to the cab, the forward cab door openings will be a minimum of 37.50" wide x 63.37" high. The crew cab doors will be located on the sides of the cab and will be constructed in the same manner as the forward cab doors. The crew cab door openings will be a minimum of 34.30" wide x 63.37" high.

The forward cab and crew cab doors will be constructed of extruded aluminum with a nominal material thickness of 0.093". The exterior door skins will be constructed from 0.090" aluminum.

A customized, vertical, pull-down type door handle will be provided on the exterior of each cab door. The finish of the door handle will be chrome/black. The exterior handle will be designed specifically for the fire service to prevent accidental activation, and will provide 4.00" wide x 2.00" deep hand clearance for ease of use with heavy gloved hands.



[Exterior Door Handle]

Each door will also be provided with an interior flush, open style paddle handle that will be readily operable from fore and aft positions, and be designed to prevent accidental activation. The interior handles will provide 4.00" wide x 1.25" deep hand clearance for ease of use with heavy gloved hands.

The cab doors will be provided with both interior (rotary knob) and exterior (keyed) locks exceeding FMVSS standards. The keys will be Model 751. The locks will be capable of activating when the doors are open or closed. The doors will remain locked if locks are activated when the doors are opened, then closed.



[Interior Door Handle]

A full length, heavy duty, stainless steel, piano-type hinge with a 0.38" pin and 11 gauge leaf will be provided on all cab doors. There will be double automotive-type rubber seals around the perimeter of the door framing and door edges to ensure a weather-tight fit.

A chrome handle will be provided on the inside of each cab door for ease of entry.

A red webbed grab handle will be installed on the crew cab door stop strap. The grab handles will be securely mounted.

The bottom cab step at each cab door location will be located below the cab doors and will be exposed to the exterior of the cab.

Door Panels

The inner cab door panels will be constructed out of brushed stainless steel.

MANUAL CAB DOOR WINDOWS

All cab entry doors will contain a conventional roll down window.

CAB STEPS

The forward cab and crew cab access steps will be a full size two (2) step design to provide largest possible stepping surfaces for safe ingress and egress. The bottom steps will be designed with a grip pattern punched into bright aluminum treadplate material to provide support, slip resistance, and drainage. The bottom steps will be a bolt-in design to minimize repair costs should they need to be replaced. The forward cab steps will be a minimum 25.00" wide, and the crew cab steps will be 21.65" wide with an 8.00" minimum depth. The inside cab steps will not exceed 16.50" in height.

The vertical surfaces of the step well will be aluminum treadplate.

CAB EXTERIOR HANDRAILS

A 1.25" diameter slip-resistant, knurled aluminum handrail will be provided adjacent to each cab and crew cab door opening to assist during cab ingress and egress.

The handrails at each front cab door will be 21.00" long. The handrails at each crew cab door will be 32.00" long.

STIRRUP STEPS

Hinged, swing style stirrup steps will be provided below each cab and crew cab door.

The stirrup step will be lit by a white 12 volt DC LED light provided on the step.

The step light will be activated automatically when the battery switch is on and the exit doors are opened or by the same means as the body step lights.

STEP LIGHTS

There will be six (6) white LED step lights with chrome housing installed for cab and crew cab access steps.

- One (1) light for the left access steps.
- Two (2) lights for the left side crew cab access steps.
- Two (2) lights for the right side crew cab access steps.
- One (1) light for the right side access step.

In order to ensure exceptional illumination, each light will provide a minimum of 25 foot-candles (fc) covering an entire 15" x 15" square placed ten (10) inches below the light and a minimum of 1.5 fc covering an entire 30" x 30" square at the same ten (10) inch distance below the light.

The lights will be activated when the battery switch is on and the adjacent door is opened.

FENDER CROWNS

Rubber fender crowns will be provided around the cab wheel openings.

Crowns will be black.

CREW CAB WINDOWS

One (1) fixed window with tinted glass will be provided on each side of the cab, to the rear of the front cab door. The windows will be sized to enhance light penetration into the cab interior. The windows will measure 18.70" wide x 23.75" high.



CUP HOLDER

There will be four (4) cup holder(s) provided. Each cup holder will be 4.00" in diameter x 4.00" high. An approximate 1.00" wide recess in the cup holder will allow it to hold beverage containers with handles.

Black rubber matting will be provided on the bottom of each cup holder.

The cup holder(s) will be painted to match the cab interior and located To be mounted at final inspection.

CAB DASH

The driver side dash, switch panel located to the right of the driver, and center console will be an easily removable high impact resistant polymer cover.

The instrument gauge cluster will be surrounded with a high impact ABS plastic contoured to the same shape of the instrument gauge cluster.

The officer side dash will be a flat top design with an upper beveled edge to provide easy maintenance and will be constructed out of aluminum and painted to match the cab interior.

MOUNTING PLATE ON ENGINE TUNNEL

Equipment installation provisions will be installed on the engine tunnel.

A 0.188" smooth aluminum plate will be bolted to the top surface of the engine tunnel. The plate will follow the contour of the engine tunnel and will run the entire length of the engine tunnel. The plate will be spaced off the engine tunnel .75" to allow for wire routing below the plate.

The mounting surface will be painted to match the cab interior.

MOUNTING PLATE(S)

There will be one (1) driver side interior rear cab wall (full area between cabinet and outer cab wall) 0.188" aluminum mounting plate(s) provided and installed driver side interior rear cab wall (full area between cabinet and outer cab wall). The mounting surface will be painted to match the cab interior. The plates(s) will be mounted on .75" spacer stand-offs.

CAB INTERIOR

The cab interior will be constructed of primarily metal (painted aluminum) to withstand the severe duty cycles of the fire service.

The engine tunnel will be painted aluminum to match the cab interior.

For durability and ease of maintenance, the cab interior side walls will be painted aluminum. The rear wall will be painted aluminum.

The headliner will be installed in both forward and rear cab sections. Headliner material will be vinyl. A sound barrier will be part of its composition. Material will be installed on an aluminum sheet and securely fastened to interior cab ceiling.

The forward portion of the cab headliner will permit easy access for service of electrical wiring or other maintenance needs.

All wiring will be placed in metal raceways.

CAB INTERIOR UPHOLSTERY

The cab interior upholstery will be 36 oz black vinyl.

CAB INTERIOR PAINT

The cab interior metal surfaces, excluding the rear heater panels, will be painted black, vinyl texture paint.

The rear heater panels will be painted black, vinyl textured paint.

CAB FLOOR

The cab and crew cab floor areas will be covered with Polydamp™ acoustical floor mat consisting of a black pyramid rubber facing and closed cell foam decoupler.

The top surface of the material has a series of raised pyramid shapes evenly spaced, which offer a superior grip surface. Additionally, the material has a 0.25" thick closed cell foam (no water absorption) which offers a sound dampening material for reducing sound levels.

DEFROST/AIR CONDITIONING SYSTEM

A ceiling mounted combination heater, defroster and air conditioning system will be installed in the cab above the engine tunnel area.

Cab Defroster

A 54,000 BTU heater-defroster unit with 690 SCFM of air flow will be provided inside the cab. The heater-defrost will be installed in the forward portion of the cab ceiling. Air outlets will be strategically located in the cab header extrusion per the following:

- One (1) adjustable will be directed towards the left side cab window
- One (1) adjustable will be directed towards the right side cab window
- Six (6) fixed outlets will be directed at the windshield

The defroster will be capable of clearing 98 percent of the windshield and side glass when tested under conditions where the cab has been cold soaked at 0 degrees Fahrenheit for 10 hours, and a 2 ounce per square inch layer of frost/ice has been able to build up on the exterior windshield. The defroster system will meet or exceed SAE J382 requirements.

Cab/Crew Auxiliary Heater

There will be one (1) 31,000 BTU auxiliary heater with 560 SCFM of air flow provided in each outboard rear facing seat risers with a dual scroll blower. An aluminum plenum incorporated into the cab structure used to transfer heat to the forward positions.

Air Conditioning

A condenser will be a 59,644 BTU output that meets and exceeds the performance specification will be mounted on the radiator.

The air conditioning system will be capable of cooling the average cab temperature from 100 degrees Fahrenheit to 75 degrees Fahrenheit at 50 percent relative humidity within 30 minutes. The cooling

performance test will be run only after the cab has been heat soaked at 100 degrees Fahrenheit for a minimum of 4 hours.

The evaporator unit will be installed in the rear portion of the cab ceiling over the engine tunnel. The evaporator will include one (1) high performance heating core, one (1) high performance cooling core with (1) plenum directed to the front and one (1) plenum directed to the rear of the cab.

The evaporator unit will have a 52,000 BTU at 690 SCFM rating that meets and exceeds the performance specifications.

Adjustable air outlets will be strategically located on the forward plenum cover per the following:

- Four (4) will be directed towards the seating position on the left side of the cab
- Four (4) will be directed towards the seating position on the right side of the cab

Adjustable air outlets will be strategically located on the evaporator cover per the following:

- Five (5) will be directed towards crew cab area

A high efficiency particulate air (HEPA) filter will be included for the system. Access to the filter cover will be secured with four (4) screws.

The air conditioner refrigerant will be R-134A and will be installed by a certified technician.

Climate Control

An automotive style controller will be provided to control the heat and air conditioning system within the cab. The controller will have three (3) functional knobs for fan speed, temperature, and air flow distribution (front to rear) control.



The system will control the temperature of the cab and crew cab automatically by pushing the center of the fan speed control knob. Rotate the center temperature control knob to set the cab and crew cab temperature.

The AC system will be manually activated by pushing the center of the temperature control knob. Pushing the center of the air flow distribution knob will engage the AC for max defrost, setting the fan speeds to 100 percent and directing all air flow to the overhead forward position.

The system controller will be located within panel position #12.

Gravity Drain Tubes

Two (2) condensate drain tubes will be provided for the air conditioning evaporator. The drip pan will have two (2) drain tubes plumbed separately to allow for the condensate to exit the drip pan. No pumps will be provided.

WINDOW DEFROST FANS

Two (2) window defrost fans will be mounted on the ceiling of the cab, one (1) on each side of the cab.

SUN VISORS

Two (2) smoked Lexan™ sun visors will be provided. The sun visors will be located above the windshield with one (1) mounted on each side of the cab.

There will be a black plastic thumb latch provided to help secure each sun visor in the stowed position.

GRAB HANDLES

A black rubber covered grab handle will be mounted on the door post of the driver and officer's side cab door to assist in entering the cab. The grab handles will be securely mounted to the post area between the door and windshield.



ENGINE COMPARTMENT LIGHT

An engine compartment light will be installed under the engine hood, of which the switch is an integral part. Light will have a .125" diameter hole in its lens to prevent moisture retention.

ACCESS TO ENGINE DIPSTICKS

For access to the engine oil and transmission fluid dipsticks, there will be a door on the engine tunnel, inside the crew cab. The door will be on the rear wall of the engine tunnel, on the vertical surface.

The engine oil dipstick will allow for checking only. The transmission dipstick will allow for both checking and filling.



The door will have a rubber seal for thermal and acoustic insulation. One (1) lift and turn latch will be provided on the access door.

STORAGE BOX

There will be four (4) storage box(es) designed to hold and dispense boxes of latex gloves provided.

Each box will be constructed of aluminum and located to be mounted at final inspection.

Each storage box will be 10.00" wide x 5.00" high x 3.50" deep and painted to match the cab interior. A slot will be provided on the top of each box to dispense the gloves.

MAP BOX

There will be a map box with two (2) bins, open at top, provided. The map box will be located to be mounted at final inspection. The map box will be divided into two (2) bins, each being 12.50" wide x 3.00" high x 12.00" deep. Each bin will slant 30 degrees from horizontal. The map box will be constructed of .125" aluminum and will be painted to match the cab interior.

CAB SAFETY SYSTEM

The cab will be provided with a safety system designed to protect occupants in the event of a side roll or frontal impact, and will include the following:

- A supplemental restraint system (SRS) sensor will be installed on a structural cab member behind the instrument panel. The SRS sensor will perform real time diagnostics of all critical subsystems and will record sensory inputs immediately before and during a side roll or frontal impact event.
- A slave SRS sensor will be installed in the cab to provide capacity for eight (8) crew cab seating positions.
- A fault-indicating light will be provided on the vehicle's instrument panel allowing the driver to monitor the operational status of the SRS system.
- A driver side front air bag will be mounted in the steering wheel and will be designed to protect the head and upper torso of the occupant, when used in combination with the 3-point seat belt.
- A passenger side knee bolster air bag will be mounted in the modesty panel below the dash panel and will be designed to protect the legs of the occupant, when used in combination with the 3-point seat belt.
- Air curtains will be provided in the outboard bolster of outboard seat backs to provide a cushion between occupant and the cab wall.
- Suspension seats will be provided with devices to retract them to the lowest travel position during a side roll or frontal impact event.
- Seat belts will be provided with pre-tensioners to remove slack from the seat belt during a side roll or frontal impact event.

Frontal Impact Protection

The SRS system will provide protection during a frontal or oblique impact event. The system will activate when the vehicle decelerates at a predetermined G force known to cause injury to the occupants. The cab and chassis will have been subjected, via third party test facility, to a crash impact during frontal and oblique impact testing. Testing included all major chassis and cab components such

as mounting straps for fuel and air tanks, suspension mounts, front suspension components, rear suspensions components, frame rail cross members, engine and transmission and their mounts, pump house and mounts, frame extensions and body mounts. The testing provided configuration specific information used to optimize the timing for firing the safety restraint system. The sensor will activate the pyrotechnic devices when the correct crash algorithm, wave form, is detected.

The SRS system will deploy the following components in the event of a frontal or oblique impact event:

- Driver side front air bag
- Passenger side knee bolster air bag
- Air curtains mounted in the outboard bolster of outboard seat backs
- Suspension seats will be retracted to the lowest travel position
- Seat belts will be pre-tensioned to firmly hold the occupant in place

Side Roll Protection

The SRS system will provide protection during a fast or slow 90 degree roll to the side, in which the vehicle comes to rest on its side. The system will analyze the vehicle's angle and rate of roll to determine the optimal activation of the advanced occupant restraints.

The SRS system will deploy the following components in the event of a side roll:

- Air curtains mounted in the outboard bolster of outboard seat backs
- Suspension seats will be retracted to the lowest travel position
- Seat belts will be pre-tensioned to firmly hold the occupant in place

SEATING CAPACITY

The seating capacity in the cab will be four (4).

DRIVER SEAT

A seat will be provided in the cab for the driver. The seat design will be a cam action type, with air suspension. For increased convenience, the seat will include a manual control to adjust the horizontal position (6.00" travel). The manual horizontal control will be a towel-bar style located below the forward part of the seat cushion. To provide flexibility for multiple driver configurations, the seat will have an adjustable reclining back. The seat back will be a high back style with side bolster pads for maximum support. For optimal comfort, the seat will be provided with 17.00" deep foam cushions designed with EVC (elastomeric vibration control).

The seat will include the following features incorporated into the side roll protection system:

- Side air curtain will be mounted integral to the outboard bolster of the seat back. The air curtain will be covered by a decorative panel when in the stowed position.
- A suspension seat safety system will be included. When activated in the event of a side roll, this system will pretension the seat belt and retract the seat to its lowest travel position.

The seat will be furnished with a 3-point, shoulder type seat belt.

OFFICER SEAT

A seat will be provided in the cab for the passenger. The seat will be a fixed type, with no suspension. For optimal comfort, the seat will be provided with 17.00" deep foam cushions designed with EVC (elastomeric vibration control).

The seat back will be an SCBA back style with 5 degree fixed recline angle. The SCBA cavity will be adjustable from front to rear in 1.00" increments, to accommodate different sized SCBA cylinders. Moving the SCBA cavity will be accomplished by unbolting, relocating, and re-bolting it in the desired location.

The seat will include the following features incorporated into the side roll protection system:

- Side air curtain will be mounted integral to the outboard bolster of the seat back. The air curtain will be covered by a decorative panel when in the stowed position.
- A seat safety system will be included. When activated, this system will pretension the seat belt.

The seat will be furnished with a 3-point, shoulder type seat belt.

RADIO COMPARTMENT

A radio compartment will be provided under the officer's seat.

The inside compartment dimensions will be 16.00" wide x 7.50" high x 15.00" deep, with the back of the compartment angled up to match the cab structure.

A drop-down door with one (1) flush lift and turn latch will be provided for access.

The compartment will be constructed of smooth aluminum and painted to match the cab interior.

REAR FACING DRIVER SIDE OUTBOARD SEAT

There will be one (1) rear facing seat provided at the driver side outboard position in the crew cab. For optimal comfort, the seat will be provided with 15.00" deep foam cushions designed with EVC (elastomeric vibration control).

The seat back will be an SCBA back style with 5 degree fixed recline angle. The SCBA cavity will be adjustable from front to rear in 1.00" increments, to accommodate different sized SCBA cylinders. Moving the SCBA cavity will be accomplished by unbolting, relocating, and re-bolting it in the desired location.

The seat will include the following features incorporated into the side roll protection system:

- Side air curtain will be mounted integral to the outboard bolster of the seat back. The air curtain will be covered by a decorative panel when in the stowed position.
- A seat safety system will be included. When activated, this system will pretension the seat belt.

The seat will be furnished with a 3-point, shoulder type seat belt.

REAR FACING PASSENGER SIDE OUTBOARD SEAT

There will be one (1) rear facing seat provided at the passenger side outboard position in the crew cab. For optimal comfort, the seat will be provided with 15.00" deep foam cushions designed with EVC (elastomeric vibration control).

The seat back will be an SCBA back style with 5 degree fixed recline angle. The SCBA cavity will be adjustable from front to rear in 1.00" increments, to accommodate different sized SCBA cylinders. Moving the SCBA cavity will be accomplished by unbolting, relocating, and re-bolting it in the desired location.

The seat will include the following features incorporated into the side roll protection system:

- Side air curtain will be mounted integral to the outboard bolster of the seat back. The air curtain will be covered by a decorative panel when in the stowed position.
- A seat safety system will be included. When activated, this system will pretension the seat belt.

The seat will be furnished with a 3-point, shoulder type seat belt.

FORWARD FACING CENTER CABINET

A forward facing cabinet will be provided in the crew cab at the center position.

The cabinet will be 38.50" wide x 50.00" high x 18.00" deep with one (1) Amdor rollup door with white finish, non-locking. The frame to frame opening of the cabinet will be 36.00" wide x 44.75" high. The minimum clear door opening will be 33.25" wide x 38.87" high.

CLEAR DOOR OPENINGS (F-F = Frame to Frame)					
AMDOR		GORTITE		ROM	
HORIZONTAL	VERTICAL	HORIZONTAL	VERTICAL	HORIZONTAL	VERTICAL
Subtract 2.00" from F-F	Subtract 5.88" from F-F	Subtract 2.75" from F-F	Subtract 4.75" from F-F	Subtract 2.56" from F-F	Subtract 4.50" from F-F

The cabinet will include two (2) infinitely adjustable shelves with a 1.25" up-turned lipped to match the cab interior.

The cabinet will include no louvers.

The cabinet will be constructed of smooth aluminum, and painted to match the cab interior.

Cabinet Light

There will be one (1) white LED strip light installed on the left side of the interior cabinet door opening and one (1) white LED strip light installed on the right side of the interior cabinet door opening. The lighting will be controlled by an automatic door switch.

MATTING IN EMS COMPARTMENT

Vinyl grating will be provided in three (3) EMS compartments, each shelf and floor of ems compartment. Tile color will be black.

The vinyl grating will be 0.50" thick and be cross bonded by 0.25" diameter ribbed sections spaced for aeration. The trim edge will not be installed at the edge of the tile.

SEAT UPHOLSTERY

All seat upholstery will be black Turnout Tuff material.

AIR BOTTLE HOLDERS

All SCBA type seats in the cab will have a "Hands-Free" auto clamp style bracket in its backrest. For efficiency and convenience, the bracket will include an automatic spring clamp that allows the occupant to store the SCBA bottle by simply pushing it into the seat back. For protection of all occupants in the cab, in the event of an accident, the inertial components within the clamp will constrain the SCBA bottle in the seat and will exceed the NFPA standard of 9G.

There will be a quantity of three (3) SCBA brackets.

SEAT BELTS

All cab and tiller cab (if applicable) seating positions will have red seat belts. To provide quick, easy use for occupants wearing bunker gear, the female buckle and seat belt webbing length will meet or exceed the current edition of NFPA 1901 and CAN/ULC - S515 standards.

The 3-point shoulder type seat belts will include height adjustment. This adjustment will optimize the belts effectiveness and comfort for the seated firefighter. The 3-point shoulder type seat belts will be furnished with dual automatic retractors that will provide ease of operation in the normal seating position.

The 3-point shoulder type belts will also include the ReadyReach D-loop assembly to the shoulder belt system. The ReadyReach feature adds an extender arm to the D-loop location placing the D-loop in a closer, easier to reach location.

Any flip up seats will include a 3-point shoulder type belts only.

To ensure safe operation, the seats will be equipped with seat belt sensors in the seat cushion and belt receptacle that will activate an alarm indicating a seat is occupied but not buckled.

HELMET STORAGE PROVIDED BY FIRE DEPARTMENT

NFPA 1901, 2016 edition, section 14.1.7.4.1 requires a location for helmet storage be provided.

There is no helmet storage on the apparatus as manufactured. The fire department will provide a location for storage of helmets.

CAB DOME LIGHTS

There will be four (4) dual LED dome lights with grey bezels provided. Two (2) lights will be mounted above the inside shoulder of the driver and officer and two (2) lights will be installed and located, one (1) on each side of the crew cab.

The color of the LED's will be red and white.

The white LED's will be controlled by the door switches and the lens switch.

The color LED's will be controlled by the lens switch.

In order to ensure exceptional illumination, each white LED dome light will provide a minimum of 10.1 foot-candles (fc) covering an entire 20.00" x 20.00" square seating position when mounted 40.00" above the seat.

HAND HELD LIGHT

There will be three (3) Streamlight, Vulcan, Model #44315, hand lights provided with a vehicle mount with 12VDC direct wire charging rack and quick release buckle strap mounted at pickup.

Each light housing will be orange in color.

HAND HELD LIGHT

There will be two (2) lights Streamlight E-Flood LiteBox, Model 45805, LED hand lights with the orange thermoplastic body and dual rear LEDs provided. These will be mounted TBD.

The light will be provided with a 12 volt charger.

CAB INSTRUMENTATION

The cab instrument panel will include gauges, telltale indicator lamps, control switches, alarms, and a diagnostic panel. The function of the instrument panel controls and switches will be identified by a label adjacent to each item. Actuation of the headlight switch will illuminate the labels in low light conditions. Telltale indicator lamps will not be illuminated unless necessary. The cab instruments and controls will be conveniently located within the forward cab section, forward of the driver. The gauge assembly and switch panels are designed to be removable for ease of service and low cost of ownership.

Gauges

The gauge panel will include the following ten (10) black faced gauges with black bezels to monitor vehicle performance:

- Voltmeter gauge (volts):
 - Low volts (11.8 VDC)
 - Amber telltale light on indicator light display with steady tone alarm
 - High volts (15.5 VDC)
 - Amber telltale light on indicator light display with steady tone alarm
- Engine Tachometer (RPM)
- Speedometer MPH (Major Scale), KM/H (Minor Scale)
- Fuel level gauge (Empty - Full in fractions):
 - Low fuel (1/8 full)
 - Amber indicator light in gauge dial with steady tone alarm
- Engine Oil pressure Gauge (PSI):
 - Low oil pressure to activate engine warning lights and alarms
 - Red indicator light in gauge dial with steady tone alarm
- Front Air Pressure Gauges (PSI):
 - Low air pressure to activate warning lights and alarm
 - Red indicator light in gauge dial with steady tone alarm

- Rear Air Pressure Gauges (PSI):
 - Low air pressure to activate warning lights and alarm
 - Red indicator light in gauge dial with steady tone alarm
- Transmission Oil Temperature Gauge (Fahrenheit):
 - High transmission oil temperature activates warning lights and alarm
 - Amber indicator light in gauge dial with steady tone alarm
- Engine Coolant Temperature Gauge (Fahrenheit):
 - High engine temperature activates an engine warning light and alarms
 - Red indicator light in gauge dial with steady tone alarm
- Diesel Exhaust Fluid Level Gauge (Empty - Full in fractions):
 - Low fluid (1/8 full)
 - Amber indicator light in gauge dial

Indicator Lamps

To promote safety, the following telltale indicator lamps will be located on the instrument panel in clear view of the driver. The indicator lamps will be "dead-front" design that is only visible when active. The colored indicator lights will have descriptive text or symbols.

The following amber telltale lamps will be present:

- Low coolant
- Trac cntl (traction control) (where applicable)
- Check engine
- Check trans (check transmission)
- Air rest (air restriction)
- DPF (engine diesel particulate filter regeneration)
- HET (engine high exhaust temperature) (where applicable)
- ABS (antilock brake system)
- MIL (engine emissions system malfunction indicator lamp) (where applicable)
- Regen inhibit (engine emissions regeneration inhibit) (where applicable)
- Side roll fault (where applicable)
- Front air bag fault (where applicable)
- Aux brake overheat (auxiliary brake overheat) (where applicable)
- The following red telltale lamps will be present:
- Ladder rack down
- Parking brake
- Stop engine
- The following green telltale lamps will be present:
- Left turn
- Right turn
- Battery on
- Ignition
- Aux brake (auxiliary brake engaged) (where applicable)
- The following blue telltale lamps will be present:

- High beam

Alarms

Audible steady tone warning alarm: A steady audible tone alarm will be provided whenever a warning condition is active.

Indicator Lamp and Alarm Prove-Out

A system will be provided which automatically tests telltale indicator lights and alarms located on the cab instrument panel. Telltale indicators and alarms will perform prove-out for 3 to 5 seconds when the ignition switch is moved to the on position with the battery switch on.

Control Switches

For ease of use, the following controls will be provided immediately adjacent to the cab instrument panel within easy reach of the driver. All switches will have backlit labels for low light applications.

Headlight/Parking light switch: A three (3)-position maintained rocker switch will be provided. The first switch position will deactivate all parking and headlights. The second switch position will activate the parking lights. The third switch will activate the headlights.

Panel back lighting intensity control switch: A three (3)-position momentary rocker switch will be provided. Pressing the top half of the switch, "Panel Up" increases the panel back lighting intensity and pressing the bottom half of the switch, "Panel Down" decreases the panel back lighting intensity. Pressing the half or bottom half of the switch several times will allow back lighting intensity to be gradually varied from minimum to maximum intensity level for ease of use.

Ignition switch: A three (3)-position maintained/momentary rocker switch will be provided. The first switch position will turn off and deactivate vehicle ignition. The second switch position will activate vehicle ignition and will perform prove-out on the telltale indicators and alarms for 3 to 5 seconds after the switch is turned on. A green indicator lamp is activated with vehicle ignition. The third momentary position will temporarily silence all active cab alarms. An alarm "chirp" may continue as long as alarm condition exists. Switching ignition to off position will terminate the alarm silence feature and reset function of cab alarm system.

Engine start switch: A two (2)-position momentary rocker switch will be provided. The first switch position is the default switch position. The second switch position will activate the vehicle's engine. The switch actuator is designed to prevent accidental activation.

Hazard switch will be provided on the instrument panel or on the steering column.

Heater, defrost, and air conditioning control panel.

Turn signal arm: A self-canceling turn signal with high beam headlight controls.

Windshield wiper control will have high, low, and intermittent modes.

Parking brake control: An air actuated push/pull park brake control.

Chassis horn control: Activation of the chassis horn control will be provided through the center of the steering wheel.

High idle engagement switch: A maintained rocker switch with integral indicator lamp will be provided. The switch will activate and deactivate the high idle function. The "OK To Engage High Idle" indicator lamp must be active for the high idle function to engage. A green indicator lamp integral to the high idle engagement switch will indicate when the high idle function is engaged.

"OK To Engage High Idle" indicator lamp: A green indicator light will be provided next to the high idle activation switch to indicate that the interlocks have been met to allow high idle engagement.

Emergency switching will be controlled by multiple individual warning light switches for various groups or areas of emergency warning lights. An Emergency Master switch provided on the instrument panel that enables or disables all individual warning light switches is included.

An additional "Emergency Master" button will be provided on the lower left hand corner of the gauge panel to allow convenient control of the "Emergency Master" system from inside the driver's door when standing on the ground.

Custom Switch Panels

The design of cab instrumentation will allow for emergency lighting and other switches to be placed within easy reach of the operator thus improving safety. There will be positions for up to four (4) switch panels in the lower instrument console and up to six (6) switch panels in the overhead visor console. All switches have backlit labels for low light conditions.



Diagnostic Panel

A diagnostic panel will be provided and accessible while standing on the ground. The panel will be located inside the driver's side door left of the steering column. The diagnostic panel will allow diagnostic tools such as computers to connect to various vehicle systems for improved troubleshooting providing a lower cost of ownership. Diagnostic switches will allow ABS systems to provide blink codes should a problem exist.

The diagnostic panel will include the following:

- ENGINE/TRANSMISSION/ABS J1939 Diagnostic Port
- ABS Diagnostic Switch and Indicator - The switch and amber indicator will allow access to diagnostic mode and display of standard ABS system fault blink codes that may be generated by the ABS system
- DPF REGEN (Diesel Particulate Filter Regeneration Switch) (where applicable) will be provided to request regeneration of the engine emission system. An amber indicator will be provided on top of the switch that will illuminate in a "CHECK ENGINE" condition
- REGEN INHIBIT (Diesel Particulate Filter Regeneration Inhibit Switch) (where applicable) will be provided that will request that regeneration be temporarily prevented. A green indicator will

be provided on top of the Regen Inhibit switch that will illuminate when the Regen Inhibit feature is active. Regen Inhibit will be disabled upon cycling of the ignition switch to the off state.

AIR RESTRICTION INDICATOR

A high air restriction warning indicator light (electronic) will be provided.

"DO NOT MOVE APPARATUS" INDICATOR

A flashing red indicator light, located in the driving compartment, will be illuminated automatically per the current NFPA requirements. The light will be labeled "Do Not Move Apparatus If Light Is On."

The same circuit that activates the Do Not Move Apparatus indicator will activate a pulsing alarm when the parking brake is released.

SWITCH PANELS

The built-in switch panels will be located in the lower console or overhead console of the cab. Switches will be rocker type with an indicator light, of which is an integral part of the switch.

WIPER CONTROL

Wiper control will consist of a two (2)-speed windshield wiper control with intermittent feature and windshield washer controls. The control will be located on the left side of the center instrument panel.

SPARE CIRCUIT

There will be two (2) dual USB fast charge socket mounts installed on the apparatus.

The above wires will have the following features:

- The positive wire will be connected directly to the battery power.
- The negative wire will be connected to ground.
- Wires will be protected to 4.8 amps at 12 volts DC.
- The USB socket mount will be TBD.
- Termination will be a Blue Sea Systems part number 1045 dual USB charger socket.
- Wires will be sized to 125% of the protection.

This circuit(s) may be load managed when the parking brake is applied.

SPARE CIRCUIT

There will be three (3) pair of wires, including a positive and a negative, installed on the apparatus.

The above wires will have the following features:

- The positive wire will be connected directly to the battery power.
- The negative wire will be connected to ground.
- Wires will be protected to 50 amps at 12 volts DC.
- Power and ground will terminate Med cabinet centered up high, behind officer seat, in cabinet TBD.
- Termination will be to a Blue Sea System, Model 5025, 6 circuit with negative bus bar. The terminal block will include a cover with circuit labels.

Wires will be sized to 125% of the protection.

This circuit(s) may be load managed when the parking brake is set.

CUSTOMER SUPPLIED RADIO WIRING

There will be two (2) 12 volt combination wiring leads of which each will include one (1) direct battery, one (1) ignition and one (1) negative for use with radio equipment.

Each lead will be 18.00" long and be provided center dash switch panel. The leads will be clearly marked in a coil and terminate with butt splices.

A breaker rated for 30 amps will be provided for circuit protection of the direct battery lead with a minimum of 10 gauge wire.

A breaker rated for 7.5 amps will be provided for circuit protection of the ignition lead.

The wires will be colored coded as follows:

- red for direct battery
- yellow for ignition
- black for ground

INFORMATION CENTER

There will be a LCD display integral to the cab gauge panel provided that will display the following information:

- Total distance
- Trip distance
- Total hours
- Trip hours
- PTO "A" hours
- PTO "B" hours

COLLISION MITIGATION

There will be a HAAS Alert®, Model HA5 Responder-to-Vehicle (R2V) collision avoidance system provided on the apparatus. The HA5 cellular transponder module will be installed behind the cab windshield, as high and near to the center as practical, to allow clear visibility to the sky. The module dimensions are 5.40" long x 2.70" wide x 1.30" high, and operating temperature range is -40 degree C to 85 degree C.

The transponder will be connected to the vehicle's emergency master circuit and battery direct power and ground.

While responding with emergency lights on, the HA5 transponder sends alert messages via cellular network to motorists in the vicinity of the responding truck that are equipped with the WAZE app.

While on scene with emergency lights on, the HA5 transponder sends road hazard alerts to motorists in the vicinity of the truck that are equipped with the WAZE app.

The HA5 Responder-to-Vehicle (R2V) collision avoidance system will include the transponder and a 5 year cellular plan subscription.

Activation of the HAAS Alert system requires a representative of the customer to accept the End User License Agreement (EULA) via an on-line portal.

VEHICLE DATA RECORDER

There will be a vehicle data recorder (VDR) capable of reading and storing vehicle information provided.

The information stored on the VDR can be downloaded through a USB port mounted in a convenient location determined by cab model. A USB cable can be used to connect the VDR to a laptop to retrieve required information. The program to download the information from the VDR will be available to download on-line.

The vehicle data recorder will be capable of recording the following data via hardwired and/or CAN inputs:

- Vehicle Speed - MPH
- Acceleration - MPH/sec
- Deceleration - MPH/sec
- Engine Speed - RPM
- Engine Throttle Position - % of Full Throttle
- ABS Event - On/Off
- Seat Occupied Status - Yes/No by Position
- Seat Belt Buckled Status - Yes/No by Position
- Master Optical Warning Device Switch - On/Off
- Time - 24 Hour Time
- Date - Year/Month/Day

Seat Belt Monitoring System

A seat belt monitoring system (SBMS) will be provided. The SBMS will be capable of monitoring up to 10 seating positions indicating the status of each seat position per the following:

- Seat Occupied & Buckled = Green LED indicator illuminated
- Seat Occupied & Unbuckled = Red LED indicator with audible alarm
- No Occupant & Buckled = Red LED indicator with audible alarm
- No Occupant & Unbuckled = No indicator and no alarm

The SBMS will include an audible alarm that will warn that an unbuckled occupant condition exists and the parking brake is released, or the transmission is not in park.

INTERCOM SYSTEM

A four (4) position intercom system with dual radio interface capability at the driver and officer positions and remote push to transmit buttons located TBD will be provided. Two (2) crew cab positions, located at both rear facing seats, will have radio listen / intercom only.

The following David Clark components will be supplied with this system:

- Two (2) U3805 Radio Cord Junction Modules
- Two (2) U3816 Dual Radio Interface Modules (Driver, Officer)
- Four (4) Remote Transmit button kits
- One (1) U3800 Intercom Unit (1 Crew)
- One (1) C3820 Power Cable.
- One (1) U3801 Intercom Unit (1 Crew)
- All necessary cables and connectors

RADIO / INTERCOM INTERFACE INCLUDED

All radio interfaced stations will have universal radio interfaces installed. The interface wiring will be routed within the cab to TBD .

UNDER THE HELMET HEADSET

There will be two (2) under the helmet, headset(s) provided front seats.

Each David Clark, Model H3442, headset will feature:

- 5' Coiled cord
- Noise cancelling electric microphone
- Flexible microphone boom rotates 200 degrees for left or right dress
- Microphone on/off button
- Comfort Gel Earseals
- 23 dB noise reduction



OVER THE HEAD HEADSET

There will be two (2) over the head, headset(s) provided rear seats.

Each David Clark, Model H3432, headset will feature:

- 5' Coiled cord
- Noise cancelling electric microphone
- Flexible microphone boom rotates 200 degrees for left or right dress
- Microphone on/off button
- Comfort Gel Earseals
- 23 dB noise reduction



HEADSET HANGERS

There will be five (5) headset hanger(s) installed driver's seat, officer's seat, driver's side outboard forward facing seat, passenger's side outboard forward facing seat and rear, center, forward facing seat. The hanger(s) will meet NFPA 1901, Section 14.1.11, requirement for equipment mounting.

RADIO ANTENNA MOUNT

There will be two (2) standard 1.125", 18 thread antenna-mounting base(s) installed one (1) on the left side and one (1) on the right side on the cab roof with high efficiency, low loss, coaxial cable(s) routed to the instrument panel area. A weatherproof cap will be installed on the mount.



VEHICLE CAMERA SYSTEM

There will be a color vehicle camera system provided with the following:

- One (1) Analog High Definition (AHD) black camera located at the rear of the apparatus, pointing rearward, displayed automatically with the vehicle in reverse.
- One (1) AHD camera located on the right side of the apparatus, pointing rearward, displayed automatically with the right side turn signal.
- One (1) AHD camera located on the left side of the apparatus, pointing rearward, displayed automatically with the left side turn signal.

The camera images will be displayed on a 7.00" High Definition (HD) display located in view of the driver on the dash. The display will include manual camera activation capability and audio from the rear camera only.

The following components will be included:

- One (1) HD700136DC Display
- One (1) 1080p AHD Rear camera
- Two (2) 1080p AHD Side cameras
- All necessary cables

VEHICLE CAMERA GUARD

There will be one (1) aluminum treadplate guard(s) fastened over the vehicle camera(s) located center rear .

ELECTRICAL POWER CONTROL SYSTEM

A compartment will be provided in or under the cab to house the vehicle's electrical power and signal circuit protection and control components. The power and signal protection and control compartment will contain circuit protection devices and power control devices. Power and signal protection and control components will be protected against corrosion, excessive heat, excessive vibration, physical damage and water spray.

Serviceable components will be readily accessible.

Circuit protection devices, which conform to SAE standard, will be utilized to protect each circuit. All circuit protection devices will be sized to prevent wire and component damage when subjected to extreme current overload. General protection circuit breakers will be Type-I automatic reset (continuously resetting) and conform to SAE J553 or J258. When required, automotive type fuses conforming to SAE J554, J1284, J1888 or J2077 will be utilized to protect electronic equipment.

Power control relays and solenoids will have a direct current (dc) rating of 125 percent of the maximum current for which the circuit is protected.

Visual status indicators will be supplied to identify control safety interlocks and vehicle status. In addition to visual status indicators, audible alarms designed to provide early warning of problems before they become critical will be used.

VOLTAGE MONITOR SYSTEM

A voltage monitor system will be provided to indicate the status of each battery system connected to the vehicle's electrical load. The monitor system will provide visual and audio warning when the system voltage is above or below optimum levels.

POWER AND GROUND STUDS

Spare circuits will be provided in the primary distribution center for two-way radio equipment.

The spare circuits will consist of the following:

- One (1) 12-volt DC, 30 amp battery direct spare
- One (1) 12-volt DC ground and un-fused switched battery stud located in or adjacent to the power distribution center

EMI/RFI PROTECTION

The electrical system proposed will include means to control undesired electromagnetic and radio frequency emissions. State of the art electrical system design and components will be used to ensure radiated and conducted EMI (electromagnetic interference) and RFI (radio frequency interference) emissions are suppressed at their source.

The apparatus proposed will have the ability to operate in the electromagnetic environment typically found in fire ground operations. The contractor will be able to demonstrate the EMI and RFI testing has been done on similar apparatus and certifies that the vehicle proposed meets SAE J551 requirements.

EMI/RFI susceptibility will be controlled by applying immune circuit designs, shielding, twisted pair wiring and filtering. The electrical system will be designed for full compatibility with low level control signals and high powered two-way radio communication systems. Harness and cable routing will be given careful attention to minimize the potential for conducting and radiated EMI-RFI susceptibility.

ELECTRICAL

All 12-volt electrical equipment installed by Pierce Manufacturing will conform to modern automotive practices. All wiring will be high temperature crosslink type. Wiring will be run, in loom or conduit, where exposed and have grommets where wire passes through sheet metal. Automatic reset circuit breakers will be provided which conform to SAE Standards. Wiring will be color, function and number coded. Function and number codes will be continuously imprinted on all wiring harness conductors at 2.00" intervals. Exterior exposed wire connectors will be positive locking, and environmentally sealed to withstand elements such as temperature extremes, moisture and automotive fluids.

Electrical wiring and equipment will be installed utilizing the following guidelines:

1. All holes made in the roof will be caulked with silicon. Large fender washers, liberally caulked, will be used when fastening equipment to the underside of the cab roof.
2. Any electrical component that is installed in an exposed area will be mounted in a manner that will not allow moisture to accumulate in it. Exposed area will be defined as any location outside of the cab or body.
3. Electrical components designed to be removed for maintenance will not be fastened with nuts and bolts. Metal screws will be used in mounting these devices. Also, a coil of wire will be provided behind the appliance to allow them to be pulled away from mounting area for inspection and service work.
4. Corrosion preventative compound will be applied to all terminal plugs located outside of the cab or body. All non-waterproof connections will have this compound in the plug to prevent corrosion and for easy separation (of the plug).
5. All lights that have their sockets in a weather exposed area will have corrosion preventative compound added to the socket terminal area.
6. All electrical terminals in exposed areas will have silicon applied completely over the metal portion of the terminal.

All lights and reflectors, required to comply with Federal Motor Vehicle Safety Standard #108, will be furnished. Rear identification lights will be recessed mounted for protection.

Lights and wiring mounted in the rear bulkheads will be protected from damage by installing a false bulkhead inside the rear compartments.

An operational test will be conducted to ensure that any equipment that is permanently attached to the electrical system is properly connected and in working order.

The results of the tests will be recorded and provided to the purchaser at time of delivery.

BATTERY SYSTEM

There will be four (4) 12 volt Exide®, Model 31S950X5W, batteries that include the following features will be provided:

- 950 CCA, cold cranking amps
- 190 amp reserve capacity
- High cycle
- Group 31
- Rating of 3800 CCA at 0 degrees Fahrenheit
- 760 minutes of reserve capacity
- Threaded stainless steel studs

Each battery case will be a black polypropylene material with a vertically ribbed container for increased vibration resistance. The cover will be manifold vented with a central venting location to allow a 45 degree tilt capacity.

The inside of each battery will consist of a "maintenance free" grid construction with poly wrapped separators and a flooded epoxy bottom anchoring for maximum vibration resistance.

BATTERY SYSTEM

There will be a single starting system with an ignition switch and starter button provided and located on the cab instrument panel.

MASTER BATTERY SWITCH

There will be a master battery switch provided within the cab within easy reach of the driver to activate the battery system.

An indicator light will be provided on the instrument panel to notify the driver of the status of the battery system.

BATTERY COMPARTMENTS

Batteries will be placed on non-corrosive mats and stored in well ventilated compartments located under the cab.

Heavy-duty, 2/0 gauge, color coded battery cables will be provided. Battery terminal connections will be coated with anti-corrosion compound.

Battery solenoid terminal connections will be encapsulated with semi-permanent rubberized compound.

JUMPER STUDS

One (1) set of battery jumper studs with plastic color-coded covers will be included on the battery compartments.

BATTERY CHARGER

There will be an IOTA™, Model DSL 75, battery charger with IQ4, controller provided.

The battery charger will be wired to the AC shoreline inlet through an AC receptacle adjacent to this battery charger.

There will be a Kussmaul™, Model #091-94-12, remote indicator included.

Battery charger will be located in the cab behind the driver seat

The battery charger indicator will be located in the driver's step area.

SHORELINE INLET

There will be one (1) Blue Sea Sure Eject™ part number 7851, 20 amp 120 volt AC shoreline inlet provided to operate the dedicated 120 volt AC circuits on the apparatus.

The shoreline will be connected to charger / shoreline.

The shoreline inlet cover color to be red.

The connector body will be released from the inlet when the apparatus engine start button is activated.

There will be a mating connector body supplied with the loose equipment.

There will be a label installed near the inlet(s) that state the following:

- Line Voltage
- Current Rating (amps)
- Phase
- Frequency

The shoreline receptacle will be located on the driver side seat riser.

ELECTRIC POWER FOR WINCH

Electric power provisions will be furnished for the portable winch from the chassis battery system.

The receiver plug will be located rear receiver hitch.

A total quantity of one (1) receptacle will be provided.

ALTERNATOR

A Delco Remy®, Model 40SI, alternator will be provided. It will have a rated output current of 320 amps, as measured by SAE method J56. The alternator will feature an integral regulator and rectifier system that has been tested and qualified to an ambient temperature of 257 degrees Fahrenheit (125 degrees Celsius). The alternator will be connected to the power and ground distribution system with heavy-duty cables sized to carry the full rated alternator output.

ELECTRONIC LOAD MANAGEMENT

An electronic load management (ELM) system that monitors the vehicles 12-volt electrical system, and automatically reduces the electrical load in the event of a low voltage condition and by doing so, ensures the integrity of the electrical system.

The ELM will monitor the vehicle's voltage while at the scene (parking brake applied). It will sequentially shut down individual electrical loads when the system voltage drops below a preset value. Two (2) separate electrical loads will be controlled by the load manager. The ELM will sequentially re-energize electrical loads as the system voltage recovers.

HEADLIGHTS

There will be four (4) JW Speaker®, heated rectangular LED lights mounted in the front quad style, chrome housing on each side of the front bumper:

- the outside light on each side will contain a part number 055***1 low beam module
- the inside light on each side will contain a part number 055***1 high beam module
- the headlights to include chrome bezels

The low beam lights will be activated when the headlight switch is on.

The high beam and low beam lights will be activated when the headlight switch and the high beam switch is activated.

FRONT DIRECTIONALS

The front directional's will be Whelen®, Model M62T, 4.31" high x 6.75" wide x 1.37" deep directional lights with amber LEDs. The lens color(s) to be clear. The directional's will be housed in the same

common bezel as the front warning light and will be located above the headlights. The housing to be polished and the trim shall be chrome.

The flash pattern of the directional lights will be Sequence (Slow) to Solid - Steady On.

INTERMEDIATE LIGHT

There will be two (2) Weldon, Model 9186-8580-29, amber LED turn signal marker lights furnished, one (1) each side, in the rear fender panel. The light will double as a turn signal and marker light.

CAB CLEARANCE/MARKER/ID LIGHTS

There will be five (5) amber LED lights provided to indicate the presence and overall width of the vehicle in the following locations:

- Three (3) amber LED identification lights will be installed in the center of the cab above the windshield.
- Two (2) amber LED clearance lights will be installed, one (1) on each outboard side of the cab above the windshield.

FRONT CAB SIDE DIRECTIONAL/MARKER LIGHTS

There will be two (2) Weldon, Model 9186-8580-29, amber LED lights installed front of the cab door, one (1) on each side of the cab.

The lights will activate as marker lights with the headlight switch and directional lights with the corresponding directional circuit.

REAR CLEARANCE/MARKER/ID LIGHTING

There will be three (3) Truck-Lite®, Model 33050R, LED lights used as identification lights recessed and located at the rear of the apparatus per the following:

- As close as practical to the vertical centerline
- Centers spaced not less than 6.00" or more than 12.00" apart
- Red in color
- All at the same height

There will be two (2) Truck-Lite, Model 33050R, LED lights recessed at the rear of the apparatus used as clearance lights located at the rear of the apparatus per the following:

- To indicate the overall width of the vehicle
- One (1) each side of the vertical centerline
- As near the top as practical
- Red in color
- To be visible from the rear
- All at the same height

There will be two (2) Truck-Lite, Model 33050R, LED lights recessed on the side of the apparatus as marker lights as close to the rear as practical per the following:

- To indicate the overall length of the vehicle
- One (1) each side of the vertical centerline
- As near the top as practical
- Red in color
- To be visible from the side
- All at the same height

There will be two (2) red reflectors located on the rear of the truck facing to the rear. One (1) each side, as far to the outside as practical, at a minimum of 15.00", but no more than 60.00", above the ground.

There will be two (2) red reflectors located on the side of the truck facing to the side. One (1) each side, as far to the rear as practical, at a minimum of 15.00", but no more than 60.00", above the ground.

Per FMVSS 108 and CMVSS 108 requirements.

REAR FMVSS LIGHTING

The rear stop/tail and directional lighting included in the rear tail light housing will include the following:

- Two (2) Whelen®, Model M62BTT, 4.30" high x 6.70" wide x 1.40" deep brake/tail lights with red LEDs
- Two (2) Whelen, Model M62T, 4.30" high x 6.70" wide x 1.40" deep directional lights with amber LEDs. The directional lights will be set to Sequence (Slow) to Solid - Steady On flash pattern.
- The lens color(s) to be clear.

There will be two (2) Whelen Model M62BU, LED backup lights provided in the tail light housing.

LICENSE PLATE BRACKET

One (1) license plate bracket constructed of stainless steel will be provided at the rear of the apparatus.

One (1) white LED light with chrome housing will be provided to illuminate the license plate. A stainless steel light shield will be provided over the light that will direct illumination downward, preventing white light to the rear.

LIGHTING BEZEL

There will be two (2) Whelen, Model M6FCV4P, four (4) place chromed ABS housings with Pierce logos provided for the rear M6 series stop/tail, directional, back up, scene lights or warning lights.

BACK-UP ALARM

A PRECO, Model 1040, solid-state electronic audible back-up alarm that actuates when the truck is shifted into reverse will be provided. The device will sound at 60 pulses per minute and automatically adjust its volume to maintain a minimum ten (10) dBA above surrounding environmental noise levels.

SWITCH, BACK-UP ALARM OVERRIDE

There will be a momentary switch provided in the cab for the back-up alarm. The switch will be within reach of the driver. The switch will cancel the back-up alarm when the switch is pushed and automatically reset when the apparatus is shifted out of reverse.

CAB PERIMETER SCENE LIGHTS

There will be four (4) Amdor, Model AY-LB-12HW012, 190 lumens each, 12.00" white LED strip lights provided.

- One (1) under the driver's side cab access step.
- One (1) under the passenger's side cab access step.
- One (1) under the passenger's side crew cab access step.
- One (1) under the driver's side crew cab access step.

The lights will be activated when the battery switch is on and the respective door is open and whenever control has been selected for the body perimeter lights.

PUMP HOUSE PERIMETER LIGHTS

There will be two (2) Amdor, Model AY-LB-12HW012, 190 lumens each, 12.00" LED weatherproof strip lights with brackets provided under the pump panel running boards, centered front to rear as much as possible, one (1) each side.

The lights will be activated when the battery switch is on, and controlled by the same means as the body perimeter lights.

BODY PERIMETER SCENE LIGHTS

There will be two (2) Amdor, Model AY-LB-12HW012, 190 lumens each, 12.00" 12 volt DC LED strip lights provided at the rear step area of the body, one (1) each side shining to the rear.

The perimeter scene lights will be activated when a switch within reach of the driver is activated, the parking brake is applied and either directional light is activated, activating all side facing perimeter lights.

ADDITIONAL PERIMETER LIGHTS

There will be six (6) lights Amdor®, Model AY-LB-12HW012, 190 lumens each, 12.00" white LED perimeter light(s) provided one (1) light under each side of the front bumper spaced evenly, one (1) light under compartment LS1, one (1) light under compartment LS3, one (1) light under compartment RS1 and one (1) light under compartment RS3.

These lights will be activated the same as the body perimeter lights.

STEP LIGHTS

There will be two (2) white LED step lights will be provided at the rear to illuminate the tailboard/step area.

In order to ensure exceptional illumination, each light will provide a minimum of 25 foot-candles (fc) covering an entire 15" x 15" square placed ten (10) inches below the light and a minimum of 1.5 fc covering an entire 30" x 30" square at the same ten (10) inch distance below the light.

These step lights will be actuated with the perimeter scene lights.

All other steps on the apparatus will be illuminated per the current edition of NFPA 1901.

12 VOLT LIGHTING

There will be one (1) HiViz Model FT-MB-33-**-*, 2.56" high x 42.44" long x 2.45" deep 12,210 effective lumens 12 volt DC LED light(s) with a combination of flood and spot optics provided on the front visor, centered.

The painted parts of the light housing and brackets to be painted job color.

The light(s) will be controlled by a switch at the driver's side switch panel, by a switch at the left side pump panel and by a switch at the passenger's side switch panel.

The light(s) may be load managed when the parking brake is applied.

12 VOLT LIGHTING

There will be a HiViz®, Model FT-B-46-**-*, 2.06" high x 46.00" long x 2.45" deep, 19,008 raw lumens, 12 volt DC light with white LEDs, and adjustable mounting brackets installed on the cab driver side cab centered above cab canopy window . The light(s) to be installed on 30 degree angled bracket(s) raising the light(s) off the roof of the cab and to the outside of the cab.

The painted parts of the light housing and brackets to be black.

The light(s) will be activated by a switch at the driver's side switch panel, by a switch at the left side pump panel and by a switch at the passenger's side switch panel.

The white LEDs may be load managed when the parking brake is applied.

12 VOLT LIGHTING

There will be a HiViz®, Model FT-B-46-**-*, 2.06" high x 46.00" long x 2.45" deep, 19,008 raw lumens, 12 volt DC light with white LEDs, and adjustable mounting brackets installed on the cab officer side cab centered above cab canopy window . The light(s) to be installed on 30 degree angled bracket(s) raising the light(s) off the roof of the cab and to the outside of the cab.

The painted parts of the light housing and brackets to be black.

The light(s) will be activated by a switch at the driver's side switch panel, by a switch at the left side pump panel and by a switch at the passenger's side switch panel.

The white LEDs may be load managed when the parking brake is applied.

12 VOLT LIGHTING

There will one (1) HiViz Model FT-B-46-**-*, 13,306 lumens 2.56" high x 46.00" long x 2.45" deep 12 volt DC light(s) with white LEDs and with a combination of spot, and flood optics installed on the apparatus located, driver side body centered recessed .

The painted parts of the light housing and brackets to be black.

The light(s) will be controlled by the same control that has been selected for the driver's side scene light(s).

The light(s) may be load managed when the parking brake is applied.

12 VOLT LIGHTING

There will be one (1) HiViz Model FT-B-46-*-* , 13,306 lumens 2.56" high x 46.00" long x 2.45" deep 12 volt DC light(s) with white LEDs and with a combination of spot, and flood optics installed on the apparatus located, officer side body centered .

The painted parts of the light housing and brackets to be black.

The light(s) will be controlled by the same control that has been selected for the passenger's side scene light(s).

The light(s) may be load managed when the parking brake is applied.

HOUSING TO MOUNT RECESSED LIGHT ONTO A HORIZONTAL SURFACE

There will be one (1) housings fabricated with painted aluminum installed on the apparatus driver side body scene light for the 12 volt DC recessed lights.

12 VOLT LIGHTING

There will be one (1) HiViz Model FT-B-46-*-* , 13,306 lumens 2.56" high x 46.00" long x 2.45" deep 12 volt DC light(s) with white LEDs and with a combination of spot, and flood optics installed on the apparatus located, on cross bar of hard hose bed cover, centered.

The painted parts of the light housing and brackets to be black.

The light(s) will be controlled by a switch at the driver's side switch panel, by a switch at the left side pump panel, by a switch at the passenger's side switch panel, by a switch in a recessed cup located at the driver's side rear bulkhead and side lights activated when shifting the chassis transmission into reverse when the emergency master switch is on.

The light(s) may be load managed when the parking brake is applied.

HOSE BED LIGHTS

There will be white 12 volt DC LED light strips with stainless steel protective cover, provided to light the hose bed area. Hose Bed lights will meet the photometric levels listed in NFPA 1901 for Hose Bed lighting requirements.

- Light strip(s) will be installed along the upper edge of the left side of the hose bed.
- Light strip(s) will be installed along the upper edge of the right side of the hose bed.

The lights will be activated by a cup switch at the rear of the apparatus no more than 72.00" from the ground.

WALKING SURFACE LIGHT

There will be two (2) Model FRP, 4" round black 12 volt DC LED light(s) with bolt mount provided on one hose bed cover, one on dunnage area, see drawing to illuminate the designated walking surface on top of the body.

The light(s) will be activated when the body step lights are on.

FRONT WHITE WARNING LIGHT CONTROL

There will be switch(es) installed in the cab on the switch panel that will allow the operator to activate/deactivate all the front white warning lights whenever the emergency master switch is activated and the parking brake is released. The headlight flash option is included in this white warning light control if applicable. Each time the emergency master switch is activated, and the parking brake is released, the white warning light control switch and the white warning lights will default to on.

SWITCH, RED

There will be one (1) red switch(s) that will replace the existing switch(s) for the emergency master located emergency master.

WATER TANK

Booster tank will have a capacity of 750 gallons and be constructed of polypropylene plastic by United Plastic Fabricating, Incorporated.

The tank will be stepped in design to allow for a low hosebed.

Tank joints and seams will be nitrogen welded inside and out.

Tank will be baffled in accordance with NFPA Bulletin 1901 requirements.

Baffles will have vent openings at both the top and bottom to permit movement of air and water between compartments.

Longitudinal partitions will be constructed of .38" polypropylene plastic and will extend from the bottom of the tank through the top cover to allow for positive welding.

Transverse partitions will extend from 4.00" off the bottom of the tank to the underside of the top cover.

All partitions will interlock and will be welded to the tank bottom and sides.

Tank top will be constructed of .50" polypropylene. It will be recessed .38" and will be welded to the tank sides and the longitudinal partitions.

Tank top will be sufficiently supported to keep it rigid during fast filling conditions.

Construction will include 2.00" polypropylene dowels spaced no more than 30.00" apart and welded to the transverse partitions. Two (2) of the dowels will be drilled and tapped (.50" diameter, 13.00" deep) to accommodate lifting eyes.

A sump that will be sized dependent on the tank to pump plumbing will be provided at the bottom of the water tank.

Sump will include a drain plug and the tank outlet.

Tank will be installed in a fabricated cradle assembly constructed of structural steel.

Sufficient crossmembers will be provided to properly support bottom of tank. Crossmembers will be constructed of steel bar channel or rectangular tubing.

Tank will "float" in cradle to avoid torsional stress caused by chassis frame flexing. Rubber cushions, .50" thick x 3.00" wide, will be placed on all horizontal surfaces that the tank rests on.

Stops or other provision will be provided to prevent an empty tank from bouncing excessively while moving vehicle.

Mounting system will be approved by the tank manufacturer.

Fill tower will be constructed of .50" polypropylene and will be a minimum of 8.00" wide x 14.00" long.

Fill tower will be furnished with a .25" thick polypropylene screen and a hinged cover.

An overflow pipe, constructed of 4.00" schedule 40 polypropylene, will be installed approximately halfway down the fill tower and extend through the water tank and exit to the rear of the rear axle.

two (2) notch(es) will be provided in the poly water tank for both the foam pump and the generator, see drawing .

SLEEVE, PLUMBING, THROUGH TANK

One (1) sleeve will be provided in the water tank for a 3.00" pipe to the rear.

WATER TANK RESTRAINT

A heavy-duty water tank restraint will be provided.

HOSE BED

The hose bed will be fabricated of 0.125"-5052 aluminum with a nominal 38,000 psi tensile strength.

The hose bed will be as low as practical.

Upper and rear edges of side panels will have a double break for rigidity.

Any area of the outboard hose bed wall that extends past the end of the hose bed floor will be covered with brushed stainless steel to prevent damage to painted surface when hose is removed.

Flooring of the hose bed will be removable aluminum grating with the top surface corrugated to aid in hose aeration. The grating slats will be a minimum of 0.50" x 4.50" with spacing between slats for hose ventilation.

A cross divider will be provided at the front of the hose bed before the tank transitions from the lower section to the upper section. The divider will run from the top of the side sheet down below the hose bed grating.

The hose bed floor will be 68" from the ground when the truck is fully loaded.

The hose bed interior walls will be painted to match the lower body color.

Hose bed will accommodate Left to right, #1: 400' of 3" DJ #2: 400' of 3" DJ #3: 1000' of 5" #4: 250' of 2.5" DJ #5: 200' of 1.75" DJ Single Stack .

HOSE BED DIVIDER

Four (4) hosebed dividers will be furnished for separating hose.

Each divider will be constructed of a .25" brushed aluminum sheet. Flat surfaces will be sanded for uniform appearance, or constructed of brushed aluminum.

Divider will be fully adjustable by sliding in tracks, located at the front and rear of the hose bed.

Divider will be held in place by tightening bolts, at each end.

Acorn nuts will be installed on all bolts in the hose bed which have exposed threads.

A cross-divider will be provided just behind the fill tower. The divider will be bolted to the side sheet.

CUTOUT, HANDHOLD

A cutout with radiused corners will be provided at the rear of the four (4) hose bed divider(s).

REINFORCED HOSEBED FLOOR

A reinforced hosebed floor will be provided above the water tank to support the mounting of a generator at the front of the hosebed. Aluminum treadplate will cover the floor.

HOSE BED COVER

A two (2) section hose bed cover, constructed of .125" bright aluminum treadplate, will be furnished. The cover will be hinged with full length stainless steel piano hinge. The sides will be slanted down.

The cover will be reinforced so that it can support the weight of a man walking on the cover.

The cover is designed with the left cover opening first.

The cover will not have separate access to the water tank fill tower or foam tank fill tower(s) if so equipped. The covers will have to be raised to access the fill tower(s).

Chrome grab handles and four (4) gas filled cylinders will be provided to assist in opening and closing the cover. A handrail is provided at the rear, in the center of the support, to assist in opening the cover.

The hose bed cover will be connected to the Do Not Move Truck indicator. The light will be activated if the cover is not in the stowed position and the parking brake is released.

A red vinyl flap will be installed on the rear of the bright aluminum treadplate hose bed cover with quarter turn fasteners. A chain weight and paddle seat belt buckles will be provided at the bottom of the cover.

RUNNING BOARDS

Running boards will be fabricated of .125" bright aluminum treadplate.

Each running board will be supported by a welded 2.00" square tubing and channel assembly which will be bolted to the pump compartment substructure.

Running boards will be 14.75" deep and spaced .50" away from the pump panel.

A splash guard will be provided below the running board treadplate.

TAILBOARD

The tailboard will also be constructed of .125" bright aluminum treadplate and spaced .50" from the body, as well as supported by a structural steel assembly.

The tailboard area will be 24.00" deep in the center area and 8.00" deep to the rear of the side compartments. The tailboard will be T-shaped. The outboard sides of the tailboard will be angled at 45 degrees beginning at the point where the body meets the tailboard at the outboard edge angling rearward to the rear edge of the tailboard.

The exterior side will be flanged down and in for increased rigidity of tailboard structure.

REAR WALL, SMOOTH ALUMINUM/BODY MATERIAL

The rear facing surfaces of the center rear wall will be smooth aluminum.

The bulkheads, the surface to the rear of the side body compartments, will be smooth and the same material as the body.

Any inboard facing surfaces below the height of the hosebed will be aluminum diamondplate.

REAR TOW EYES

Two (2) tow eyes, which are an integral part of the body mounting substructure, will be installed below the rear of the truck.

The tow eyes will be of adequate strength to allow the truck to be pulled from the eyes.

REAR HITCH RECEIVER

One (1) hitch receiver will be installed below the tailboard at the rear of the apparatus.

The hitch will be constructed of high strength steel and reinforced to the truck framework, via the rear body substructure. The hitch receiver will have an SAE J684 Class IV rating of 10,000 lb towing and 1000 lb tongue weight.

Slide-in portion will be held in place by one (1) safety pin with clip.

The trailer electrical connection will be a no electric connection.

RUNNING BOARD HOSE RESTRAINT

A pair of 2.00" wide black nylon straps with Velcro fasteners will be provided for each hose tray to secure the hose during travel. There will be Two (2) hose trays located one (1) in each side running board.

RUNNING BOARD HOSE RESTRAINT

A pair of 2.00" wide black nylon straps with Velcro fasteners will be provided for each hose tray to secure the hose during travel. There will be One (1) hose tray located in the right side running board. The straps will be mounted for water can TBD.

HOSE TRAY

There will be Two (2) hose trays free floating hose tray to fit in the opening of the running board will be provided one (1) in each side running board. The tray will be flanged and drop in from the top.

Capacity of the tray will be 25' of 5" LDH driver side, 50' of 2.5" DJ on officer side.

Rubber matting will be installed on the floor of the tray to provide proper ventilation. Drain holes will be provided.

EXTINGUISHER BIN IN HOSE TRAY

There will be a quantity of one (1) circular recessed extinguisher bin(s) provided officer side running board forward in the running board(s).

The bin(s) will be 8.00" in diameter and 8.00" deep. Footman loops and Velcro® straps will be provided for each bin to restrain the extinguisher.

COMPARTMENTATION

Body and compartments will be fabricated of 0.125", 5052-H32 aluminum.

Side compartments will be an integral assembly with the rear fenders.

Circular fender liners will be provided for prevention of rust pockets and ease of maintenance.

Side compartment flooring will be of the sweep out design with the floor higher than the compartment door lip.

The side compartment door opening will be framed by flanging the edges in 1.75" and bending out again 0.75" to form an angle.

Drip protection will be provided above the doors by means of bright aluminum extrusion, formed bright aluminum treadplate or polished stainless steel.

The top of the compartment will be covered with bright aluminum treadplate rolled over the edges on the front, rear and outward side. These covers will have the corners welded.

Side compartment covers will be separate from the compartment tops.

Front facing compartment walls will be covered with bright aluminum treadplate.

All screws and bolts which protrude into a compartment will have acorn nuts on the ends to prevent injury.

UNDERBODY SUPPORT SYSTEM

Due to the severe loading requirements of this pumper a method of body and compartment support suitable for the intended load will be provided.

The backbone of the support system will be the chassis frame rails which is the strongest component of the chassis and is designed for sustaining maximum loads.

Forward to the rear axle, the support system will include "L"-shaped support members bolted to the chassis frame rails. These welded support members will include vertical formed channels, horizontal structural channels, and support gussets. These parts extend from the chassis frame outward underneath the body.

Rearward to the rear axle, the body support system will include two rearward facing "L"-shaped support members bolted to the chassis frame rails. These support members will be connected to the two body supporting crossmembers forming a boxed foundation for the rear body support system.

Steel upper platform decks will be mounted on the top of these support members to create a floating substructure which will result in a 500 lb equipment support rating per lower compartment.

All structural components of this system will be made from high strength 50K steel plate material or structural steel componentry. The steel frames as well as the steel vertical angles will be treated with an epoxy E-coat to provide resistance to corrosion and chemicals as standard.

The floating substructure will be separated from the horizontal members with neoprene elastomer isolators. These isolators will reduce the natural flex stress of the chassis from being transmitted to the body.

Isolators will have a broad load range, proven viability in vehicular applications, be of a fail-safe design and allow for all necessary movement in three (3) transitional and rotational modes.

The neoprene isolators will be installed in a pattern which assimilates a three (3)-point mounting pattern to reduce the natural flex of the chassis being transmitted to the body.

A design with body compartments hanging on the chassis in an unsupported fashion will not be acceptable.

AGGRESSIVE WALKING SURFACE

All exterior surfaces designated as stepping, standing, and walking areas will comply with the required average slip resistance of the current NFPA standards.

LOUVERS

Louvers will be stamped into compartment walls to provide the proper airflow inside the body compartments and to prevent water from dripping into the compartment. Where these louvers are provided, they will be formed into the metal and not added to the compartment as a separate plate.

TESTING OF BODY DESIGN

Body structural analysis will be fully tested. Proven engineering and test techniques such as finite element analysis, strain gauging, and model analysis will be performed with special attention given to fatigue, life and structural integrity of the body and substructure.

Body will be tested while loaded to its greatest in-service weight.

The criteria used during the testing procedure will include:

- Raising opposite corners of the vehicle tires 9.00" to simulate the twisting a truck may experience when driving over a curb.
- Making a 90 degree turn, while driving at 20 mph to simulate aggressive driving conditions.
- Driving the vehicle at 35 mph on a washboard road.
- Driving the vehicle at 55 mph on a smooth road.
- Accelerating the vehicle fully, until reaching the approximate speed of 45 mph on rough pavement.

Evidence of actual testing techniques will be made available upon request.

LEFT SIDE COMPARTMENTATION

The left side compartmentation will consist of three rollup door compartments.

A full height, rollup door compartment ahead of the rear wheels will be provided. The interior dimensions of this compartment will be 34.50" wide x 66.63" high x 25.88" deep in the lower 25.00" of the compartment and 12.00" deep in the remaining upper portion. The clear door opening will be a minimum of 28.75" wide x 56.88" high.

A rollup door compartment over the rear wheels will be provided. The interior dimensions of this compartment will be 66.50" wide x 32.88" high x 12.00" deep. The clear door opening will be a minimum of 58.25" wide x 23.13" high.

A full height, rollup door compartment behind the rear wheels will be provided. The interior dimensions of this compartment will be 47.75" wide x 61.63" high x 25.88" deep in the lower 20.00" of height and 12.00" deep in the remaining upper section of the compartment. The clear door opening will be a minimum of 44.75" wide x 51.88" high.

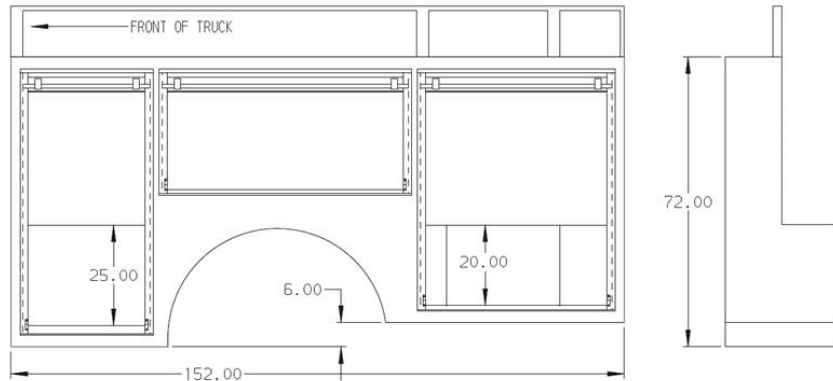

COMPARTMENT	CLEAR DOOR OPENINGS					
	AMDOR		GORTITE		ROM	
	HORIZONTAL	VERTICAL	HORIZONTAL	VERTICAL	HORIZONTAL	VERTICAL
Ahead of axle	29.50	56.88	28.75	58.00	28.94	58.25
Over axle	59.00	23.13	58.25	24.25	58.44	24.50
Behind axle	45.50	51.88	44.75	53.00	44.94	53.25

The interior height of the compartments will be measured from the compartment floor to the ceiling. The spool of the rollup door at the top of the compartment takes up some usable space. The depth of the compartments will be measured from the back wall to the inside of the door frame.

Closing of the door will not require releasing, unlocking, or unlatching any mechanism and will easily be accomplished with one hand.

RIGHT SIDE COMPARTMENTATION

The right side compartmentation will consist of three compartments.

A rollup door compartment ahead of the rear wheels will be provided. The interior dimensions of this compartment will be 34.50" wide x 46.13" high x 25.88" deep in the lower 25.00" of the compartment and 12.00" deep in the remaining upper portion. The clear door opening will be a minimum of 28.75" wide x 36.38" high.

A horizontally hinged, drop-down door compartment over the rear wheels will be provided. The interior dimensions of this compartment will be 66.50" wide x 12.38" high x 12.00" deep. The clear door opening will be a minimum of 59.25" wide x 6.63" high.

A rollup door compartment behind the rear wheels will be provided. The interior dimensions of this compartment will be 47.75" wide x 41.13" high x 25.88" deep in the lower 20.00" of the compartment and 12.00" deep in the remaining upper portion. The clear door opening will be a minimum of 44.75" wide x 31.38" high.

The interior height of the compartments will be measured from the compartment floor to the ceiling. The spool of the rollup door at the top of the compartment takes up some usable space. The depth of the compartments will be measured from the back wall to the inside of the door frame.

Closing of the doors will not require releasing, unlocking, or unlatching any mechanism and will easily be accomplished with one hand.

The drop-down door will be furnished with two chain-style door holders with a plastic covering around the chain.

SIDE COMPARTMENT ROLLUP DOOR(S)

There will be five (5) compartment doors installed on the side compartments. The doors will be double faced aluminum construction, painted one (1) color to match the lower portion of the body and manufactured by Gortite®.

Lath sections will be an interlocking rib design and will be individually replaceable without complete disassembly of door.

Between each slat at the pivoting joint will be a PVC inner seal to prevent metal to metal contact and prevent dirt or moisture from entering the compartments. Seals will allow door to operate in extreme temperatures ranging from 180 to -40 degrees Fahrenheit. Side, top and bottom seals will be provided to resist ingress of dirt and weather and be made of Santoprene.

All hinges, barrel clips and end pieces will be nylon 66. All nylon components will withstand temperatures from 300 to -40 degrees Fahrenheit.

A polished stainless steel lift bar to be provided for each roll-up door. Lift bar will be located at the bottom of door and have latches on the outer extrusion of the doors frame. A ledge will be supplied over lift bar for additional area to aid in closing the door.

Doors will be constructed from an aluminum box section. The exterior surface of each slat will be flat. The interior surfaces will be concave to provide strength and prevent loose equipment from jamming the door from inside.

To conserve space in the compartments, the spring roller assembly will not exceed 3.00" in diameter.

The header for the rollup door assembly will not exceed 4.00".

A heavy-duty magnetic switch will be used for control of open compartment door warning lights.

REAR COMPARTMENTATION

A roll-up door compartment above the rear tailboard will be provided.

The interior dimensions of this compartment will be 40.00" wide x 33.63" high x 25.88" deep. The spool of the rollup door at the top of the compartment takes up some usable space. The depth of the compartment will be calculated with the compartment door closed.

A louvered, removable access panel will be furnished on the back wall of the compartment.

The rear compartment will be open into the rear side compartments.

The clear door opening of this compartment will be a minimum of 33.25" wide x 23.88" high.

Closing of the door will not require releasing, unlocking, or unlatching any mechanism and will easily be accomplished with one hand.

ROLLUP REAR COMPARTMENT DOOR

There will be a rear rollup door. The door will be double faced aluminum construction, painted one (1) color to match the lower portion of the body and manufactured by Gortite®.

Lath sections will be an interlocking rib design and will be individually replaceable without complete disassembly of door.

Between each slat at the pivoting joint will be a PVC inner seal to prevent metal to metal contact and prevent dirt or moisture from entering the compartments. Seals will allow door to operate in extreme temperatures ranging from 180 to -40 degrees Fahrenheit. Side, top and bottom seals will be provided to resist ingress of dirt and weather and be made of Santoprene.

All hinges, barrel clips and end pieces will be nylon 66. All nylon components will withstand temperatures from 300 to -40 degrees Fahrenheit.

A polished stainless steel lift bar to be provided for each roll-up door. Lift bar will be located at the bottom of door and have latches on the outer extrusion of the doors frame. A ledge will be supplied over lift bar for additional area to aid in closing the door.

Door will be constructed from an aluminum box section. The exterior surface of each slat will be flat. The interior surface will be concave to provide strength and prevent loose equipment from jamming the door from inside.

To conserve space in the compartments, the spring roller assembly will not exceed 3.00" in diameter.

The header for the rollup door assembly will not exceed 4.00".

A heavy-duty magnetic switch will be used for control of open compartment door warning lights.

PULL STRAP, DOORS

There will be three (3) compartment doors provided with pull straps on the following compartment doors:LS1, LS2 and LS3

SCUFFPLATE

Two (2) scuffplates, of brushed stainless steel will be provided on the rear of the body under pike pole heads on rear bulkhead officer to protect from pike heads TBD.

DOOR GUARD

six (6) compartment doors will include an L-shaped guard designed to protect the bottom and interior side of the roll-up door from damage when in the retracted position and contain any water spray while the door is being opened. The guard will be fabricated from stainless steel and installed all roll up compartment doors.

ROLL-UP DOOR TRIM

The exterior of the aluminum trim around the door opening will be painted job color.

There will be six (6) compartments with the trim painted.

COMPARTMENT LIGHTING

There will be seven (7) compartment(s) with two (2) white 12 volt DC LED compartment light strips. The dual light strips will be centered vertically along each side of the door framing. There will be two (2) light strips per compartment. The dual light strips will be in all body compartment(s).

Any remaining compartments without light strips will have a 6.00" diameter Truck-Lite, Model: 79384 light. Each light will have a number 1076 one filament, two wire bulb.

Opening the compartment door will automatically turn the compartment lighting on.

MOUNTING TRACKS

There will be five (5) sets of tracks for mounting shelf(s) in LS1, LS2, LS3, RS1 and RS3. These tracks will be installed vertically to support the adjustable shelf(s). The tracks will be unpainted with a natural finish.

ADJUSTABLE SHELVES

There will be eight (8) shelves with a capacity of 500 lb provided.

The shelf construction will consist of .188" aluminum painted spatter gray with 2.00" sides.

Each shelf will be infinitely adjustable by means of a threaded fastener, which slides in a track.

The shelves will be held in place by .12" thick stamped plated brackets and bolts.

The location(s) will be determined at a later date.

SLIDE-OUT FLOOR MOUNTED TRAY

There will be two (2) floor mounted slide-out tray(s) provided.

Each tray will have 2.00" high sides and a minimum capacity rating of 500 lb in the extended position.

Each tray will be constructed of aluminum painted spatter gray

There will be two undermount-roller bearing type slides rated at 250lb each provided. The pair of slides will have a safety factor rating of 2.

To ensure years of dependable service, the slides will be coated with a finish that is tested to withstand a minimum of 1,000 hours of salt spray per ASTM B117.

To ensure years of easy operation, the slides will require no more than a 50lb force for push-in or pull-out movement when fully loaded after having been subjected to a 40 hour vibration (shaker) test under full load. The vibration drive file will have been generated from accelerometer data collected from a heavy truck chassis driven over rough gravel roads in an unloaded condition. Proof of compliance will be provided upon request.

Automatic locks will be provided for both the "in" and "out" positions. The trip mechanism for the locks will be located at the front of the tray for ease of use with a gloved hand.

The location(s) will be LS1 and B1.

PARTITION, TRANSVERSE REAR COMPARTMENT

Two (2) partitions will be bolted in place to separate the left and right side rear compartments from the rear tailboard compartment. The partition will be body material painted spatter gray.

MOUNTING PLATE

A quantity of two (2) 3/16" thick aluminum mounting plate(s) will be provided. The aluminum plate(s) will be painted spatter gray to match compartment interior. The plate(s) will be entire back wall of each compartment in size and mounted in LS2 back wall and RS2 back wall .

MATTING, COMPARTMENT FLOOR

Turtle Tile compartment matting will be provided in five (5) compartments on the compartment floor. The locations are, LS2, LS3, RS1, RS2, RS3.

The Turtle Tile will be black and the leading edge of the matting will include the beveled edge. The beveled edge will be black .

MATTING, COMPARTMENT SHELVING

Turtle Tile compartment matting will be provided in ten (10) shelves. The locations are, all shelves and trays.

The color of the Turtle Tile will be black.

RUB RAIL

Bottom edge of the side compartments will be trimmed with a bright aluminum extruded rub rail.

Trim will be 2.12" high with 1.38" flanges turned outward for rigidity.

The rub rails will not be an integral part of the body construction, which allows replacement in the event of damage.

BODY FENDER CROWNS

Black rubber fender crowns will be provided around the rear wheel openings.

BODY FENDER LINER

An unpainted brushed stainless fender liner will be provided. The liners will be removable to aid in the maintenance of rear suspension components.

HARD SUCTION HOSE

Two (2) lengths of Kochek 5.00" clear corrugated PVC hard suction hose, 10' in length, will be provided by Front Range Fire Apparatus. The hose will be equipped with a long handle female coupling on one (1) end and a rocker lug male coupling on the other end. Couplings will be hard coated aluminum.

HARD SUCTION HOSE COMPARTMENT

A quantity of one (1) enclosed hard suction hose compartment(s) will be provided on the left side above the body compartments and capable of storing two (2) hard suction hoses. The compartment will run the full length of the body.

A quantity of two (2) hard suction hoses will be carried in aluminum troughs, mounted one (1) above the other inside the compartment.

The compartment will be fabricated of the same material as the body with the exterior painted, and aluminum treadplate surface on top of the compartment..

One (1) smooth aluminum door with a D-handle latch hinged on the left side, will be provided at the rear of the compartment.

HANDRAILS

The handrails will be 1.25" diameter knurled aluminum to provide a positive gripping surface.

Chrome plated end stanchions will support the handrail. Plastic gaskets will be used between end stanchions and any painted surfaces.

Drain holes will be provided in the bottom of all vertically mounted handrails.

Handrails will be provided to meet NFPA 1901 section 15.8 requirements. The handrails will be installed as noted on the sales drawing.

HANDRAILS

One (1) vertical handrail will be located on each rear beavertail.

- One (1) handrail will be installed below the hose bed mounted to the underside of the rear step.

EXTINGUISHER/AIR BOTTLE/ STORAGE (TRIANGULAR)

A total of one (1) extinguisher/air bottle/storage compartments will be provided Passenger side forward. The triangular shaped compartment will be sized to fit a 8.00" diameter extinguisher in the lower area and a 8.00" diameter extinguisher in the upper area. The compartment will be approximately 25.50" deep. A partition will be provided to separate the compartment. Also inside the compartment, black rubber matting will be provided. The compartment will be furnished with a drain hole. A brushed stainless steel, triangular shaped door with a Southco raised trigger C2 chrome lever latch will be provided to contain the air bottles. A dielectric barrier will be provided between the door hinge, hinge fasteners and the body sheet metal.

AIR BOTTLE COMPARTMENT STRAP

A strap will be provided in the air bottle compartment(s) to help contain the bottles when the vehicle is parked on an incline. The strap will wrap around the neck and attach to the wall of the compartment.

AIR BOTTLE STORAGE (DOUBLE)

A quantity of two (2) air bottle compartments, 15.25" wide x 7.75" tall x 26.00" deep, will be provided on the left side forward of the rear wheels. The triangular door shall cover the double air bottle opening and the DEF tank access. and on the left side rearward of the rear wheels. The triangular door shall

cover the double air bottle opening and the fuel tank access.. A brushed stainless steel door with a Southco raised trigger C2 chrome lever latch will be provided to contain the air bottle. A dielectric barrier will be provided between the door hinge, hinge fasteners and the body sheet metal.

Inside the compartment, "W" shaped insert formed of composite materials will be provided.

AIR BOTTLE COMPARTMENT STRAP

A strap will be provided in the air bottle compartment to help contain the air bottle when the vehicle is parked on an incline. The strap will wrap around the neck and attach to the wall of the compartment.

AIR BOTTLE STORAGE (TRIPLE)

A quantity of one (1) air bottle compartment designed to hold (3) air bottles up to 7.25" in diameter x 26.00" deep will be provided on the right side rearward of the rear wheels. A brushed stainless steel door with a Southco raised trigger C2 chrome lever latch will be provided to contain the air bottle. A dielectric barrier will be provided between the door hinge, hinge fasteners and the body sheet metal.

Inside the compartment, black rubber matting will be provided.

AIR BOTTLE COMPARTMENT STRAP

A strap will be provided in the air bottle compartment(s) to help contain the air bottles when the vehicle is parked on an incline. The strap will wrap around the neck and attach to the wall of the compartment.

EXTENSION LADDER

There will be a 24', two (2) section, aluminum, Duo-Safety, Series 900-A extension ladder provided.

ROOF LADDER

There will be one (1) 14' aluminum, Duo-Safety, Series 775-DR roof ladder(s) provided. The ladder(s) will have roof hooks on both ends.

LADDER RACK

There will be a quantity of two (2) ground ladders mounted above right side of body compartments to a vertical surface in a Zico Quic-Lift electric ladder lowering system. The ladder rack mounts will be powered by two (2), 12-volt electric actuators.

The electric controls will be located at the pump panel or in such a manner to allow the operator full view of the area in which the ladders will be lowered.

The electric actuator control will have a master switch and be interlocked to prevent operation should a compartment door, in the travel area of the ladder bracket, be in the open position.

LADDER RACK INTERLOCK AND NOT STOWED INDICATOR LIGHT

An interlock will be provided to prevent operation of the ladder rack unless the apparatus parking brake has been activated.

A steady red indicator light will be located on the cab instrument panel and illuminated when the hydraulic ladder rack is not in the stowed position. The light will be labeled "Ladder Rack". In addition, the "Do Not Move Apparatus" light located in the cab will be activated when the hydraulic ladder rack is not in the stowed position.

LIGHTS, FLASHING, HYD LADDER RACK

Flashing amber lights facing the front and rear will be provided on the ladder rack and activated whenever the rack is in the down position.

LADDER STORAGE, FOLDING LADDER

Mounting provisions will be provided to store a 10' folding ladder on the hydraulic ladder rack.

FOLDING LADDER

One (1) 10' aluminum, Series 585-A Duo-Safety folding ladder will be installed [Location, Fold Ladder].

4' PIKE POLE

One (1) pike pole, Fire Hooks Unlimited, Model RH 4, 4' long roof hook, with a steel handle and pry end will be provided and located on back of cab.

8' PIKE POLE

One (1) pike pole, Fire Hooks Unlimited, Model RH 8, 8' long roof hook, with a steel handle and pry end will be provided and located in tube on top of officer side body .

8' COLORADO HOOK PIKE POLE

One (1) pike pole will be provided TBD. The pole(s) will be Fire Hooks Unlimited Colorado hook(s), 10' with an arson-trash hook on one end and a all-purpose hook on the opposite end with a steel shaft

- one (1) Fire Hooks Unlimited, New York Roof Hook , 10' long roof hook with steel shaft and pry end will be provided.

6 FT PIKE POLE

There will be two (2) Fire Hooks Unlimited NY roof hook RH-6, 6 foot pike pole(s) with steel handles and pry end provided back of cab mounting, in tube on top of officer side body.

PIKE POLE STORAGE

Aluminum tubing will be used for the storage of three (3) pike poles and will be located on top of officer side body. If the head of a pike pole can come in contact with a painted surface, a stainless steel scuffplate will be provided. The pike pole tube will be notched to allow a New York style pike pole to fit into the tube.

PIKE POLE MOUNTING

A total of two (2) set(s) of Fire Hooks Unlimited, model Hooks Nest 4 and PAC Handlelok, model 1004, mounting brackets will be provided for the mounting of Fire Hooks Unlimited pike poles. The Hooks Nest 4 head bracket will be used to secure the upper portion of the pike pole in conjunction with the Handlelok to secure the handle of the pike pole. The lower pinned portion of the Nest 4 bracket will be shipped with loose equipment. The brackets will be installed back of cab each side (set for 4' NY, so they can store a 4' or a 6') .

PIKE POLE STORAGE

There will be two (2) PAC, Handlelok Model 1004, pike pole mounting bracket(s) used for pike pole storage and located top of driver side body (for CO Hook).

FOLDING STEPS FRONT OF BODY

Folding steps will be provided full height on the left side body compartments to provide access to the cargo bed. Steps will be spaced evenly on the sales drawing. Actual quantity may vary due to pump panel interferences but will meet the NFPA required maximum stepping height.

The Trident steps will be bright finished, non-skid with a black tread coating on the stepping surface.

The step will incorporate an LED light to illuminate the stepping surface.

The steps can be used as a hand hold with two openings wide enough for a gloved hand.

REAR FOLDING STEPS

Bright finished, non-skid folding steps with a black tread coating on the stepping surface will be provided at the rear. Each step will incorporate an LED light to illuminate the stepping surface. The steps can be used as a hand hold with two openings wide enough for a gloved hand.

STEP, PULL-OUT/DROP DOWN

Two (2) pull-out steps will be provided. Each step will be 26" wide x 8.00" deep and will pull out and drop down to provide easy access.

A pullout and down (camper style) step will be installed below the body. The step surface, when pulled out from its nested position, will be 9.00" below the body. The stepping surface will be bright aluminum treadplate.

The step will be located on the rear bumper.

I-ZONE BRACKETS - WILDLAND STYLE

A pair of I-Zone brackets will be provided and mounted at the rear of the apparatus, (1) each side on the rear of the body as shown on the AD. The brackets will be designed with adequate reinforcement to eliminate flexing of the body (oil canning) and not interfere with rear facing lights while carrying hose.

The design of these I-Zone brackets will have a 45 degree receiver and a removable extension piece that fits into the brackets for carrying hose.

An 8.00" deep bright aluminum treadplate step will be provided at the rear of the body above the rear compartment.

PUMP COMPARTMENT

The pump compartment will be separate from the hose body and compartments so that each may flex independently of the other. The pump compartment will be constructed of the same material as the body compartmentation.

The pump compartment substructure will be a fabricated assembly of steel tubing, angles and channels which supports both the fire pump and the side running boards.

The pump compartment will be mounted on the chassis frame rails with rubber biscuits in a four point pattern to allow for chassis frame twist.

Pump compartment, pump, plumbing and gauge panels will be removable from the chassis in a single assembly.

PUMP MOUNTING

Pump will be mounted to a substructure which will be mounted to the chassis frame rail using rubber isolators. The mounting will allow chassis frame rails to flex independently without damage to the fire pump.

LEFT SIDE PUMP CONTROL PANEL

All pump controls and gauges will be located at the left (driver's) side of the apparatus and properly identified.

Layout of the pump control panel will be ergonomically efficient and systematically organized.

The pump operator's control panel will be removable in two (2) main sections for ease of maintenance:

The upper section will contain sub panels for the mounting of the pump pressure control device, engine monitoring gauges, electrical switches, and foam controls (if applicable). Sub panels will be removable from the face of the pump panel for ease of maintenance. Below the sub panels will be located all valve controls and line pressure gauges.

The lower section of the panel will contain all inlets, outlets, and drains.

All push/pull valve controls will have 1/4 turn locking control rods with polished chrome plated zinc tee handles. Guides for the push/pull control rods will be chrome plated zinc castings securely mounted to the pump panel. Push/pull valve controls will be capable of locking in any position. The control rods will pull straight out of the panel and will be equipped with universal joints to eliminate binding.

IDENTIFICATION TAGS

The identification tag for each valve control will be recessed in the face of the tee handle.

All discharge outlets will have color coded identification tags, with each discharge having its own unique color. Color coding will include the labeling of the outlet and the drain for each corresponding discharge.

All line pressure gauges will be mounted directly above the corresponding discharge control tee handles and recessed within the same chrome plated casting as the rod guide for quick identification. The gauge and rod guide casting will be removable from the face of the pump panel for ease of maintenance. The casting will be color coded to correspond with the discharge identification tag.

All remaining identification tags will be mounted on the pump panel in chrome plated bezels.

The pump panel on the right (passenger's) side will be removable with lift and turn type fasteners.

Trim rings will be installed around all inlets and outlets.

PUMP

Pump will be a Waterous CMPA, 1250 gpm, two (2) stage power take off (PTO) driven, midship mounted centrifugal type.

Pump will be the class "A" type.

Pump will deliver the percentage of rated discharge at pressures indicated below:

- 100% of rated capacity at 150 psi net pump pressure.

-70% of rated capacity at 200 psi net pump pressure.

-50% of rated capacity at 250 psi net pump pressure.

Pump body will be close-grained gray iron, bronze fitted, and will be horizontally split in two (2) sections for easy removal of the entire impeller shaft assembly (including wear rings).

Pump will be designed for complete servicing from the bottom of the truck, without disturbing the pump setting or apparatus piping.

Pump case halves will be bolted together on a single horizontal face to minimize a chance of leakage and facilitate ease of reassembly. No end flanges will be used.

Discharge manifold of the pump will be cast as an integral part of the pump body assembly and will provide a minimum of three (3) 3.50" openings for flexibility in providing various discharge outlets for maximum efficiency.

The three (3) 3.50" openings will be located as follows: one (1) outlet to the right of the pump, one (1) outlet to the left of the pump, and one (1) outlet directly on top of the discharge manifold.

Impeller shaft will be stainless steel accurately ground to size. It will be supported at each end by grease lubricated, anti-friction ball bearings for rigid precise support.

Bearings will be protected from water and sediment by suitable stuffing boxes, flinger rings, and oil seals. No special or sleeve type bearings will be used.

Pump will be equipped with a self-adjusting, maintenance-free, mechanical shaft seal.

The mechanical seal will consist of a flat, highly polished, spring fed carbon ring that rotates with the impeller shaft. The carbon ring will press against a highly polished stainless steel stationary ring that is sealed within the pump body.

In addition, a throttling ring will be pressed into the steel chamber cover, providing a very small clearance around the rotating shaft in the event of a mechanical seal failure. The pump performance will not deteriorate, nor will the pump lose prime, while drafting if the seal fails during pump operation.

Wear rings will be bronze and easily replaceable to restore original pump efficiency and eliminate the need to replace the entire pump casing due to wear.

PUMP TRANSMISSION

The pump transmission will be made of light weight aluminum casing. Power transfer to pump will be through a pressure lubricated, Morse HY-VO drive chain.

Drive shafts will be a minimum of 1.50" diameter hardened and ground alloy steel. All shafts will be ball bearing supported. The case will be designed as to eliminate the need for water cooling.

The water pump will be driven by a special heavy duty ten (10)-bolt hot shift PTO. It will be located on the left side of the chassis transmission. This PTO will be designed specifically for the torque required to drive a 1250 gpm or larger water pump.

PUMPING MODE

An interlock system will be provided to ensure that the pump drive system components are properly engaged so that the apparatus can be safely operated. The interlock system will be designed to allow stationary pumping and the truck to be in motion while pumping.

A digital pump pressure gauge will be supplied in the cab.

PUMP SHIFT

A pump shift will be provided within easy reach of the driver for engagement of the PTO driven pump. The shift will include the indicator lights as mandated by NFPA. The pump shift control will be illuminated to meet NFPA requirements.

AUXILIARY COOLING SYSTEM

A supplementary heat exchange cooling system will be provided to allow the use of water from the discharge side of the pump for cooling the engine water. The heat exchanger will be a separate unit. It will be installed in the pump or engine compartment with the control located on the pump operator's control panel. The exchanger will be plumbed to the master drain valve.

TRANSFER VALVE

Transfer valve design will be of the latest ball type, of all bronze construction incorporating a hydraulically balanced seal assembly, minimizing leakage around the ball and assuring maximum pump efficiency.

Transfer valve will operate smoothly and without sticking, even when exposed to sandy or dirty water.

Transfer valve will be operated manually by means of a handwheel control at the left side pump panel.

Transfer valve will have the ability to change from series (pressure) operation to parallel (volume) operation without reducing the operating speed of the engine regardless of the operating pressure at the pump, thus maintaining an effective fire stream at the nozzle at all times.

INTAKE RELIEF VALVE

One (1) Trident Air Max intake relief valve(s) will be installed on the suction side of the pump preset at 125 psig.

The relief valve will have a working range of 50 PSI to 350 PSI.

The outlet will terminate below the frame rails with a 2.50" National Standard hose thread adapter and will have a "do not cap" warning tag.

One (1) adjustable air regulator and pressure indicating gauge will be located on a common bezel behind the right side pump panel with a stainless steel access door to control the intake valve(s).

PIERCE PRESSURE CONTROLLER

A Pierce electronic pressure controller will be provided.

A pressure transducer will be installed in the discharge side of the water pump. The transducer continuously monitors pump pressure sending a signal to the electronic pressure controller.

The pressure controller can be used in two (2) modes of operation, RPM mode and pressure modes. The controller will be programmed to turn on/default to Pressure Setting mode.

In the RPM mode, the controller can be activated after vehicle parking brake has been set. When in this mode, the controller will maintain the set engine speed, regardless of engine load (within engine operation capabilities).

In the pressure mode, the controller can be activated after vehicle parking brake has been set. When in this mode, the controller will automatically maintain the discharge pressure set by the operator (within the discharge capabilities of the pump and water supply) regardless of flow.

A 2.00" diameter throttle control knob with no mechanical stops, a serrated grip, and a red idle push button in the center will be a integrated/part of the pressure controller. The throttle control knob will be programmed for Clockwise rotation to increase engine speed.

Individual LED indicators for ok to pump, throttle ready, pressure mode and rpm mode will be located on the pressure controller for easy viewing.

A pump cavitation protection feature will also provided which will return the engine to idle should the pump cavitate. Cavitation is sensed by the combination of pump pressure below 30 psi and engine speed above 2000 rpm for more than five (5) seconds.

Other safety features include recognition of low water and no water conditions with an automatic programmed response and a push button to return the engine to idle.

The pressure controller LCD screen will be 4.20" in size with a minimum brightness of 750 nits. The LCD screen and LED intensity will be automatically adjust for day and nighttime operation. The LCD screen intensity can also be manually adjusted if needed.

The following information will be provided/displayed on the LCD screen -

- Engine RPM
- Check engine and stop engine warning indicators
- Engine oil pressure
- Engine coolant temperature
- Water pump temperature
- Fuel Level
- Water tank level

- Battery voltage
- Operating mode (RPM or pressure)
- Pressure or RPM setting

On screen messaging show diagnostic and warning messages as they occur. It will show apparatus information, stored data, and program options when selected by the operator. It will monitor inputs outputs and support audible and visual warning alarms for the following conditions -

- High battery voltage
- Low battery voltage/engine off
- Low battery voltage/engine running
- High water pump temperature
- Low fuel
- Low engine oil pressure
- High engine coolant temperature
- Water tank out of water (visual alarm only)
- No engine response (visual alarm only)

The pressure controller will store the accumulated operating hours for the pump and engine. These items are to be displayed within the pressure controller menu.

The pressure controller will include a USB port on the back of the controller for easy software upgrades if needed.

All of the read outs at the pump panel will be in metric.

PRIMING PUMP

The priming pump will be a Trident Emergency Products compressed air powered, high efficiency, multi-stage venturi based AirPrime System, conforming to standards outlined in NFPA pamphlet #1901.

All wetted metallic parts of the priming system are to be of brass and stainless steel construction.

One (1) priming control will open the priming valve and start the pump primer.

Two (2) additional priming valves will be plumbed to the the left and right side main inlets. The additional push button controls will be located at the pump operator's panel.

AIR BLOWOUT VALVE

A blowout will be furnished to blow out any remaining water from the pump or individual discharge lines.

Blowout will be piped from the wet tank of the brake system to the main body of the pump, and will be controlled at the pump operator's panel.

RECIRCULATING LINE WITH CHECK VALVE

A 0.50" diameter recirculating line, from the pump to the water tank, will be furnished with a control installed at the pump operator's control panel. A check valve will be provided in this line to prevent the back flow of water from the tank to the pump if the valve is left in the open position.

THERMAL RELIEF VALVE

A Waterous Overheat Protection Manager (OPM) will be included on the pump that monitors pump water temperature and opens to relieve water to cool the pump when the temperature of the pump water exceeds 140 Degrees F (60 C) and a red warning light that is triggered when the water in the pump reaches 180 F (82 C).

The warning light will act as an additional protection device if the temperature in the pump keeps rising after the valve opens. The warning light with a test switch will be mounted on the pump operator panel.

The discharge line will be plumbed to ground.

PUMP MANUALS

There will be a total of two (2) pump manuals provided by the pump manufacturer and furnished with the apparatus. The manuals will be provided by the pump manufacturer in the form of two (2) electronic copies. Each manual will cover pump operation, maintenance, and parts.

PUMP TEST

The pump will be tested, approved and certified by an independent third party testing agency at the manufacturer's expense. The test results along with the pump manufacturer's certification of hydrostatic test, the engine manufacturer's certified brake horse power curve and the manufacturer's record of pump construction details will be forwarded to the Fire Department.

The pump test will be performed for 1250 GPM at 8250'.

PLUMBING, STAINLESS STEEL AND HOSE

All inlet and outlet lines will be plumbed with either stainless steel pipe, hydraulic type hose or synthetic rubber hose reinforced with hi-tensile polyester braid. All hose's will be equipped with brass or stainless steel couplings. All stainless steel hard plumbing will be a minimum of a schedule 10 wall thickness.

Where vibration or chassis flexing may damage or loosen piping or where a coupling is required for servicing, the piping will be equipped with victaulic or rubber couplings.

Plumbing manifold bodies will be ductile cast iron or stainless steel.

All piping lines are to be drained through a master drain valve or will be equipped with individual drain valves. All drain lines will be extended with a hose to drain below the chassis frame.

All water carrying gauge lines will be hydraulic or reinforced poly hose.

All piping, hose and fittings will have a minimum of a 700 PSI hydrodynamic pressure rating.

FOAM SYSTEM PLUMBING

All piping that is in contact with the foam concentrate or foam/water solution will be stainless steel. The fittings will be stainless steel or brass. Cast iron pump manifolds will be allowed.

MAIN PUMP INLETS

A 6.00" pump manifold inlet will be provided on each side of the vehicle. The suction inlets will include removable die cast zinc screens that are designed to provide cathodic protection for the pump, thus reducing corrosion in the pump.

INLET BUTTERFLY VALVE

There will be one (1) butterfly valve provided on the left side main pump inlet.

The 6.00" Jamesbury inlet valve will be recessed behind the pump panel with a stainless steel trim ring around the opening.

A built-in, adjustable pressure relief valve and a bleeder valve will be provided on the inlet side of the valve.

There will be an Akron 9333 electric valve controller provided on the pump operators panel. The electric control must be of a true position feedback design, requiring no clutches in the motor or current limiting. The unit must be completely sealed with momentary open, close as well and an optional one touch full open feature to operate the valve actuator. The controller will provide position indication on a full color, backlit LCD display. It will have manual adjustment of the brightness as well as an auto dimming option.

The electric actuator will be furnished with a manual override accessible at the pump panel.

A maintain switch will be provided behind the stainless steel access door near the manual override. The switch will cut off power to the valve to allow for manual override valve actuation.

INLET BUTTERFLY VALVE

There will be One (1) butterfly valve provided on the right side main pump inlet(s).

The 6.00" Jamesbury inlet valve will be recessed behind the pump panel with a stainless steel trim ring around the opening.

A built-in, adjustable pressure relief valve and a bleeder valve will be provided on the inlet side of the valve.

There will be Akron 9333 electric valve controller(s) provided on the pump operators panel. The electric control(s) must be of a true position feedback design, requiring no clutches in the motor or current limiting. The unit(s) must be completely sealed with momentary open, close as well and an optional one touch full open feature to operate the valve actuator. The controller(s) will provide position indication on a full color, backlit LCD display. They will have manual adjustment of the brightness as well as an auto dimming option.

The electric actuator will be furnished with a manual override accessible at the pump panel.

A maintain switch will be provided behind the stainless steel access door near the manual override. The switch will cut off power to the valve to allow for manual override valve actuation.

MAIN PUMP INLET CAP PROVIDED BY FIRE DEPARTMENT

NFPA 1901, 2016 edition, section 16.6.8 requires all intakes to be provided with caps or closures capable of withstanding a hydrostatic gauge pressure of 500 psi.

The caps are not on the apparatus as manufactured. The fire department will provide both caps for the main pump inlets.

VALVES

All ball valves will be Akron® Brass. The Akron valves will be the 8000 series heavy-duty style with a stainless steel ball and a simple two-seat design. No lubrication or regular maintenance is required on the valve.

Valves will have a **ten (10) year** warranty.

The location of the valve for the two (2) inlets will be recessed behind the pump panel.

INLET CONTROL

The side auxiliary inlet(s) will incorporate a quarter-turn ball valve with the control located at the inlet valve. The valve operating mechanism will indicate the position of the valve.

LEFT SIDE INLET

There will be one (1) auxiliary inlet with a 2.50" valve at the left side pump panel, terminating with a 2.50" (F) National Standard hose thread adapter.

The auxiliary inlet will be provided with a strainer, chrome swivel and plug.

RIGHT SIDE INLET

There will be one (1) auxiliary inlet with a 2.50" valve at the right side pump panel, terminating with a 2.50" (F) National Standard hose thread adapter.

The auxiliary inlet will be provided with a strainer, chrome swivel and plug.

ANODE, INLET

One (1) pair of sacrificial Zinc anodes will be provided in the water pump to protect the pump from corrosion. One (1) will be placed in the inlet side of the pump and the other one (1) in the discharge side of the pump.

ELBOW, REAR INLET

The inlet, located at the rear of the apparatus, will be furnished with a 6.00" (F) National Standard hose thread x 5.00" Storz 30 degree elbow/adaptor with a Storz cap.

ELBOW, FRONT INLET

The inlet, located at the front of the apparatus, will be furnished with a 6.00" (F) National Standard hose thread x 5.00" Storz 30 degree elbow/adaptor with a Storz cap.

INLET BLEEDER VALVE

A 0.75" bleeder valve will be provided for each side gated inlet.

The valves will be located behind the panel with a "T" swing style handle control extended to the outside of the panel.

The handles will be chrome plated and provide a visual indication of valve position. The swing handle will provide an ergonomic position for operating the valve without twisting the wrist and provides excellent leverage.

The water discharged by the bleeders will be routed below the chassis frame rails.

TANK TO PUMP

The booster tank will be connected to the intake side of the pump with heavy-duty piping and an air actuated quarter turn 4.00" full flow line valve.

The valve will be controlled remotely from the cab and the operator's panel. An indicator light will be provided to show the position of the valve.

The tank to pump line will run straight (no elbows) from the pump into the front face of the water tank and angle down into the tank sump. A rubber coupling will be included in this line to prevent damage from vibration or chassis flexing.

A check valve will be provided in the tank to pump supply line to prevent the possibility of "back filling" the water tank.

TANK REFILL

A 1.50" combination tank refill and pump re-circulation line will be provided, using a quarter-turn full flow ball valve controlled from the pump operator's panel.

DISCHARGE OUTLET CONTROLS

The discharge outlets will incorporate a quarter-turn ball valve with the control located at the pump operator's panel. The valve operating mechanism will indicate the position of the valve.

If a handwheel control valve is used, the control will be a minimum of a 3.9" diameter stainless steel handwheel with a dial position indicator built in to the center of the handwheel.

Any 3.00 inch or larger discharge valve will be a slow-operating valve in accordance with NFPA 16.7.5.3.

LEFT SIDE DISCHARGE OUTLETS

There will be One (1) discharge outlet with a 2.50" valve on the left side of the apparatus, terminating with a 2.50" (M) National Standard hose thread adapter.

LEFT SIDE OUTLET ELBOWS

The 2.50" discharge outlets located on the left side pump panel will be furnished with a 2.50" (F) National Standard hose thread x 2.50" (M) National Standard hose thread, chrome plated, 45 degree elbow.

The elbow will be Pierce VLH, which incorporates an exclusive thread design to automatically relieve stored pressure in the line when disconnected.

RIGHT SIDE DISCHARGE OUTLETS

There will be One (1) discharge outlet with a 2.50" valve on the right side of the apparatus, terminating with a 2.50" (M) National Standard hose thread adapter.

RIGHT SIDE OUTLET ELBOWS

The 2.50" discharge outlets located on the right side pump panel will be furnished with a 2.50" (F) National Standard hose thread x 2.50" (M) National Standard hose thread, chrome plated, 45 degree elbow.

The elbow will be Pierce VLH, which incorporates an exclusive thread design to automatically relieve stored pressure in the line when disconnected.

There will be a 4.00" discharge outlet with a 3.00" valve with a 3.00" ball, installed on the right side of the apparatus, terminating with a 4.00" (M) National Standard hose thread adapter. This discharge outlet will be actuated with a handwheel control with position indicator at the pump operator's control panel.

ADDITIONAL RIGHT SIDE OUTLET ELBOWS

The 4.00" outlet will be furnished with a TFT AH3ST-NP 4.00" (F) National Standard hose thread x 5.00" Storz elbow adapter with Storz cap.

ADDITIONAL FRONT DISCHARGE OUTLET & ACCESSORIES

No additional front outlets or accessories are required.

REAR DISCHARGE OUTLET

There will be Three (3) discharge outlets piped to the rear of the hose bed, two (2) on the passenger's side and one (1) on the driver's side, installed so proper clearance is provided for spanner wrenches or adapters. Plumbing will consist of 2.50" piping along with a 2.50" full flow ball valve with the control from the pump operator's panel.

REAR OUTLET ELBOWS

The 2.50" discharge outlets located at the rear of the apparatus will be furnished with a 2.50" (F) National Standard hose thread x 2.50" (M) National Standard hose thread, chrome plated, 45 degree elbow.

The elbow will be Pierce VLH, which incorporates an exclusive thread design to automatically relieve stored pressure in the line when disconnected.

DISCHARGE CAPS/ INLET PLUGS

Chrome plated, rocker lug, caps with chain will be furnished for all discharge outlets 1.00" thru 3.00" in size, besides the pre-connected hose outlets.

Chrome plated, rocker lug, plugs with chain will be furnished for all auxiliary inlets 1.00" thru 3.00" in size.

The caps and plugs will incorporate a thread design to automatically relieve stored pressure in the line when disconnected.

OUTLET BLEEDER VALVE

A 0.75" bleeder valve will be provided for each outlet 1.50" or larger. Automatic drain valves are acceptable with some outlets if deemed appropriate with the application.

The valves will be located behind the panel with a T swing style handle control extended to the outside of the side pump panel.

The handles will be chrome plated and provide a visual indication of valve position.

The T swing handle will provide an ergonomic position for operating the valve without twisting the wrist and provides excellent leverage.

Bleeders will be located at the bottom of the pump panel. They will be properly labeled identifying the discharge they are plumbed in to.

The water discharged by the bleeders will be routed below the chassis frame rails.

DELUGE RISER

A 3.00" deluge riser will be installed above the pump in such a manner that a monitor can be mounted and used effectively. Piping will be rigidly braced and installed securely so no movement develops when the line is charged. The riser will be gated and controlled at the pump operator's panel.

Any 3.00 inch or larger discharge valve will be a slow-operating valve in accordance with NFPA 16.7.5.3.

DELUGE OUTLET SPECIAL INSTRUCTIONS

The deluge gun outlet will be located rearward centered in dunnage pan see drawing .

MONITOR

A Task Force Crossfire XFC-52 monitor package will be furnished and properly installed on the deluge riser. The monitor will include a M-R nozzle, 10" stream straightener and quad stacked tips. The portable base unit with folding legs and a safety valve will have (2) 2.50" female NST inlets. The monitor will be painted as provided by monitor manufacturer.

The deluge riser will have a Task Force Tips, Model XFF-APL truck mount adapter for mounting the CrossFire monitor.

CROSSLAY HOSE BEDS

Two (2) crosslays with 1.50" outlets will be provided. Each bed to be capable of carrying 200' of 1.75" hose and will be plumbed with 2.00" i.d. pipe and gated with a 2.00" quarter turn ball valve.

Outlets to be equipped with a 1.50" National Standard hose thread chrome adapter located below the crosslay hosebed smooth aluminum trays, and will be staggered.

The crosslay controls will be at the pump operator's panel.

A removable tray will be provided for the crosslay hosebed. The crosslay tray will be as wide as the crosslay opening will allow and constructed of smooth aluminum to provide a lightweight sturdy tray. Two (2) hand holes will be in the floor and additional hand holes will be provided in the sides for easy

removal and installation from the compartment. The floor of the trays will be perforated to allow for drainage and hose drying. Tray will be held in place by a mechanical spring loaded stainless steel latch that automatically deploys upon loading the tray to hold the trays in place during transit.

Vertical scuffplates, constructed of stainless steel, will be provided at the front and rear ends of the bed on each side of vehicle.

Crosslay bed flooring will consist of removable perforated brushed aluminum.

CROSSLAY/DEADLAY HOSE RESTRAINT

There will be red vinyl end flap provided across each end of two (2) crosslay/deadlay opening(s) to secure the hose during travel.

Each vinyl end flap will be permanently attached at the bottom of the crosslay/deadlay opening(s). Two (2) seatbelt fasteners will be used on the bottom with the female end permanently attached to the bottom of the vinyl. The male receiver end will be hinged and permanently attached to the crosslay opening.

CROSSLAY COVER

A bi-fold 0.19" aluminum treadplate cover will be installed over the crosslay hose beds. It will include a latch at each end of the cover to hold it securely in place, a chrome grab handle at each end for opening and closing the cover and a foam rubber gasket where the cover comes into contact to a painted surface. The cover will be held short on both end to avoid any clearance issue with the push up lights located on the side of the pump house.

CROSSLAY 8.00" LOWER THAN STANDARD

The crosslays will be lowered 8.00" from standard.

BOOSTER HOSE REEL

A Hannay electric rewind booster hose reel, with a 2/3 H.P. motor will be installed over the pump in a recessed open compartment on the left side of the apparatus.

The exterior finish of the reel will be painted #269 gray from the reel manufacturer.

A polished stainless steel roller and guide assembly will be mounted on the reel side of the apparatus.

Discharge control will be provided at the pump operator's panel. Plumbing to the reel will consist of 1.50" Aeroquip hose and a 1.50" valve.

The reel will include NPSH threaded couplings.

Reel motor will be protected from overload with a circuit breaker rated to match the motor.

Two (2) electric rewind control switches will be provided, one (1) installed on each pump panel.

Booster hose, 1.00" diameter and 150 feet, with chrome plated Barway, or equal couplings will be provided. The couplings will have 1" NPSH threads.

Working pressure of the booster hose will be a minimum of 800 psi.

Capacity of the hose reel will be 200 feet of 1.00" booster hose.

HOSE REEL BLOWOUT

one (1) hose reel blowout(s) will be furnished to blow out any remaining water from the reel(s). The blowout will be piped from the wet tank of the brake system to the reel, and will be controlled at the pump operator's panel.

There will be one (1) additional polished stainless steel roller and guide assembly mounted officer side top of pump house (to mirror driver side).

COVER

An aluminum treadplate cover will be installed over the hose reel motor solenoid and wiring. The cover will protect the solenoid and wiring from damage.

HUSKY 3 FOAM PROPORTIONER

A Pierce Husky® 3 foam proportioning system will be provided. The Husky 3 is an on demand, automatic proportioning, single point, direct injection system suitable for all types of Class A and B foam concentrates, including the high viscosity (6000 cps), alcohol resistant Class B foams. Operation will be based on direct measurement of water flow, and remain consistent within the specified flows and pressures. The system will automatically proportion foam solution at rates from .1 percent to 3 percent regardless of variations in water pressure and flow, up to the maximum rated capacity of the foam concentrate pump.

The design of the system will allow operation from draft, hydrant, or relay operation.

System Capacity

The system will have the ability to deliver the following minimum foam solution flow rates at accuracies that meet or exceed NFPA requirements at a pump rating of 150 psi.

100 gpm @ 3 percent

300 gpm @ 1 percent

600 gpm @ 0.5 percent

Class A foam setting in .1 percent increments from .1 percent to 1 percent. Typical settings of 1 percent, .5 percent and .3 percent (maximum capacity will be limited to the plumbing and water pump capacity).

Control System

The system will be equipped with a digital electronic control display located on the pump operators panel. Push button controls will be integrated into the panel to turn the system on/off, control the foam percentage, and to set the operation modes.

The percent of injection will have a preset. This preset can be changed at the fire department as desired. The percent of injection will be able to be easily changed at the scene to adjust to changing demands.

Three (3) .50 tall LEDs will display the foam percentage in numeric characters. Three (3) indicator LEDs will also be included, one (1) green, one (1) red, and one (1) yellow. The LEDs will indicate various system operation or error states.

The indications will be:

- Solid Green - System On
- Solid Red - Valve Position Error
- Solid Yellow - Priming System
- Flashing Green - Injecting Foam
- Flashing Red - Low Tank Level
- Flashing Yellow - Refilling Tank

The control display will house a microprocessor, which receives input from the systems water flow meter while also monitoring the position of the foam concentrate pump. The microprocessor will compare the values of the water flow versus the position/rate of the foam pump, to ensure the proportion rate is accurate. One (1) check valve will be installed in the plumbing to prevent foam from contaminating the water pump.

Hydraulic Drive System

The foam concentrate pump will be powered by an electric over hydraulic drive system. The hydraulic system and motor will be integrated into one (1) unit.

Foam Concentrate Pump

The foam concentrate pump will be of positive displacement, self-priming; linear actuated design, driven by the hydraulic system. The pump will be constructed of brass body; chrome plated stainless steel shaft, with a stainless steel piston. In order to increase longevity of the pump, no aluminum will be present in its construction.

A relief system will be provided which is designed to protect the drive system components and prevent over pressuring the foam concentrate pump

The foam concentrate pump will have minimum capacity for 3 gpm with all types of foam concentrates with a viscosity at or below 6000 cps including protein, fluoroprotein, AFFF, FFFP, or AR-AFFF. The system will deliver only the amount of foam concentrate flow required, without recirculating foam back to the storage tank. Recirculating foam concentrate back to the storage tank can cause agitation and premature foaming of the concentrate, which can result in system failure. The foam concentrate pump will be self-priming and have the ability to draw foam concentrate from external supplies such as drums or pails.

External Foam Concentrate Connection

An external foam pick-up will be provided to enable use of a foam agent that is not stored on the vehicle. The external foam pick-up will be designed to allow continued operation after the on-board foam tank is empty, or the use of foam different than the foam in the foam tank.

Panel Mounted External Pick-Up Connection / Valve

A bronze three (3)-way valve will be provided. The unit will be mounted to the pump panel. The valve unit will function as the foam system tank to pump valve and external suction valve. The external foam pick-up will be one (1) 0.75" male connection GHT (garden hose thread) with a cap.

Pick-Up Hose

A 0.75" flexible hose with an end for insertion into foam containers will be provided. The hose will be supplied with a 0.75" female swivel GHT (garden hose thread) swivel connector. The hose will be shipped loose.

Discharges

The foam system will be plumbed to the hose reel in left side of dunnage area, left rear outlet, front crosslay, rear crosslay, left rear outlet inboard and right rear outlet inboard.

System Electrical Load

The maximum current draw of the electric motor and system will be no more than 55 amperes at 12 VDC.

SINGLE FOAM TANK REFILL

The foam system's proportioning pump will be used to fill the foam tank. This will allow use of the auxiliary foam pick-up to pump the foam from pails or a drum on the ground into the foam tank. A foam shut-off switch will be installed in the fill dome of the tank to shut the system down when the tank is full. The fill operation will be controlled by a mode in the foam system controller. While the proportioner pump is filling the tank, the controller will display a flashing yellow LED to indicate that the tank is filling. When the tank is full, as determined by the float switch in the tank dome, the pump will stop and the controller will shut the yellow LED off. If it attempted to use tank fill and the refill valve and suction valve are in the wrong position(s), then a red LED will illuminate to indicate the improper valve position(s). When the valves are positioned properly, then filling will commence.

FOAM TANK

The foam tank will be an integral portion of the polypropylene water tank. The cell will have a capacity of 20 gallons of foam with the intended use of Class A foam. The foam cell will reduce the capacity of the water tank. The foam cell will have a screen in the fill dome and a breather in the lid.

FOAM TANK DRAIN

The foam tank drain will be a 1.00" quarter turn drain valve located inside the pump/plumbing compartment.

DRAWING, PUMP OPERATOR'S PANEL

A detailed drawing to scale of the left side pump panel will be provided for approval prior to construction. This drawing will include all of the gauges and controls located on the pump operator's (left side) panel.

PUMP PANEL CONFIGURATION

The pump panel configuration will be arranged and installed in an organized manner that will provide user-friendly operation.

PUMP AND GAUGE PANEL

The pump and gauge panels will be constructed of aluminum with a painted FormCoat black finish. A polished aluminum trim molding will be provided around each panel.

PUMP ACCESS

Right Side Panel

The right side upper pump panel will be removable.

Panel Fastener

The removable panels will be secured with chrome flush lift and turn latch.

The left side pump panels will be attached with screws.

The right side lower pump panel (drain bank) will be attached with screws.

Front Pump House Access

On the front of the pump house structure, provisions will be provided for access to the pump. A(n) aluminum treadplate panel will incorporate two D- handle latches to aid in removing the panel.

PUMP COMPARTMENT LIGHT

A pump compartment light will be provided inside the right side pump enclosure and accessible through a door on the pump panel.

A .125" weep hole will be provided in each light lens, preventing moisture retention.

Engine monitoring graduated LED indicators will be incorporated with the pressure controller.

Also provided at the pump panel will be the following:

- Master Pump Drain Control

THROTTLE READY GREEN INDICATOR LIGHT

There will be a green indicator light integrated with the pressure governor and/or engine throttle installed on the pump operators panel that is activated when the pump is in throttle ready mode.

OK TO PUMP INDICATOR LIGHT

There will be a green indicator light installed on the pump operators panel that is activated when the pump is in Ok To Pump mode.

AIR HORN SWITCH

An air horn control switch will be provided at the pump operator's control panel. This switch will be red and properly labeled. The switch will be located within easy reach of the operator in the electrical switch panel.

DRAINS, ABOVE RUNNING BOARDS, LS & RS

Both the left side and right side drains will be installed above the running boards, on the pump panels.

ELECTRIC GAUGE HEATER

An Innovative Controls (IC) 12v electric gauge heater controller and heat tape(s) will be provided for all of the individual pressure gauges, master pump gauges, the pump test port and the pressure governor pressure transducer(s) in the pump house area if so equipped

All gauge heater tape(s) will be wrapped as close to the gauge/test port/pressure transducer and back to the pump/valve/fittings as possible to prevent the fluid from freezing.

HEATER, PUMP COMPARTMENT

A hot water heater rated for 33,000 BTU will be installed in the pump compartment.

Controls for the heater will be located at the pump operator's panel.

The pump compartment will be enclosed at the top to retain the heat generated by the heater inside the pump compartment.

RUBBER SEAL AROUND PUMP PANEL OPENINGS

Rubber seals will be installed around each inlet, outlet and valve control handles (If necessary) on all of the pump panels. The rubber seals will be designed to retain as much heat as possible in the pump house.

VACUUM AND PRESSURE GAUGES

The pump vacuum and pressure gauges will be liquid filled and manufactured by Class 1 Incorporated ©.

The gauges will be a minimum of 4.50" in diameter and will have white faces with black lettering, with a pressure range of 30.00"-0-600#.

The pump pressure and vacuum gauges will be installed adjacent to each other at the pump operator's control panel.

Test port connections will be provided at the pump operator's panel. One will be connected to the intake side of the pump, and the other to the discharge manifold of the pump. They will have 0.25 in. standard pipe thread connections and polished stainless steel plugs. They will be marked with a label.

PRESSURE GAUGES

The individual "line" pressure gauges for the discharges will be Class 1© interlube filled.

They will be 2.50" in diameter and have white faces with black lettering.

Gauges will have a pressure range of 0-400#.

The individual pressure gauge will be installed as close to the outlet control as practical.

WATER LEVEL GAUGE

An electric water level gauge will be incorporated in the pressure controller that registers water level by means of nine (9) LEDs. They will be at 1/8 level increments with a tank empty LED. The LEDs will be a bright type that is readable in sunlight, and have a full 180-degree of clear viewing.

To further alert the pump operator, the gauge will have a warning flash when the tank volume is less than 25 percent. The gauge will have down chasing LEDs when the tank is almost empty.

The level measurement will be ascertained by sensing the head pressure of the fluid in the tank or cell.

MINI SLAVE UNIT

An electric water level gauge will be provided in the cab that registers water level by means of five (5) LEDs. They will be at 1/4 level increments with a tank empty LED. The LEDs will be a bright type that are readable in sunlight and have a full 180-degree of clear viewing.

The water level gauge in the cab will be activated when the parking brake is applied.

WATER LEVEL GAUGE

There will be two (2) additional water level indicator, Whelen®, Model PSTANK2, LED module with a chrome trim, installed one (1) on the cab behind the left cab door and one (1) on the cab behind the right cab door.

This light module will include four (4) colored levels, and function similar to the water level indicator located at the operators panel:

- First green module indicates a full water level
- Second blue module indicates a water level above 3/4 full
- Third amber module indicates a water level above 1/2 full
- Last red module indicates a water level above 1/4 full and empty
 - Above 1/4 this light will be steady burning
 - At empty this light will be flashing

This module will be activated when the when either the pump is in gear, or the parking brake is applied.

FOAM LEVEL GAUGE

An electronic foam level gauge will be provided on the operator's panel that registers foam level by means of five (5) colored LED lights. The lights will be durable, ultra-bright five (5) LED design viewable through 180 degrees. The foam level indicators will be as follows:

- 100 percent = Green
- 75 percent = Yellow
- 50 percent = Yellow
- 25 percent = Yellow
- Refill = Red

The light will flash when the level drops below the given level indicator to provide an eighth of a tank indication. To further alert the pump operator, the lights will flash sequentially when the foam tank is empty.

The level measurement will be based on the sensing of head pressure of the fluid in the tank.

The display will be constructed of a solid plastic material with a chrome plated die cast bezel to reduce vibrations that can cause broken wires and loose electronic components. The encapsulated design will provide complete protection from foam and environmental elements. An industrial pressure transducer will be mounted to the outside of the tank. The display will be able to be calibrated in the field and will measure head pressure to accurately show the tank level.

STEP/LIGHT SHIELD

There will be an aluminum treadplate stepping surface no less than 8.00" deep and properly reinforced to support a man's weight, installed over the pump operators panel.

- There will be 12 volt DC white LED lights installed under the step to illuminate the controls, switches, essential instructions, gauges, and instruments necessary for the operation of the apparatus. These lights will be activated by the pump panel light switch. Additional lights will be included every 18.00" depending on the size of the pump house.
- One (1) pump panel light will come on when the pump is in ok to pump mode.

There will be a light activated above the pump panel light switch when the parking brake is applied. This is to afford the operator some illumination when first approaching the control panel.

There will be one (1) white LED, step light provided above this step. In order to ensure exceptional illumination, each step light will provide a minimum of 25 foot-candles (fc) covering an entire 15.00" x 15.00" square placed 10.00" below the light and a minimum of 1.5 fc covering an entire 30.00" x 30.00" square at the same 10.00" distance below the light. The step light will be activated by the pump panel light switch.

AIR HORN SYSTEM

Two (2) Hadley®, eTone, chrome air horns will be recessed in the front bumper. The air horn system will be piped to the air brake system wet tank utilizing 0.38" tubing. A pressure protection valve will be installed to prevent the loss of air in the brake system.

Air Horn Location

The air horn(s) will be located TBD.

Air Horn Control

The air horn(s) will be activated by the following:

- Left side lanyard. The lanyard to be a link chain inside vinyl tubing.

ELECTRONIC SIREN

A Whelen, Model: 295SLSC1, electronic siren with a plug-in, detachable noise canceling microphone will be provided.

This siren to be active when the battery switch is on and that emergency master switch is on.

Electronic siren head will be recessed in the driver side inside switch panel.

ELECTRONIC SIREN CONTROL

The electronic siren will be activated by the following:

- The right side push button.
- The right side foot switch.

SPEAKERS

There will be two (2) Whelen®, Model SA315P, black nylon composite, 100-watt, speakers with through bumper mounting brackets and polished stainless steel grille provided. Each speaker will be connected to the siren amplifier.

There will be one (1) speaker recessed in the passenger's side corner and one (1) speaker recessed in the driver's side corner of the front bumper.

LIGHTBAR, CAB ROOF

One (1) 56.00" Whelen, Justice LED lightbar will be mounted on the cab roof.

This lightbar will include the following:

- Four (4) red flashing CON3 LED modules facing forward.
- Two (2) white flashing CON3 LED modules facing forward.
- Two (2) red flashing LIN6 LED modules one (1) in each front corner.
- Two (2) red flashing LIN6 LED modules, one (1) in each rear corner.

All lenses will be clear.

One (1) switch located on a switch panel in the cab will control this lightbar.

To meet NFPA requirements, all white warning lights will be disabled when the parking brake is applied.

FRONT ZONE LOWER LIGHTS

There will be two (2) Whelen®, Model M6#, LED flashing warning lights installed on the cab face above the headlights, in a common bezel with the directional lights.

- The driver's side outside light to be red to the outside and white to the inside
- The passenger's side outside light to be red to the outside and white to the inside

Both lights will include a clear lens.

There will be a switch located in the cab on the switch panel to control the lights.

Any white warning LEDs will be deactivated and any amber warning lights will be activated when the parking brake is applied.

HEADLIGHT FLASHER

The high beam headlights will flash alternately between the left and right side.

There will be a switch installed in the cab on the switch panel to control the high beam flash. This switch will be live when the battery switch and the emergency master switches are on.

The flashing will automatically cancel when the hi-beam headlight switch is activated or when the parking brake is set.

SIDE ZONE LOWER LIGHTING

There will be six (6) Whelen®, Model M6*C flashing LED warning lights with chrome trim provided per the following:

- Two (2) lights, one (1) each side on the bumper extension. The side front lights to be red to the front and amber to the rear.
- Two (2) lights, lower cab corner. The side middle lights to be red.
- Two (2) lights, over rear wheels. The side rear lights to be red.
- The lights will include clear lenses.

There will be a switch in the cab on the switch panel to control the lights.

White LEDs will be disabled when the parking brake is applied.

REAR ZONE LOWER LIGHTING

There will be two (2) Whelen®, Model M6*C, LED flashing warning lights located at the rear of the apparatus.

- The driver's side rear light to be red
- The passenger's side rear light to be red

Both lights will include a lens that is clear.

There will be a switch located in the cab on the switch panel to control the lights.

REAR/SIDE ZONE UPPER WARNING LIGHTS

There will be two (2) Whelen®, Model L31H*FN, LED warning beacons provided at the rear of the truck, located one (1) each side. There will be a switch located in the cab on the switch panel to control the beacons.

The color of the lights will be red LEDs with both domes clear.

The left side rear warning light will be mounted on top of the compartmentation with all wiring totally enclosed. The clearance/marker light will be mounted to the side of the compartment ridge.

The right side rear warning light will be mounted on a low mount stainless steel bracket with all wiring totally enclosed. This brackets will also support the clearance/marker light.

The rear deck lights will be mounted on the beavertail flange to keep the overall height as low as possible.

TRAFFIC DIRECTING LIGHT

There will be one (1) Whelen®, Model TAL65, 36.00" long x 2.87" high x 2.25" deep, amber LED traffic directing light installed at the rear of the apparatus.

The Whelen, Model TACTL5, control head will be included with this installation.

The controller will be energized when the battery switch is on.

The auxiliary flash to be activated when the emergency master switch is on.

This traffic directing light will be recessed within a treadplate step at the rear of the apparatus.

The traffic directing light controller will be located within the switch panel on the center console. The controller will be within easy reach of the driver.

ELECTRICAL SYSTEM GENERAL DESIGN FOR ALTERNATING CURRENT

The following guidelines will apply to the 120/240 VAC system installation:

General

Any fixed line voltage power source producing alternating current (ac) line voltage will produce electric power at 60 cycles plus or minus 3 cycles.

Except where superseded by the requirements of NFPA 1901, all components, equipment and installation procedures will conform to NFPA 70, National Electrical Code (herein referred to as the NEC).

Line voltage electrical system equipment and materials included on the apparatus will be listed and installed in accordance with the manufacturer's instructions. All products will be used only in the manner for which they have been listed.

Grounding

Grounding will be in accordance with Section 250-6 "Portable and Vehicle Mounted Generators" of the NEC. Ungrounded systems will not be used. Only stranded or braided copper conductors will be used for grounding and bonding.

An equipment grounding means will be provided in accordance with Section 250-91 (Grounding Conductor Material) of the NEC.

The grounded current carrying conductor (neutral) will be insulated from the equipment grounding conductors and from the equipment enclosures and other grounded parts. The neutral conductor will be colored white or gray in accordance with Section 200-6 (Means of Identifying Grounding Conductors) of the NEC.

In addition to the bonding required for the low voltage return current, each body and driving or crew compartment enclosure will be bonded to the vehicle frame by a copper conductor. This conductor will have a minimum amperage rating of 115 percent of the nameplate current rating of the power source specification label as defined in Section 310-15 (amp capacities) of the NEC. A single conductor properly sized to meet the low voltage and line voltage requirements will be permitted to be used.

All power source system mechanical and electrical components will be sized to support the continuous duty nameplate rating of the power source.

Operation

Instructions that provide the operator with the essential power source operating instructions, including the power-up and power-down sequence, will be permanently attached to the apparatus at any point where such operations can take place.

Provisions will be made for quickly and easily placing the power source into operation. The control will be marked to indicate when it is correctly positioned for power source operation. Any control device used in the drive train will be equipped with a means to prevent the unintentional movement of the control device from its set position.

A power source specification label will be permanently attached to the apparatus near the operator's control station. The label will provide the operator with the following information:

- Rated voltage(s) and type (ac or dc)
- Phase
- Rated frequency
- Rated amperage
- Continuous rated watts
- Power source engine speed

Direct drive (PTO) and portable generator installations will comply with Article 445 (Generators) of the NEC.

Overcurrent protection

The conductors used in the power supply assembly between the output terminals of the power source and the main over current protection device will not exceed 144.00" (3658 mm) in length.

For fixed power supplies, all conductors in the power supply assembly will be type THHW, THW, or use stranded conductors enclosed in nonmetallic liquid tight flexible conduit rated for a minimum of 194 degree Fahrenheit (90 degrees Celsius).

For portable power supplies, conductors located between the power source and the line side of the main overcurrent protection device will be type SO or type SEO with suffix WA flexible cord rated for 600-volts at 194 degrees Fahrenheit (90 degrees Celsius).

Wiring Methods

Fixed wiring systems will be limited to the following:

- Metallic or nonmetallic liquid tight flexible conduit rated at not less than 194 degrees Fahrenheit (90 degrees Celsius)
- or
- Type SO or Type SEO cord with a WA suffix, rated at 600 volts at not less than 194 degrees Fahrenheit (90 degrees Celsius)

Electrical cord or conduit will not be attached to chassis suspension components, water or fuel lines, air or air brake lines, fire pump piping, hydraulic lines, exhaust system components, or low voltage wiring. In addition the wiring will be run as follows.

- Separated by a minimum of 12.00" (305 mm), or properly shielded, from exhaust piping
- Separated from fuel lines by a minimum of 6.00" (152 mm) distance

Electrical cord or conduit will be supported within 6.00" (152 mm) of any junction box and at a minimum of every 24.00" (610 mm) of continuous run. Supports will be made of nonmetallic materials or corrosion protected metal. All supports will be of a design that does not cut or abrade the conduit or cable and will be mechanically fastened to the vehicle.

Wiring Identification

All line voltage conductors located in the main panel board will be individually and permanently identified. The identification will reference the wiring schematic or indicate the final termination point. When prewiring for future power sources or devices, the unterminated ends will be labeled showing function and wire size.

Wet Locations

All wet location receptacle outlets and inlet devices, including those on hardwired remote power distribution boxes, will be of the grounding type provided with a wet location cover and installed in accordance with Section 210-7 "Receptacles and Cord Connections" of the NEC.

All receptacles located in a wet location will be not less than 24.00" (610 mm) from the ground. Receptacles on off-road vehicles will be a minimum of 30.00" (762 mm) from the ground.

The face of any wet location receptacle will be installed in a plane from vertical to not more than 45 degrees off vertical. No receptacle will be installed in a face up position.

Dry Locations

All receptacles located in a dry location will be of the grounding type. Receptacles will be not less than 30.00" (762 mm) above the interior floor height.

All receptacles will be marked with the type of line voltage (120-volts or 240-volts) and the current rating in amps. If the receptacles are direct current, or other than single phase, they will be so marked.

Listing

All receptacles and electrical inlet devices will be listed to UL 498, Standard for Safety Attachment Plugs and Receptacles, or other appropriate performance standards. Receptacles used for direct current voltages will be rated for the appropriate service.

Electrical System Testing

The wiring and associated equipment will be tested by the apparatus manufacturer or the installer of the line voltage system.

The wiring and permanently connected devices and equipment will be subjected to a dielectric voltage withstand test of 900-volts for one (1) minute. The test will be conducted between live parts and the neutral conductor, and between live parts and the vehicle frame with any switches in the circuit(s) closed. This test will be conducted after all body work has been completed.

Electrical polarity verification will be made of all permanently wired equipment and receptacles to determine that connections have been properly made.

Operational Test per Current NFPA 1901 Standard

The apparatus manufacturer will perform the following operation test and ensure that the power source and any devices that are attached to the line voltage electrical system are properly connected and in working order. The test will be witnessed and the results certified by an independent third-party certification organization.

The prime mover will be started from a cold start condition and the line voltage electrical system loaded to 100 percent of the nameplate rating.

The power source will be operated at 100 percent of its nameplate voltage for a minimum of two (2) hours unless the system meets category certification as defined in the current NFPA 1901 standard.

Where the line voltage power is derived from the vehicle's low voltage system, the minimum continuous electrical load as defined in the current NFPA 1901 standard will be applied to the low voltage electrical system during the operational test.

GENERATOR

The apparatus will be equipped with a complete alternating current electrical power system. The generator will be a Harrison 6.0kW "C-Gen" hydraulic unit. The hydraulic generator will include the following features:

- "Flow Thru" ventilation system to cool the alternator
- Dual fan technology featuring a vertical exhaust
- Automotive type hydraulic oil cooling system
- 25% oversized "Plus Powered" alternator
- Harrison "Delta-Q" variable displacement hydraulic pump utilizing dual counterbalanced controls
- Remote mount reservoir
- Steel frame with a treadplate plate cover
- Cover able to support a 300 pound load
- Gear driven hydraulic motor coupled with an alternator using a Morse taper design

The wiring and generator installation will conform to the present National Electrical Codes Standards of the NFPA. The installation will be designed for continuous operation without overheating and undue stress on components.

Generator Performance

- Continuous Duty Rating: 6,000 watts
- Nominal Volts: 120/240
- Amperage: 50 amps @ 120 volts, 25 amps @ 240 volts

- Phase: Single
- Cycles: 60 hertz
- Engine Speed at Engagement: Idle

The output of the generator will be controlled by a pressure compensated hydraulic system. Electronic controls will not be used. The generator will be driven by a transmission power take off unit, through a hydraulic pump and motor. The generator will include an electrical control inside the cab. The hydraulic engagement supply will be operational at any time (no interlocks). A hot shift PTO will be used to drive the hydraulic pump.

Generator Instruments and Controls

To properly monitor the generator performance, the following instrumentation will be furnished:

- Voltage meter
- High hydraulic oil temperature warning light
- Generator run hourmeter (mounted on the generator)
- "Power On" indicator (in the cab)

The voltage meter and hydraulic oil temperature indicator will be installed near eye level in the compartment and flush-mounted in an appropriately sized, weatherproof, electrical enclosure. All instruments used will be accurate within +/- 2%.

Generator Wiring:

The system will be installed by highly qualified electrical technicians to assure the required level of safety and protection to the fire apparatus operators. The wiring, electrical fixtures, and components will be to the highest industry quality standards available on the domestic market. The equipment will be the type as designed for mobile type installations subject to vibration, moisture, and severe continuous usage. The following electrical components will be the minimum acceptable quality standards for this apparatus:

Wiring:

All electrical wiring will be fine stranded copper type. The wire will be sized to the load and circuit breaker rating; 10 gauge on 30 amp circuits, 12 gauge on 20 amp circuits and 14 gauge on 15 amp circuits. The cable will be run in corner areas and extruded aluminum pathways built into the body for easy access.

Load Center:

The main load center will be Cutler Hammer with circuit breakers rated to load demand.

Circuit Breakers:

Individual breakers will be provided for all on-line equipment.

GENERATOR LOCATION

The generator will be mounted in the see drawingThe flooring in this area will be either reinforced or constructed, in such a manner, that it will handle the additional weight of the generator.

GENERATOR START

There will be a switch provided on the cab instrument panel to engage the generator.

CIRCUIT BREAKER PANEL

The circuit breaker panel will be located high left on the back wall of compartment LS3.

GENERATOR COVER OVER PUMP

The generator shall be totally enclosed with a cover constructed of .125" bright aluminum treadplate. The cover shall be provided with adequate ventilation for the specific generator, and knockouts on the side walls, and have any necessary access doors for maintenance or operation.

The enclosure shall have two (2) lift-up doors, with grab handles, one to access the generator area and the other to access the cord reel . The hinges for the lift-up doors shall be to the front of the truck, and the doors shall be secured with lift-and-turn latches mounted to the rear of the truck.

ELECTRIC CORD REEL

Furnished with the 120 volt AC electrical system will be a Hannay, Series 1600, cord reel. The reel will be provided with a 12-volt electric rewind switch, that is guarded to prevent accidental operation and labeled for its intended use. The switch will be protected with a fuse and installed at a height not to exceed 72.00" above the operators standing position.

The exterior finish of the reel(s) will be painted #269 gray from the reel manufacturer.

A captive roller assembly to be provided to aid in the payout and loading of the reel. A ball stop will be provided to prevent the cord from being wound on the reel.

A label will be provided in a readily visible location adjacent to the reel. The label will indicate current rating, current type, phase, voltage and total cable length.

A total of two (2) cord reels will be provided one (1) above the pump area, opposite side of the generator.

The cord reel will be configured with three (3) conductors.

CORD

Provided for electric distribution will be one (1) length installed on the reel of 200 feet of black 10/3 electrical cord. No connector will be installed on the end of the cord.

CORD

Provided for electric distribution will be one (1) length installed on the reel of 200 feet of yellow 10/3 electrical cord, weather resistant 105 degree Celsius to -50 degree Celsius, 600 volt jacketed SOOW cord. No connector will be installed on the end of the cord.

PORTABLE JUNCTION BOX

There will be two (2) Akron EJBX electric junction box(es) provided.

There will be a cable strain relief and direct connection, no plug provided for each box.

Each box will be provided with the following:

- two (2) 15/20 amp 120 volt AC duplex straight blade receptacle with flip up covers
- two (2) 20 amp 120 volt AC twist lock single receptacles with flip up covers
- a 120 volt AC light inside the box

120 VOLT RECEPTACLE

There will be one (1), 15/20 amp 120 volt AC three (3) wire straight blade duplex receptacle(s) with interior stainless steel wall plate(s), installed med cabinet, centered, up high, rear wall. The NEMA configuration for the receptacle(s) will be 5-20R.

The receptacle(s) will be powered from the shoreline inlet.

There will be a label installed near the receptacle(s) that state the following:

- Line Voltage
- Current Rating (amps)
- Phase
- Frequency

120 VOLT RECEPTACLE

There will be one (1), 15/20 amp 120 volt AC three (3) wire straight blade duplex receptacle(s) with interior duplex flip up cover(s), installed TBD. The NEMA configuration for the receptacle(s) will be 5-20R.

The receptacle(s) will be powered from the shoreline inlet.

There will be a label installed near the receptacle(s) that state the following:

- Line Voltage
- Current Rating (amps)
- Phase
- Frequency

120 VOLT RECEPTACLE

There will be three (3), 15/20 amp 120 volt AC three (3) wire straight blade duplex receptacle(s) with exterior flip up cover(s), installed DS over rear wheel panel, PS over rear wheel panel, rear body. The NEMA configuration for the receptacle(s) will be 5-20R.

The receptacle(s) will be powered from the on board generator.

There will be a label installed near the receptacle(s) that state the following:

- Line Voltage
- Current Rating (amps)
- Phase
- Frequency

NFPA REQUIRED LOOSE EQUIPMENT PROVIDED BY FIRE DEPARTMENT

The following loose equipment as outlined in NFPA 1901, 2016 edition, section 5.9.3 and 5.9.4 will be provided by the fire department.

- 800 ft (60 m) of 2.50" (65 mm) or larger fire hose.
- 400 ft (120 m) of 1.50" (38 mm), 1.75" (45 mm), or 2.00" (52 mm) fire hose.
- One (1) handline nozzle, 200 gpm (750 L/min) minimum.
- Two (2) handline nozzles, 95 gpm (360 L/min) minimum.
- One (1) smoothbore or combination nozzle with 2.50" shutoff that flows a minimum of 250 gpm.
- One (1) SCBA complying with NFPA 1981 for each assigned seating position, but not fewer than four (4), mounted in brackets fastened to the apparatus or stored in containers supplied by the SCBA manufacturer.
- One (1) spare SCBA cylinder for each SCBA carried, each mounted in a bracket fastened to the apparatus or stored in a specially designed storage space(s).
- One (1) first aid kit.
- Four (4) combination spanner wrenches.
- Two (2) hydrant wrenches.
- One (1) double female 2.50" (65 mm) adapter with National Hose threads.
- One (1) double male 2.50" (65 mm) adapter with National Hose threads.
- One (1) rubber mallet, for use on suction hose connections.
- Two (2) salvage covers each a minimum size of 12 ft x 14 ft (3.7 m x 4.3 m).
- One (1) traffic vest for each seating position, each vest to comply with ANSI/ISEA 207, *Standard for High Visibility Public Safety Vests*, and have a five-point breakaway feature that includes two (2) at the shoulders, two (2) at the sides, and one (1) at the front.
- Five (5) fluorescent orange traffic cones not less than 28.00" (711 mm) in height, each equipped with a 6.00" (152 mm) retro-reflective white band no more than 4.00" (152 mm) from the top of the cone, and an additional 4.00" (102 mm) retro-reflective white band 2.00" (51 mm) below the 6.00" (152 mm) band.
- Five (5) illuminated warning devices such as highway flares, unless the five (5) fluorescent orange traffic cones have illuminating capabilities.
- One (1) automatic external defibrillator (AED).
- Four (4) ladder belts meeting the requirements of NFPA 1983, *Standard on Fire Service Life Safety Rope and System Components* (if equipped with an aerial device).
- If the supply hose carried does not use sexless couplings, an additional double female adapter and double male adapter, sized to fit the supply hose carried, will be carried mounted in brackets fastened to the apparatus.
- If none of the pump intakes are valved, a hose appliance that is equipped with one or more gated intakes with female swivel connection(s) compatible with the supply hose used on one side and a swivel connection with pump intake threads on the other side will be carried. Any

intake connection larger than 3.00" (75 mm) will include a pressure relief device that meets the requirements of 16.6.6.

- If the apparatus does not have a 2.50" National Hose (NH) intake, an adapter from 2.50" NH female to a pump intake will be carried, mounted in a bracket fastened to the apparatus if not already mounted directly to the intake.
- If the supply hose carried has other than 2.50" National Hose (NH) threads, adapters will be carried to allow feeding the supply hose from a 2.50" NH thread male discharge and to allow the hose to connect to a 2.50" NH female intake, mounted in brackets fastened to the apparatus if not already mounted directly to the discharge or intake.

SOFT SUCTION HOSE

There will be no soft suction hose provided.

- One (1) extinguisher, 20 pound, CO2

DRY CHEMICAL EXTINGUISHER

There will be One (1) extinguisher, 20 lb dry chemical extinguisher(s) provided.

WATER EXTINGUISHER

One (1) extinguisher,, 2.50 gallon pressurized water, will be provided.

FLATHEAD AXE PROVIDED BY FIRE DEPARTMENT

NFPA 1901, 2016 edition, Section 5.9.4 requires one (1) flathead axe mounted in a bracket fastened to the apparatus.

The axe is not on the apparatus as manufactured. The fire department will provide and mount the axe.

PICKHEAD AXE PROVIDED BY FIRE DEPARTMENT

NFPA 1901, 2016 edition, Section 5.9.4 requires one (1) pickhead axe mounted in a bracket fastened to the apparatus.

The axe is not on the apparatus as manufactured. The fire department will provide and mount the axe.

PAINT PROCESS

The exterior custom cab and/or body painting procedure will consist of a seven (7) step finishing process. A commercial chassis paint process will follow similar processes as determined by the chassis manufacturer. The following procedure will be used by Pierce:

1. Manual Surface Preparation - All exposed metal surfaces on the custom cab and body will be thoroughly cleaned and prepared for painting. Imperfections on the exterior surfaces will be removed and sanded to a smooth finish. Exterior seams will be sealed before painting. Exterior surfaces that will not be painted include; chrome plating, polished stainless steel, anodized aluminum and bright aluminum treadplate.
2. Chemical Cleaning and Pretreatment - All surfaces will be chemically cleaned to remove dirt, oil, grease, and metal oxides to ensure the subsequent coatings bond well. The aluminum surfaces will be properly cleaned and treated using a high pressure, high temperature 4 step Acid Etch process. The steel and stainless surfaces will be properly cleaned and treated using a high

temperature 3 step process specifically designed for steel or stainless. The chemical treatment converts the metal surface to a passive condition to help prevent corrosion. A final pure water rinse will be applied to all metal surfaces.

3. Surfacer Primer - The Surfacer Primer will be applied to a chemically treated metal surface to provide a strong corrosion protective base coat. A minimum thickness of 2 mils of Surfacer Primer is applied to surfaces that require a critical aesthetic finish. The surfacer primer will be a two-component high solids urethane that has excellent sanding properties and an extra smooth finish when sanded.
4. Finish Sanding - The surfacer primer will be sanded with a fine grit abrasive to achieve an ultra-smooth finish. This sanding process is critical to produce the smooth mirror like finish in the topcoat.
5. Sealer Primer - The sealer primer is applied prior to the base coat in all areas that have not been previously primed with the surfacer primer. The sealer primer is a two-component high solids urethane that goes on smooth and provides excellent gloss hold out when top coated.
6. Base coat Paint - Two coats of a high performance, two component high solids polyurethane base coat will be applied. The Base coat will be applied to a thickness that will achieve the proper color match. The Base coat will be used in conjunction with a urethane clear coat to provide protection from the environment.
7. Clear Coat - Two (2) coats of clear coat will be applied over the base coat color. The clear coat is a two-component high solids urethane that provides superior gloss and durability to the exterior surfaces. Lap style doors will be clear coated to match the body. Paint warranty for the roll-up doors will be provided by the roll-up door manufacturer.

Our specifications are written to define cyclic corrosion testing, physical strengths, durability and minimum appearance requirements must be met in order for an exterior paint finish to be considered acceptable as a quality finish.

Each batch of base coat color will be checked for a proper match before painting of the cab and the body. After the cab and body are painted, the color is verified again to make sure that it matches the color standard. Electronic color measuring equipment will be used to compare the color sample to the color standard entered into the computer. Color specifications are used to determine the color match. A Delta E reading will be used to determine a good color match within each family color.

All removable items such as brackets, compartment doors, door hinges, and trim will be removed and separately if required, to ensure paint behind all mounted items. Body assemblies that cannot be finish painted after assembly will be finish painted before assembly.

Environmental Impact

Contractor will meet or exceed all current State regulations concerning paint operations. Pollution control will include measures to protect the atmosphere, water and soil. Controls will include the following conditions:

- Topcoats and primers will be chrome and lead free.
- Metal treatment chemicals will be chrome free. The wastewater generated in the metal treatment process will be treated on-site to remove any other heavy metals.

- Particulate emission collection from sanding operations will have a 99.99 percent efficiency factor.
- Particulate emissions from painting operations will be collected by a dry filter or water wash process. If the dry filter is used, it will have an efficiency rating of 98 percent. Water wash systems will be 99.97 percent efficient.
- Water from water wash booths will be reused. Solids will be removed on a continual basis to keep the water clean.
- Paint wastes will be disposed of in an environmentally safe manner.
- Empty metal paint containers will be recycled to recover the metal.
- Solvents used in clean-up operations will be recycled on-site or sent off-site for distillation and returned for reuse.

Additionally, the finished apparatus will not be manufactured with or contain products that have ozone depleting substances. Pierce will, upon demand, present evidence that the manufacturing facility meets the above conditions and that it is in compliance with the state EPA rules and regulations.

PAINT

The cab and the body will be painted #90 red

PAINT CHASSIS FRAME ASSEMBLY

The chassis frame assembly will be finished with a single system black top coat before the installation of the cab and body, and before installation of the engine and transmission assembly, air brake lines, electrical wire harnesses, etc.

Components treated with epoxy E-coat protection prior to paint:

- Two (2) C-channel frame rails

Components that are included with the chassis frame assembly that will be painted not e-coated are:

- Cross members
- Axles
- Suspensions
- Steering gear
- Battery boxes
- Bumper extension weldment
- Frame extensions
- Body mounting angles
- Rear Body support substructure (front and rear)
- Pump house substructure
- Air tanks
- Steel fuel tank
- Castings
- Individual piece parts used in chassis and body assembly

FILM TECHNICAL PROPERTIES		
PROPERTY	TEST METHOD	PERFORMANCE
Color	-	Black
Film Thickness	-	0.5 - 1.5 Mils
Gloss - 60 Degree	ASTM D523	65 - 85
Pencil Hardness	ASTM D3363	2H Minimum
Direct Impact	ASTM D2794	100 in. - lbs. Minimum
Reverse Impact	ASTM D2794	60 in. - lbs. Minimum
Crosshatch Adhesion	ASTM D3359	4B - 5B
Humidity	ASTM D1735	1000 Hours Minimum
Water Immersion	ASTM D870	250 Hours Minimum
Gravelometer	GM9508P	6 Minimum
Throwpower	GM9535P	12 - 15 in.
Cold rolled steel lab panels, Zinc Phosphate pretreatment, 0.6 mils average film thickness, cured 20 minutes @ 350°F		
PROPERTY	SUBSTRATE PRETREATMENT	SALT SPRAY* 1000 HOURS
Corrosion Resistance	CRS / Zinc Phos / Non-Chrome	1 - 2 mm
*Salt Spray - ASTM B117, cold rolled steel lab panels cured 20 minutes @ 350°F. (Average Total Scribe Creep)		

The E-coat process will meet the technical properties shown.

PAIN, FRONT WHEELS

All wheel surfaces, inside and outside, will be provided with powder coat paint #90 red.



[Powder Coat Aluminum Paint Color]

PAIN, REAR WHEELS

All wheel surfaces, inside and outside, will be provided with powder coat paint #90 red.



[Powder Coat Aluminum Paint Color]

AXLE HUB PAINT

All axle hubs will be painted black #101.

FRONT BUMPER COATING

Durabak™ coating will be provided on the outside exterior of the top and bottom front bumper flanges. It will not be applied on the inside of the flanges.

The material will be textured black .

TRANSIT COATING

All non-painted metal surfaces on the exterior of the vehicle will be sprayed with a corrosion protective coating provided by Carwell. The coating can be removed with soap and water. The coating is made of a linseed oil base and is biodegradable.

The underside non-painted metal surfaces will also be coated with a corrosion protective coating.

COMPARTMENT INTERIOR PAINT

The interior of all compartments will be painted with a gray spatter finish for ease of cleaning and to make it easier to touch up scratches and nicks.

REFLECTIVE STRIPES

Three (3) reflective stripes will be provided across the front of the vehicle and along the sides of the body. The reflective band will consist of a 1.00" gold stripe at the top with a 1.00" gap then a 4.00" white stripe with a 1.00" gap and a 1.00" gold stripe on the bottom.

The reflective band provided on the cab face will be at the headlight level.

REAR CHEVRON STRIPING

There will be alternating chevron striping located on the rear-facing vertical surface of the apparatus. The rear surface, excluding the rear compartment door, will be covered.

The colors will be red and fluorescent yellow green diamond grade.

Each stripe will be 6.00" in width.

This will meet the requirements of the current edition of NFPA 1901, which states that 50% of the rear surface will be covered with chevron striping.

CHEVRON STRIPING ON THE FRONT BUMPER

There will be alternating chevron striping located on the front bumper.

The colors will be fluorescent yellow green and red diamond grade.

The size of the striping will be 6.00".

CAB DOOR REFLECTIVE STRIPE

A 6.00" x 16.00" white reflective stripe will be provided across the interior of each cab door. The stripe will be located approximately 1.00" up from the bottom, on the door panel.

This stripe will meet the NFPA 1901 requirement.

LETTERING

Twenty-one (21) to forty (40) reflective lettering, 3.00" high, with outline and shade will be provided.

LETTERING

There will be reflective lettering, 16.00" high, with outline provided. There will be six (6) letters provided.

LETTERING

Twenty-one (21) to forty (40) reflective lettering, 6.00" high, with outline and shade will be provided.

EMBLEM/S

There will be two (2) reflective emblem/s, installed rear cab doors. Emblem/s will be modeled after the department patch.

CONTINGENCY FUND, FOR EQUIPMENT MOUNTING AND CHANGES

A \$5,000 contingency fund shall be included in the bid price. Any and all amount of the contingency fund not used during the final design of the apparatus shall be refunded to the purchaser and listed as so on the final invoice.

This fund is for changes requested by the bidder during the build process but after the bid.

This fund is for equipment mounting to be provided by the successful bidder. Equipment mounting is to be charged to the fund as time and materials. Time is to be the successful bidders published shop labor rater. Materials are to be at or below manufactures MSRP for the materials and/or mounts.

All changes and or labor utilizing the contingency fund is to be approved by the purchaser prior to use of those funds.

1" BOOSTER HOSE NOZZLE

The dealer is to provide (1) TFT DS1040P 1" Nozzle with Pistol Grip and Bail Control. Nozzle to capable of 10 GPM to 40 GPM.

INSPECTION TRIP #1

An inspection trip will be provided for three (3) people. Trip will take place Main manufacturing facility.

INSPECTION TRIP #2

An inspection trip will be provided for three (3) people. Trip will take place main manufacturing facility.

FIRE APPARATUS PARTS MANUAL

There will be one (1) custom parts manual(s) in USB flash drive format for the complete fire apparatus provided.

The manual(s) will contain the following:

- Job number
- Part numbers with full descriptions
- Table of contents
- Parts section sorted in functional groups reflecting a major system, component, or assembly
- Parts section sorted in alphabetical order
- Instructions on how to locate parts

Each manual will be specifically written for the chassis and body model being purchased. It will not be a generic manual for a multitude of different chassis and bodies.

Service Parts Internet Site

The service parts information included in these manuals are also available on the Pierce website. The website offers additional functions and features not contained in this manual, such as digital photographs and line drawings of select items. The website also features electronic search tools to assist in locating parts quickly.

CHASSIS SERVICE MANUALS

There will be one (1) chassis service manuals on USB flash drives containing parts and service information on major components provided with the completed unit.

The manual will contain the following sections:

- Job number
- Table of contents
- Troubleshooting
- Front Axle/Suspension
- Brakes
- Engine

- Tires
- Wheels
- Cab
- Electrical, DC
- Air Systems
- Plumbing
- Appendix

The manual will be specifically written for the chassis model being purchased. It will not be a generic manual for a multitude of different chassis and bodies.

CHASSIS OPERATION MANUAL

The chassis operation manual will be provided on one (1) USB flash drive.

ONE (1) YEAR MATERIAL AND WORKMANSHIP

A Pierce basic apparatus limited warranty certificate, WA0008, is included with this proposal.

ENGINE WARRANTY

A Cummins **five (5) year** limited engine warranty will be provided. A limited warranty certificate, WA0181, is included with this proposal.

STEERING GEAR WARRANTY

A TRW **one (1) year** limited steering gear warranty will be provided. A copy of the warranty certificate will be submitted with the bid package.

FIFTY (50) YEAR STRUCTURAL INTEGRITY

The Pierce custom chassis frame limited warranty certificate, WA0013, is included with this proposal.

FRONT AXLE ONE (1) YEAR MATERIAL AND WORKMANSHIP WARRANTY

Marmon-Herrington® offers a one (1) year or 12,000 miles warranty for axle systems used under normal service.

REAR AXLE WARRANTY

A Eaton **five (5)-year/100,000 mile** parts and labor warranty will be provided.

ABS BRAKE SYSTEM THREE (3) YEAR MATERIAL AND WORKMANSHIP WARRANTY

A Meritor Wabco™ ABS brake system limited warranty certificate, WA0232, is included with this proposal.

TEN (10) YEAR STRUCTURAL INTEGRITY

The Pierce custom cab limited warranty certificate, WA0012, is included with this proposal.

TEN (10) YEAR PRO-RATED PAINT AND CORROSION

A Pierce cab limited pro-rated paint warranty certificate, WA0055, is included with this proposal.

CAMERA SYSTEM WARRANTY

A Pierce fifty four (54) month warranty will be provided for the camera system.

COMPARTMENT LIGHT WARRANTY

The Pierce 12 volt DC LED strip lights limited warranty certificate, WA0203, is included with this proposal.

TRANSMISSION WARRANTY

The transmission will have a **five (5) year/unlimited mileage** warranty covering 100 percent parts and labor. The warranty will be provided by Allison Transmission.

Note: The transmission cooler is not covered under any extended warranty you may be getting on your Allison Transmission. Please review your Allison Transmission warranty for coverage limitations.

TRANSMISSION COOLER WARRANTY

The transmission cooler will carry a five (5) year parts and labor warranty (exclusive to the transmission cooler). In addition, a collateral damage warranty will also be in effect for the first three (3) years of the warranty coverage and will not exceed \$10,000 per occurrence. A copy of the warranty certificate will be submitted with the bid package.

WATER TANK WARRANTY

A UPF poly water tank limited warranty certificate, WA0195, is included with this proposal.

TEN (10) YEAR STRUCTURAL INTEGRITY

The Pierce apparatus body limited warranty certificate, WA0009, is included with this proposal.

ROLL UP DOOR MATERIAL AND WORKMANSHIP WARRANTY

A Gortite roll-up door limited warranty will be provided. The mechanical components of the roll-up door will be warranted against defects in material and workmanship for the lifetime of the vehicle. A **six (6) year** limited warranty will be provided on painted and satin roll up doors.

The limited warranty certificate, WA0190, is included with this proposal.

PUMP WARRANTY

The Waterous pump will be provided with a Seven (7) year material and workmanship limited warranty.

A copy of the warranty certificate will be submitted with the bid package (no exception).

TEN (10) YEAR PUMP PLUMBING WARRANTY

The Pierce apparatus plumbing limited warranty certificate, WA0035, is included with this proposal.

FOAM SYSTEM WARRANTY

The Husky 3 foam system limited warranty certificate, WA0231, is included with this proposal.

TWO (2) YEAR GENERATOR MATERIAL AND WORKMANSHIP WARRANTY

A Harrison Hydra-Gen generator two (2) year limited warranty will be provided.

TEN (10) YEAR PRO-RATED PAINT AND CORROSION

A Pierce body limited pro-rated paint warranty certificate, WA0057, is included with this proposal.

ONE (1) YEAR MATERIAL AND WORKMANSHIP

The Pierce graphics fading and deterioration limited warranty limited warranty certificate, WA0168, is included with this proposal.

VEHICLE STABILITY CERTIFICATION

The fire apparatus manufacturer will provide a certification stating the apparatus complies with NFPA 1901, current edition, section 4.13, Vehicle Stability. The certification will be provided at the time of bid.

ENGINE INSTALLATION CERTIFICATION

The fire apparatus manufacturer will provide a certification, along with a letter from the engine manufacturer stating they approve of the engine installation in the bidder's chassis. The certification will be provided at the time of delivery.

POWER STEERING CERTIFICATION

The fire apparatus manufacturer will provide a certification stating the power steering system as installed meets the requirements of the component supplier. The certification will be provided at the time of bid.

CAB INTEGRITY CERTIFICATION

The fire apparatus manufacturer will provide a cab crash test certification with this proposal. The certification will state that a specimen representing the substantial structural configuration of the cab has been tested and certified by an independent third party test facility. Testing events will be documented with photographs, real-time and high-speed video, vehicle accelerometers, cart accelerometers, and a laser speed trap. The fire apparatus manufacturer will provide a state licensed professional engineer to witness and certify all testing events. Testing will meet or exceed the requirements below:

- SAE J2422 Cab Roof Strength Evaluation - Quasi-Static Loading Heavy Trucks.
- European Occupant Protection Standard ECE Regulation No.29.
- SAE J2420 COE Frontal Strength Evaluation - Dynamic Loading Heavy Trucks.

Side Impact

The cab will be subjected to dynamic preload where a 14,320-lb moving barrier is slammed into the side of the cab at 5.50 mph, striking with an impact of 13,000 ft-lb of force. This test is part of the SAE J2422 test procedure and more closely represents the forces a cab will see in a rollover incident.

Frontal Impact

The same cab will withstand a frontal impact of 32,600 ft-lb of force using a moving barrier in accordance with SAE J2420.

Additional Frontal Impact

The same cab will withstand a frontal impact of 65,098 ft-lb of force using a moving barrier. (Twice the force required by SAE J2420)

Roof Crush

The cab will be subjected to a roof crush force of 22,500 lb. This value meets the ECE 29 criteria, and is equivalent to the front axle rating up to a maximum of ten (10) metric tons.

Additional Roof Crush

The same cab will be subjected to a roof crush force of 110,000 lbs. (Four and a half times the load criteria of ECE 29)

The same cab will withstand all tests without any measurable intrusion into the survival space of the occupant area.

There will be no exception to any portion of the cab integrity certification. Nonconformance will lead to immediate rejection of bid.

CAB DOOR DURABILITY CERTIFICATION

Robust cab doors help protect occupants. Cab doors will survive a 200,000 cycle door slam test where the slamming force exceeds 20 G's of deceleration. The bidder will certify that the sample doors similar to those provided on the apparatus have been tested and have met these criteria without structural damage, latch malfunction, or significant component wear.

WINDSHIELD WIPER DURABILITY CERTIFICATION

Visibility during inclement weather is essential to safe apparatus performance. Windshield wipers will survive a 3 million cycle durability test in accordance with section 6.2 of SAE J198 *Windshield Wiper Systems - Trucks, Buses and Multipurpose Vehicles*. The bidder will certify that the wiper system design has been tested and that the wiper system has met these criteria.

SEAT BELT ANCHOR STRENGTH

Seat belt attachment strength is regulated by Federal Motor Vehicle Safety Standards and should be validated through testing. Each seat belt anchor design will withstand 3000 lb of pull on both the lap and shoulder belt in accordance with FMVSS 571.210 Seat Belt Assembly Anchorages. The bidder will certify that each anchor design was pull tested to the required force and met the appropriate criteria.

SEAT MOUNTING STRENGTH

Seat attachment strength is regulated by Federal Motor Vehicle Safety Standards and should be validated through testing. Each seat mounting design will be tested to withstand 20 G's of force in accordance with FMVSS 571.207 Seating Systems. The bidder will certify, at time of delivery, that each seat mount and cab structure design was pull tested to the required force and met the appropriate criteria.

PERFORMANCE CERTIFICATIONS

Cab Air Conditioning

Good cab air conditioning temperature and air flow performance keeps occupants comfortable, reduces humidity, and provides a climate for recuperation while at the scene. The cab air conditioning system will cool the cab from a heat-soaked condition at 100 degrees Fahrenheit to an average of 78 degrees Fahrenheit in 30 minutes. The bidder will certify that a substantially similar cab has been tested and has met these criteria.

Cab Defroster

Visibility during inclement weather is essential to safe apparatus performance. The defroster system will clear the required windshield zones in accordance with SAE J381 Windshield Defrosting Systems

Test Procedure And Performance Requirements - Trucks, Buses, And Multipurpose Vehicles. The bidder will certify that the defrost system design has been tested in a cold chamber and passes the SAE J381 criteria.

Cab Auxiliary Heater

Good cab heat performance and regulation provides a more effective working environment for personnel, whether in-transit, or at a scene. An auxiliary cab heater will warm the cab 77 degrees Fahrenheit from a cold-soak, within 30 minutes when tested using the coolant supply methods found in SAE J381. The bidder will certify, at time of delivery, that a substantially similar cab has been tested and has met these criteria.

AMP DRAW REPORT

The bidder will provide, at the time of bid and delivery, an itemized print out of the expected amp draw of the entire vehicle's electrical system.

The manufacturer of the apparatus will provide the following:

- Documentation of the electrical system performance tests.
- A written load analysis, which will include the following:
 - The nameplate rating of the alternator.
 - The alternator rating under the conditions specified per:
 - Applicable NFPA 1901 or 1906 (Current Edition).
 - The minimum continuous load of each component that is specified per:
 - Applicable NFPA 1901 or 1906 (Current Edition).
 - Additional loads that, when added to the minimum continuous load, determine the total connected load.
 - Each individual intermittent load.

All of the above listed items will be provided by the bidder per the applicable NFPA 1901 or 1906 (Current Edition).



Option List

11/10/2022

Customer: Nederland Fire Protection District
Representative Byrne, Jason
Organization: Front Range Fire Apparatus, Ltd
Requirements Manager:
Description: Nederland Saber 4x4 Engine 750 Gallon LHB
Body: Pumper, Medium, Aluminum, 2nd Gen, Saber
Chassis: Saber FR Chassis 4x4

Bid Number: 1177
Job Number:
Number of Units: 1
Bid Date: 03/28/2022
Stock Number:
Price Level: 43 (Current: 43)
Lane:

Line	Option	Type	Option Description	Qty
1	0074080		Build-to-Order, Pierce Florida Product - 2nd Gen Pumper	1
2	0766611		Boiler Plates, Pumper	1
			Fire Department/Customer - Nederland Fire Protection District	
			Operating/In conjunction W-Service Center - Operating	
			Miles - 50 Miles	
			Number of Fire Dept/Municipalities - 5	
			Bidder/Sales Organization - Front Range Fire Apparatus	
			Delivery - Delivery representative	
			Dealership/Sales Organization, Service - Front Range Fire Apparatus	
3	0661794		Single Source Compliance	1
4	0584455		Manufacture Location, Bradenton, Florida	1
5	0584453		RFP Location: Bradenton, Florida	1
6	0588609		Vehicle Destination, US	1
7	0610784		Comply NFPA 1901 Changes Effective Jan 1, 2016, With Exceptions	1
8	0533347		Pumper/Pumper with Aerial Device Fire Apparatus	1
9	0588611		Vehicle Certification, Pumper	1
10	0568412		Agency, Apparatus Certification, Pumper/Tanker, Third Party, PMFD	1
11	0000000	STF	Weekly Photo Reports - Pumper/Tanker	1
12	0056880		Requirements of Apparatus Manufacturer	1
13	0536644		Customer Service Website	1
14	0000113		Table of Contents	1
15	0620362		Consortium, HGAC	1
16	0537375		Unit of Measure, US Gallons	1
17	0030006		Bid Bond Not Requested	1
18	0807710		Performance Bond, 100% with 25% Warranty Bond, 1 Yr, and Payment Bond	1
19	0000007		Approval Drawing	1
20	0002928		Electrical Diagrams	1
21	0625274		Saber FR Chassis 4x4	1
22	0629024		Chassis Discount, Saber FR	1
23	0000110		Wheelbase	1
			Wheelbase - 177.5"	
24	0000070		GVW Rating	1
			GVW rating - 43,450 lbs	
25	0619391		Frame Rails, 10.25" x 3.50" x .375", Saber FR/Enf 4x4 Step Frame	1
26	0020018		Frame Liner Not Req'd	1
27	0737375	SP	Axle, Front, Marmon Herrington MT-22 19,450 lb, (FWD) Saber FR/Enforcer	1
28	0637913		Suspension, Front, Standens, Taper Leaf, 20,000 lb, Saber FR/Enforcer	1
29	0000321		Shock Absorbers on Front Axle, Monroe Magnum 65, Saber/Enforcer	1
30	0639612		Oil Seals Not Available, Front Drive Axle	1
31	0670337		Differential Lock, Driver Controlled, (DCDL), Marmon Herrington MT-22	1
32	0664491		Tires, Front, Michelin, XZU S2, 315/80R22.50, 20 ply	1
33	0789277		Wheels, Front, Accuride, 22.50" x 9.00", Steel, Hub Pilot, 315/80R, 5.25" Inset	1
34	0625013		Axle, Rear, Eaton 230S4, 4WD, 24,000 lbs, Saber FR/Enforcer	1
35	0544248		Top Speed of Vehicle, 63 MPH	1
36	0565379		Suspen, Rear, Single Slipper Spring, 24,000 lb, Saber/Enforcer	1
37	0000485		Oil Seals, Rear Axle	1
38	0011855		Differential Lock, (CTD) Eaton, Sngl Axle (4x4)	1
39	0070728		Tires, Rear, Michelin, XDN2, 12R22.50, 16 ply, Single	1
40	0654797		Wheels, Rear, Accuride, 22.50" x 9.00", Steel, Hub Pilot, Single	1
41	0568081		Tire Balancing, Counteract Beads	1

Line	Option	Type	Option Description	Qty
42	0627984		Tire Pressure Monitoring, RealWheels, AirSecure, Valve Cap, Front Tires Only Qty, Tire Pressure Ind - 2	1
43	0057936		Covers, Lug Nut, Chrome	1
44	0002045		Mud Flap, Front and Rear, Pierce Logo	1
45	0011930		Tire, "Crossfire" Air Pressure Equalization	1
46	0544802		Chocks, Wheel, SAC-44-E, Folding Qty, Pair - 01	1
47	0544806		Mounting Brackets, Chocks, SAC-44-E, Folding, Horizontal Qty, Pair - 01	1
48	0632611	SP	Location, Wheel Chocks - Left Side Rear Tire, Forward ESC/ABS/ATC Wabco Brake System, Single Rear Axle, 4x4 ABS, 4x2 ESC/ABS/ATC	1
49	0803249		Brakes, Bendix, ADB-22X, 17" Disc, Front (MT22 Axle)	1
50	0581433		Brakes, Bendix, Cam, Rear, 16.50 x 7.00"	1
51	0020784		Air Compressor, Brake, Cummins/Wabco 18.7 CFM	1
52	0637584		Brake Reservoirs, 5,376 Cubic Inch Minimum Capacity, Saber FR/Enforcer	1
53	0644228		Air Dryer, Wabco System Saver 1200 IWT, Heated, 10" Frame, Standen, SFR/Enf	1
54	0678701		Brake Lines, Nylon, Special Color	1
55	0089419		Air Inlet, with Kussmaul Air Eject (Fill-In Blank Location) Location - driver side step well (see drawing) Qty, Air Coupling (s) - 1	1
56	0000845		Air Tank, Additional for Extra Capacity	1
57	0630142		Moisture Ejectors, Automatic, w/Heat, All Tanks, Enforcer/Saber FR	1
58	0805875		Engine, Cummins L9, 450 hp, 1250 lb-ft, W/OBD, EPA 2024, Saber FR/Enforcer	1
59	0001244		High Idle w/Electronic Engine, Custom	1
60	0687994		Engine Brake, Jacobs Compression Brake, Cummins Engine Switch, Engine Brake - e) ISC/ISM/ISL9/ISX Hi Med Lo	1
61	0644227		Clutch, Fan, Air Actuated, Saber FR/Enforcer	1
62	0644573		Air Intake, Water & Ember Screen, Saber FR/Enforcer	1
63	0794761		Exhaust System, 4", 2017 L9 Engine, Horizontal, Right Side	1
64	0788765		Radiator, Saber FR/Enforcer	1
65	0001090		Cooling Hoses, Rubber	1
66	0051125		Fuel Tank, 75 Gallon, Left Side Fill, Qtm/AXT/Vel/Imp/DCF/SFR/Enf Finish - Brushed Stainless	1
67	0001129		Lines, Fuel	1
68	0618791		DEF Tank, 4.5 Gallon, DS Fill, Forward of Axle, Common Air Bottle Door	1
69	0723716		Fuel Priming Pump, Electronic, Automatic, Cummins, No Swt Req'd	1
70	0552712		Not Required, Shutoff Valve, Fuel Line	1
71	0699437		Cooler, Chassis Fuel, Not Req'd.	1
72	0690880		No Selection Required From This Category	1
73	0887559		Trans, Allison 6th Gen, 3000 EVS P, w/Prognostics, Imp/Vel/SFR/Enf	1
74	0625329		Transmission, Shifter, 5-Spd, Push Button, 3000 EVS	1
75	0684459		Transmission Oil Cooler, Modine, External	1
76	0024895		Mode, Downshift, Aggressive downshift to 2nd, w/engine brake, 5 speed	1
77	0001370		Driveline, Spicer 1710	1
78	0603370	SP	Driveline Reviewed & Approved	1
79	0637248		Steering, Dual Gear, TRW TAS-65, w/tilt, Pump w/ Cooler, Saber FR/Enforcer	1
80	0605356		Steering Wheel, 4 Spoke without Controls, Saber FR/Enforcer	1
81	0690274		Logo/Emblem, on Dash Text, Row (1) One - Nederland Text, Row (2) Two - Fire Text, Row (3) Three - District	1
82	0779369	SP	Crossmember, Special For PTO Pump Installation	1
83	0887571	SP	Winch, Superwinch, 18,000 lb. Fixed, Front, Tiger Shark, Model#1518001,Electric Stay arm, Tray Cover - b) Pneumatic Stay Arm	1
84	0776057	SP	Bumper, 16" Extended .38" Formed Steel, 10.38"H, Painted, Saber FR/Enforcer	1
85	0625558		No Selection Required, Cover Included with Tray/Tool Box Option	1
86	0614646		No Lift & Tow Package, Imp/Vel, AXT, SFR/Enf	1
87	0049964		Tow Eyes, Painted Black, Extended Out Front of Bumper	1
88	0625654		Cab, Saber FR, 6000	1
89	0647919		Engine Tunnel, ISL, Saber FR/Enforcer	1
90	0633594		Rear Wall, Interior, Adjustable Seating	1

Line	Option	Type	Option Description	Qty
91	0632103		Rear Wall, Exterior, Cab, Saber FR/Enforcer Material, Exterior Rear Wall - Painted	1
92	0644201		Cab Lift, Elec/Hyd, Saber FR/Enforcer	1
93	0636939		Grille, Polished Stainless Steel, Front of Cab, Saber	1
94	0647932		Not Required, Trim, S/S Band, Across Cab Face, AXT/Saber/Enforcer	1
95	0015440		No Chrome Molding, On side of cab	1
96	0521669		Mirrors, Retractable, West Coast Style, Htd/Rmt, w/Htd/Rmt Convex	1
97	0648171		Door, Half-Height, Saber FR/Enforcer 4-Door Cab, Level Roof Key Model, Cab Doors - 751 Cab, Exterior Door Handle, Finish - 4-Door, Chrome/Black	1
98	0655543		Door Panel, Brushed Stainless Steel, Saber/Enforcer 4-Door Cab	1
99	0528958		Not Required, Controls, Electric Window, AXT, Quantum, Saber, Enforcer, Dash CF	1
100	0633615		Steps, 4-Door Cab, Reduced Bottom Step, Saber FR/Enforcer Step Well Material - Aluminum Treadplate	1
101	0763659		Handrail, Exterior, Knurled, Alum, 4-Door Cab, AXT/SFR/Enf/Vel, 4x4	1
102	0743060	SP	Steps, Stirrup, Swing Style, Cab & Crew Cab Doors, AXT, Saber/Enf 4x4 Light, Step, Additional - P25 LED	1
103	0892638		Lights, Cab & Crw Cab Acs Stps, P25, LED w/Bezel, 6lts Color, Trim - Chrome Housing	1
104	0040475		Crowns, Front Fender, Rubber	1
105	0637984		Window, Side of C/C, Fixed, Saber FR/Enforcer	1
106	0644019		Holder, Cup, 4" Diameter x 4" High x 1" Slit on Side, Matting, Alum, Each Location - To be mounted at final inspection Qty, - 04	4
107	0722796		Dash, Poly, Saber FR/Enforcer	1
108	0607217		Mounting Provisions, 3/16" Alum, Full Engine Tunnel, Saber FR/Enforcer Mounting Provision Spacing - .75" Material Finish, Cab Interior - Painted	1
109	0657893		Mounting Plate, 3/16" Aluminum, Cab Interior Location - driver side interior rear cab wall (full area between cabinet and outer cab wall) Qty, - 01 Size - driver side interior rear cab wall (full area between cabinet and outer cab wall) Mounting Provision Spacing - .75" Material Finish, Cab Interior - Painted	1
110	0750824		Cab Interior, Vinyl Headliner, Saber FR/Enforcer, CARE Color, Cab Interior Vinyl/Fabric - Endure Vinyl - Black Engine Tunnel Cover - Painted Cab Interior Rear Wall Material - Painted Aluminum	1
111	0753903		Cab Interior, Paint Color, Saber FR/Enforcer Color, Cab Interior Paint - b) black	1
112	0052100		Floor, Rubber Padded, Cab & Crew Cab, Saber/Enforcer	1
113	0741237		HVAC, Saber FR, CARE HVAC System, Filter Access - Removable Panel Auxiliary Cab Heater - Both HVAC System, Control Loc. - Panel Position #12	1
114	0012122		Fans, Window Defrost, One (1) Fan on Each Side	1
115	0639675		Sun Visor, Smoked Lexan, AXT, Imp/Vel, Saber FR/Enforcer Sun Visor Retention - Thumb Latch	1
116	0634328		Grab Handles, Driver and Officer Door Posts, Saber FR/Enforcer	1
117	0002526		Light, Engine Compt, All Custom Chassis	1
118	0631830		Fluid Check Access, Saber FR/Enforcer, Arrow XT Latch, Door, Storage - Lift and Turn Latch	1
119	0530840		Box, Storage, Aluminum, Latex Gloves Location - to be mounted at final inspection Qty, - 04	4
120	0660939		Map Box, 2 Bin, 30 Degree Slant Location - to be mounted at final inspection	1
121	0583042		Side Roll and Frontal Impact Protection	1
122	0622619		Seating Capacity, 4 Seats	1
123	0636955		Seat, Driver, Pierce PSV, Air Ride, High Back, Safety, Saber FR/Enforcer	1
124	0636942		Seat, Officer, Pierce PSV, Fixed, SCBA, Safety, Saber FR/Enforcer	1

Line	Option	Type	Option Description	Qty
125	0620420		Radio Compartment, Below Non-Air Ride Seat, Saber FR/Enforcer Latch, Door, Storage - Lift and Turn Latch, Flush	1
126	0635973		Seat, Rear Facing C/C, DS Outboard, Pierce PSV, SCBA, Safety, Saber FR/Enforcer	1
127	0102783		Not Required, Seat, Rr Facing C/C, Center	1
128	0635969		Seat, Rear Facing C/C, PS Outboard, Pierce PSV, SCBA, Safety, Saber FR/Enforcer	1
129	0108189		Not Required, Seat, Forward Facing C/C, DS Outboard	1
130	0785367		Cabinet, Forward Facing, Center, 38.50 W x 50 H x 18 D, Roll, SFR/Enf Material Finish, Shelf - Painted - Cab Interior Shelf/Tray, Cabinet - (2) Shelves, Adjustable, 1.25" Up-Turned Lip Door, Cab Interior Cabinet - Rollup, Amdor, White, Non-Locking Light, Tall Cabinet - Pierce, Interior, Left Side and Pierce, Interior, Right Side Louvers, Cabinet - 0-No Louvers	1
131	0108190		Not Required, Seat, Forward Facing C/C, PS Outboard	1
132	0617401		Matting, Turtle Tile, No Trim, EMS Compt Location - each shelf and floor of ems compartment Qty, - 03 Color - 1) black	3
133	0566653		Upholstery, Seats In Cab, Turnout Tuff Color, Cab Interior Vinyl/Fabric - c) Black	1
134	0543991		Bracket, Air Bottle, Hands-Free II, Cab Seats Qty, - 03	3
135	0603866		Seat Belt, Dual Retractor, ReadyReach, Saber FR/Enforcer Seat Belt Color - Red	1
136	0602464		Helmet Storage, Provided by Fire Department, NFPA 2016	1
137	0647647		Lights, Dome, FRP Dual LED 4 Lts Color, Dome Lt - Red & White Color, Dome Lt Bzl - Grey Control, Dome Lt White - Door Switches and Lens Switch Control, Dome Lt Color - Lens Switch	1
138	0755334	SP	Handlts, (3) Streamlight, Vulcan 180, 44315, 12v, Orange Location, Portable Hand Light - At Pickup	1
139	0681751		Handlight, Streamlight, E- Flood LiteBox, 45805 LED, 12v Charger, Orange Qty, Lights - 02 Location, Lights - TBD	2
140	0644187		Cab Instruments, Black Gauges, Black Bezels, Saber FR/Enforcer Emergency Switching - Individual Switches	1
141	0002544		Air Restriction Indicator - Pierce Chassis	1
142	0543751		Light, Do Not Move Apparatus Alarm, Do Not Move Truck - Pulsing Alarm	1
143	0637359		Not Required, Door Open Indicator w/Do Not Move Truck Light, Enf/Saber FR	1
144	0754774		Switching, Cab Instrument Lower Console & Overhead, Rocker, Saber	1
145	0802940		Wiper Control, 2-Speed with Intermittent, Saber FR/Enforcer Location, Wiper Control - Standard Location	1
146	0797189		Wiring, Spare, 4.8 A 12V DC, USB Termination Blue Sea 1045 1st Qty, - 02 12vdc power from - Battery direct Location - TBD	2
147	0636439		Wiring, Spare, 37.5 A 12V DC, Cust Install Radio, 30A Bat Dir, 7.5A Ign & Grnd Qty, - 02 Location - center dash switch panel	2
148	0579886		Wiring, Spare, 50 A 12V DC, 6 Circuit Fuse Block, Blue Sea 5025 1st Qty, - 03 12vdc power from - Battery direct Location - Med cabinet centered up high, behind officer seat, in cabinet TBD	3
149	0763646		Vehicle Information Center, LCD On Gauge Cluster Only, Sab/Enf System Of Measurement - US Customary	1
150	0734857		Collision Mitigation, HAAS Alert (R2V), HA5 Subscription, HAAS R2V - R2V - 5 Year Data Plan Subscription	1
151	0610240		Vehicle Data Recorder w/Seat Belt Monitor	1

Line	Option	Type	Option Description	Qty
152	0735095		Intercom, David Clark, 4-Pos, 2-Dual Radio, (D, O, RPTT), 2obC, 3805 Location - TBD	1
153	0637058		David Clark Universal Radio Interfaces Included with Single/Dual System Location, Intercom, C Cab - 2) 2 rearward facing seats	1
154	0597914		Headset, David Clark, H3442 Under Helmet, Flex Mic Qty, - 02 Location - front seats	2
155	0589947		Headset, David Clark, H3432 Over The Head, Flex Mic, Push On Push Off Qty, - 02 Location - rear seats	2
156	0681408		Hangers For Headsets, NFPA, Each Qty, - 05 Location, Headset Hangers - Driver Seat, Officer Seat, DS Outbrd, Fwrd Fcng Seat, PS Outbrd, Fwrd Fcng Seat and Rear, Center, Fwrd Fcng Seat	5
157	0696439		Antenna Mount, Custom Chassis, Cable Routed to Instrument Panel Area Qty, - 02 Location, Antenna Mount - Left And Right Side	2
158	0808066		Camera, Pierce, 7" HD, R, RS, LS Cameras, AHD Color - 1) black Location, Camera Monitor - Driver Side Dash	1
159	0511071		Guard, 4-Way, Rear Vision Camera Qty, - 01 Location - center rear	1
160	0624249		Electrical Power/Signal Protection & Control, Saber FR	1
161	0624260		Electrical System, Saber FR	1
162	0079166		Batteries, (4) Exide Grp 31, 950 CCA ea, Threaded Stud	1
163	0008621		Battery System, Single Start, All Custom Chassis	1
164	0002698		Battery Compartment, Saber/Enforcer	1
165	0531315		Charger, Sngl Sys, IOTA, DSL-75, 75 Amp, Kussmaul 091-94-12 Ind, Qtm/Enf/SFR	1
166	0662220		Location, Charger, Cab Behind Driver Seat, Dash CF/Saber FR/Enf	1
167	0536099		Location, Bat Chrg Ind, Driver's Step Area	1
168	0782026		Shoreline, 20A 120V, Blue Sea Sure Eject 7851 Qty, - 01 Connection, Shoreline - charger / shoreline Color, Cover, BI Sea Inlet - Red	1
169	0026800		Shoreline Location Location, Shoreline(s) - DS Seat Riser	1
170	0009429		Electric Power Only, Portable Winch Location - rear receiver hitch Qty, Receptacles - 01	1
171	0647729		Alternator, 320 amp, Delco Remy 40SI	1
172	0644176		Load Manager, Integrated In Electrical System, Saber FR/Enforcer	1
173	0888792	SP	Headlights, Rect LED, 4X4, JW Spkr Evo 2, Heat, Saber Color, Headlight Bez - Chrome Bezel	1
174	0802935		Light, Directional, WIn M62T* LED, Cmn Bzl, Above Headlights, Sab/Enf Color, Lens, LED's - Clear Color, Q Bezel and Trim - Polished Chrome Flash Pattern, Directional Lts - Sequence (Slow) to Solid - Steady On	1
175	0620054		Light, Directional/Marker, Intermediate, Weldon 9186-8580-29 LED 2lts	1
176	0647802		Lights, Clearance/Marker/ID, Front, P25 LED 5 Lts, Saber FR/Enforcer	1
177	0647899		Lights, Directional/Marker, Cab Front Side, Weldon 9186-8580-29 LED, Sab/Enf	1
178	0563675		Lights, Clearance/Marker/ID, Rear, Truck-Lite 33050R LED 7Lts	1
179	0804514		Lights, Tail, WIn M62BTT* Red Stop/Tail & M62T* Amber Dir Arw For Hsg Color, Lens, LED's - Clear Flash Pattern, Directional Lts - Sequence (Slow) to Solid - Steady On	1
180	0806466		Lights, Backup, WIn M62BU, LED, For Tail Lt Housing	1
181	0889577		Bracket, License Plate & Light, P25 LED, Stainless Brkt Color, Trim - Chrome Housing	1
182	0556842		Bezels, WIn, (2) M6 Chrome Pierce, For mtg (4) WIn M6 lights	1
183	0589905		Alarm, Back-up Warning, PRECO 1040	1
184	0565826	SP	Switch, Back-Up Alarm Override	1
185	0769569		Lights, Perimeter Cab, Amdor AY-LB-12HW012 LED 4Dr	1

Line	Option	Type	Option Description	Qty
186	0769559		Lights, Perimeter Pump House, Amdor AY-LB-12HW012 LED 2lts	1
187	0769560		Lights, Perimeter Body, Amdor AY-LB-12HW012 LED 2lts, Rear Step	1
			Control, Perimeter Lts - DS Switch Panel, Parking Brake Applied and Directional Light Activation	
188	0769567		Lights, Perimeter, Amdor AY-LB-12HW012 12", Brkt	6
			Qty, Lights - 06	
			Location, Additional Perimeter Lights - Each Side Under Front Bumper, 2lts, Under Compt LS1, 1lt, Under Compt LS3, 1lt, Under Compt RS1, 1lt and Under Compt RS3, 1lt	
189	0556337		Lights, Step, P25 LED at Rear Tailboard, 2lts Perm Lts	1
190	0790483		Light, Visor, HiViz, FT-MB-33-*-* , 42.44" long	1
			Qty, - 01	
			Location, driver's/passenger's/center - Centered	
			Control, Scene Lts - Cab Sw Panel DS, Pump Panel Sw LS and Cab Sw Panel PS	
			Color, Lt Housing HiViz - Job Color	
			Scene Light Optics - Flood/Spot	
191	0889855		Lights, HiViz FT-B-46-*-* , 46", Brkt Fet 1st	1
			Location - driver side cab centered above cab canopy window	
			Qty, - 1	
			Control, Scene Lts - Cab Sw Panel DS, Pump Panel Sw LS and Cab Sw Panel PS	
			Color, Lt Housing HiViz - Black	
			Brackets, Cab Side Scene Lts - 30 Deg Angled Brkt Off Cab Roof	
192	0889852		Lights, HiViz FT-B-46-*-* , 46", Brkt Fet 2nd	1
			Location - officer side cab centered above cab canopy window	
			Qty, - 1	
			Control, Scene Lts - Cab Sw Panel DS, Pump Panel Sw LS and Cab Sw Panel PS	
			Color, Lt Housing HiViz - Black	
			Brackets, Cab Side Scene Lts - 30 Deg Angled Brkt Off Cab Roof	
193	0773358		Lights, HiViz FT-B-46-*-* LED, 2nd	1
			Location - driver side body centered recessed	
			Qty, - 01	
			Control, Scene Lts - DS Scene Lts	
			Color, Lt Housing HiViz - Black	
194	0773109		Lights, HiViz FT-B-46-*-* LED, 3rd	1
			Location - officer side body centered	
			Qty, - 01	
			Control, Scene Lts - PS Scene Lts	
			Color, Lt Housing HiViz - Black	
195	0774296		Housing, Recessed Light, Horizontal Mt	1
			Location - driver side body scene light	
			Qty, - 1	
			Material, Bracket - Painted Aluminum	
196	0773362		Lights, HiViz FT-B-46-*-* LED, 1st	1
			Location - on cross bar of hard hose bed cover, centered	
			Qty, - 01	
			Control, Scene Lts - Cab Sw Panel DS, Pump Panel Sw LS, Cab Sw Panel PS, Body Switch, DS Rear Bulkhead and Reverse Signal with Emaster Side	
			Color, Lt Housing HiViz - Black	
197	0532358		Not Required, Deck Lights, Other Hose Bed & Rear Lighting	1
198	0645877		Lights, Hose Bed, Sides, Dual LED Light Strips	1
			Control, Hose Bed Lts - Cup Switch At Rear	
199	0645677		Lights, Not Required, Rear Work, Alt. 12 Volt Lights At Rear Body	1
200	0768376		Lights, Walk Surf, FRP Flood, LED, Qty, Loc Fet	2
			Location - on one hose bed cover, one on dunnage area, see drawing	
			Qty, Surface Lights - 2	
201	0753285		Switch, White Warning Lights, Front	1
			Function Reset - On	
202	0590751		Switch, Red, IPOS	1
			Location - emergency master	
			Qty, - 01	
			Fill in Blank - emergency master	

Line	Option	Type	Option Description	Qty
203	0802863		Pumper, Medium, Aluminum, 2nd Gen, Saber	1
204	0632361		No Additional Florida Discount - w/Saber FR Chassis	1
205	0554271		Body Skirt Height, 20"	1
206	0780858	SP	Tank, Water, 750 Gallon, Poly, Med, New York Style, 4x4	1
207	0003405		Overflow, 4.00" Water Tank, Poly	1
208	0028104		Foam Cell Required	1
209	0083450		Notch, Poly Tank, Location	2
			Location - for both the foam pump and the generator, see drawing	
			Qty, - 02	
210	0633066		Sleeve, Through Tank	1
			Qty, Sleeve - 1	
			Water Tank Sleeve - Plumbing/Hydraulic Diameter - 3" Plumbing	
211	0553725		Restraint, Water Tank, Heavy Duty, Special Type Tank, 4x4, or Export	1
212	0003429		Not Required, Direct Tank Fill	1
213	0003424		Not Required, Dump Valve	1
214	0048710		Not Required, Jet Assist	1
215	0030007		Not Required, Dump Valve Chute	1
216	0514778		Not Required, Switch, Tank Dump Master	1
217	0556223		Hose Bed, Aluminum, Pumper, New York Style, Fill In Blank Height, Painted	1
			Fill in Blank - 68"	
			Material Trim/Scuffplate - b) S/S, Brushed	
218	0723549		Painted Hose Bed	1
			Paint Color, Hose Bed Interior - Match Lower Body	
219	0003481		Hose Bed Capacity, Special	1
			Capacity, Hosebed - Left to right,	
			#1: 400' of 3" DJ	
			#2: 400' of 3" DJ	
			#3: 1000' of 5"	
			#4: 250' of 2.5" DJ	
			#5: 200' of 1.75" DJ Single Stack	
220	0083488		Divider, Hose Bed, .25" Unpainted	4
			Qty, Hosebed Dividers - 4	
221	0010133		Cross-Divider, Hose Bed	1
222	0089471		Cutout, Handhold, in Hose Bed Divider	4
			Qty, - 04	
223	0663562		Hose Bed Floor, Reinforced, Generator Mounting	1
224	0689727		Cover, Hose Bed, Alum Treadplate, No Dome Access	1
225	0538045		Flap, Rear of Alum Hose Bed Cover, Vinyl, Paddle Seat Belt Buckles	1
			Color, Vinyl Cover - a) red	
226	0680205		Running Boards, 14.75" Deep	1
227	0689497		Tailboard, T-Shaped, 24" & 8" Deep, Angled Corners	1
228	0690037		Wall, Rear, Smooth Aluminum/Body Material	1
			Material, Rear Wall Inboard Facing Surfaces - Aluminum Diamondplate	
229	0889721		Tow Eyes, w/Hitch Receiver, 2G Pumper	1
			Connection, Trailer/12V Electrical, 2G - No Electric Connection	
230	0777391		Hose Restraint, Running Board, Velcro Straps, Strap Location	1
			Location - for water can TBD	
			Location, Hose Tray, Running Board - Right Side	
			Qty, Tray, Hose - 1	
231	0590926		Hose Restraint, Running Board, Velcro Straps	2
			Location, Hose Tray, Running Board - a) both sides	
			Qty, Tray, Hose - 2	
232	0079470		Tray, Hose, Running Board, "Free Floating", w/Capacity Feature	2
			Location, Hose Tray, Running Board - a) both sides	
			Qty, Tray, Hose - 2	
			Capacity, Hose Tray - 25' of 5" LDH driver side, 50' of 2.5" DJ on officer side	
233	0602109	SP	Bin, Extinguisher, Running Board, 8" Diameter/8" Deep	1
			Location - officer side running board forward	
			Qty, - 01	
234	0895820		Construction, Compt, Alum, 2G Pumper	1
235	0531188		LS 152" Rollup, Full Height Front & Rear, FDLER, Raised Rear 6"	1
236	0887574	SP	RS 152" Rollup, 3/4 Height Front Rear, (1) Lap Broom, FDLER, Raised Rear 6"	1

Line	Option	Type	Option Description	Qty
237	0692733		Doors, Rollup, Gortite, Side Compartments Qty, Door Accessory - 05 Color, Roll-up Door, Gortite - Painted to Match Lower Body Latch, Roll-up Door, Gortite - Non-Locking Liftbar	5
238	0013671		Compt, Rear, Rollup, 30.75" FF, 25.88" D	1
239	0692746		Door, Gortite, Rollup, Rear Compartment Color, Roll-up Door, Gortite - Painted to Match Lower Body Latch, Roll-up Door, Gortite - Non-Locking Liftbar	1
240	0555146		Pull Strap, Body Doors, Each Qty, Door Accessory - 03 Location, Door Pull Strap - LS1, LS2 and LS3	3
241	0554995		No Body Modification Required	1
242	0786048	SP	Scuffplate, Rear Bulkhead, Brushed Stainless Steel, Special Size Location - under pike pole heads on rear bulkhead officer to protect from pike heads Qty, Scuffplates - 02 Size - TBD	2
243	0045159		Guard, Drip Pan, S/S, L-Shape, Cover Bottom and Rear of Rollup Door Roll Qty, Door Accessory - 06 Location, Door Accessory - all roll up compartment doors	6
244	0654498		Trim, Rollup Door, Painted Job Color, by Gortite Qty, - 06	6
245	0616670		Lights, Compt, Pierce LED, Dual Light Strips, Each Side of Door, Pumper/Tanker Qty, - 07 Location, Compartment Lights - All Body Compts	7
246	0687135		Shelf Tracks, Unpainted Qty, Shelf Track - 05 Location, Shelf Track - LS1, LS2, LS3, RS1 and RS3	5
247	0600350		Shelves, Adj, 500 lb Capacity, Full Width/Depth, Predefined Locations Qty, Shelf - 08 Material Finish, Shelf - Painted - Spatter Gray Location, Shelves/Trays, Predefined - .Location To Be Determined	8
248	0647091		Tray, Floor Mounted, Slide-Out, 500lb, 2.00" Sides Qty, - 02 Location, Tray Slide-Out, Floor Mounted - LS1 and B1 Material Finish, Tray - Painted - Spatter Gray	2
249	0726441		Partition, Trans Rear Compt Qty, Partition - 02 Location, Partition - c) both sides Material Finish, Partition - Painted - Spatter Gray	2
250	0635915		Mounting Plate, 3/16" Alum Location - in LS2 back wall and RS2 back wall Qty, - 02 Finish - Painted, Compt Interior, Spatter Gray Dimensions - entire back wall of each compartment	2
251	0659383		Matting, Turtle Tile w/Ramp, Compt Floors Location - LS2, LS3, RS1, RS2, RS3 Qty, Comp. Accessory - 05 Color - 1) black Color, Tile Edge - black	5
252	0028026		Matting, Turtle Tile, Compt Shelving only Location - all shelves and trays Qty, Shelf - 10 Color - 1) black	10
253	0004016		Rub Rail, Aluminum Extruded, Side of Body	1
254	0784809		Fender Crowns, Rear, Rubber, w/Removable Liner Material Finish, Fender Liner - Brushed Stainless	1
254	0000000	STF	Hose, Hard Suction, 5.00", 10.00', Clear Corrugated PVC, Kochek, FRFA Qty, Hard Suction Hose - 2	2
255	0613264		Compt, HSH, (2), Top of Body Compt, Stacked Qty, - 01 Location, Hose Trough/Compartment - a) left side Door, Material & Finish, Storage - Smooth Aluminum Latch, Door, Storage - "D" Handle Latch	1

Line	Option	Type	Option Description	Qty
255			Hinge Location - Left Side Trough, Material - Aluminum (2) Length of Compartment, HSH - Full Body Length Compartment Material, HSH - Same Material as Body with Treadplate	
256	0626229		Handrails, Side Pump Panels, Per Print	1
257	0004126		Handrails, Beavertail, Standard	1
258	0617842		Handrail, Rear, Below Hose Bed, Underside Handrail Mounting	1
259	0636301		Compt, Extinguisher (2) Fender Panel, Triangular Door Location, Bracket/comp. - Passenger side forward Qty, - 1 Door Finish, Fender Compt - Brushed Latch, Air Bottle Compt - Southco C2 Chrome Raised Insert, Air Bottle Compt - Rubber Matting	1
260	0648325		Compt, Air Bottle, Double, Tri Door, Fender Panel Qty, Air Bottle Comp - 2 Door Finish, Fender Compt - Brushed Location, Fender Compt - Double - LS Fwd - DEF Combo and Double - LS Rear - Fuel Combo Latch, Air Bottle Compt - Southco C2 Chrome Raised Insert, Air Bottle Compt - W-Shaped Insert	2
261	0657522		Compt, Air Bottle, Triple, Fender Panel Qty, Air Bottle Comp - 1 Door Finish, Fender Compt - Brushed Location, Fender Compt - Triple - RS Rear Latch, Air Bottle Compt - Southco C2 Chrome Raised Insert, Air Bottle Compt - Rubber Matting	1
261	0000000	STF	Ladder, 24' Duo-Safety 900A 2-Sect, Provided By FRFA	1
261	0000000	STF	Ladder, 14' Duo-Safety 775-DR Roof, Provided By FRFA Qty, - 01	1
262	0663471		Rack, Zico Quic-Lift, Side Sheet Mount Location, driver's/passenger's/center - Right	1
263	0089550		Brkt, for 10' Folding Ladder Storage on HLR	1
263	0000000	STF	Ladder, Folding, 10' 585A, Duo-Safety (NO MOUNT) Provided By FRFA	1
263	0000000	STF	Pike Pole, 4' Fire Hooks Unlimited, New York Roof Hook, Steel, Pry End, RH-4 Location - on back of cab Qty, Pike Poles - 1	1
263	0000000	STF	Pike Pole, 8' Fire Hooks Unlimited, New York Roof Hook, Steel, Pry End, RH-8 Location - in tube on top of officer side body Qty, Pike Poles - 1	1
263	0000000	STF	Pike Pole, 8' Fire Hooks Unlimited, Steel, Colorado Hook Location - TBD Qty, Pike Poles - 1	1
263	0000000	STF	Pike Pole, 10' Fire Hooks Unlimited, New York Roof Hook, Steel, RH-10, Pry End Qty, - 1 Location - in tube on top of officer side body	1
263	0000000	STF	Pike Pole, 6' Fire Hooks Unlimited, New York Roof Hook, Steel, Pry End, RH-6 Qty, - 02 Location - back of cab mounting, in tube on top of officer side body	2
264	0058193		Tubes, Alum, Pike Pole Storage, Spcl Notch, NY PP Head Location - on top of officer side body Qty, Pike Pole Tubes - 03	3
265	0673579		Mounting Bracket, Pike Pole, PAC Handlelok #1004, Ea Location - top of driver side body (for CO Hook) Qty, - 02	2
266	0724839	SP	Mounting Brackets, Pike Pole, Fire Hooks Unlimited, Hooks Nest 4/PAC Handlelok Location - back of cab each side (set for 4' NY, so they can store a 4' or a 6') Qty, - 02	2
267	0785102		Steps, Folding, Front of Body, Cargo Bed Access, w/LED, Trident Coating, Step - black Location, Steps - Full Height Left Side w/LED Light	1
268	0592994		Steps, Folding, Rear of Body, w/LED, Trident Coating, Step - black	1
269	0596127		Step Package, Body, w/4x4 Chassis, Not Required, Non-NFPA 2016 Compliant	1

Line	Option	Type	Option Description	Qty
270	0020500		Step, Camper Style, 8.00" Deep, Pull-out & Drop Down, 26" Wide Location, Additional Step - rear bumper Qty, Pullout Step - 02	2
271	0650260		I Zone Bracket, Pair, Wildland Style Fill in Blank - (1) each side on the rear of the body as shown on the AD	1
272	0019940		Step, Spcl Width, Rear Of Body, 8"	1
273	0007575		Pump House, Side Control, 48", Control Zone	1
274	0035500		Raised Pump House Structure, Side Control	1
275	0646289	SP	Pump, Waterous, CMPA, 1250 GPM, Two Stage, PTO	1
276	0004482		Seal, Mechanical, Waterous	1
277	0690873		Trans, Pump, Waterous, "PA" Series, Heavy Duty PTO	1
278	0603731		Pumping Mode, Stationary and Pump in Motion (Pressure Gauge in Cab Included)	1
279	0535276		Pump Shift, PTO Pump	1
280	0581602		Transmission Lock-up, Not Req'd, PTO Pump	1
281	0004547		Auxiliary Cooling System	1
282	0004484		Transfer Valve, Manual, Waterous	1
283	0746508		Valve(s), Relief Intake, Trident Air Max, Control Location Qty - 1 Pressure Setting - 125 psig	1
284	0721606		Intake Relief Valve Control - Behind Right Side Pump Panel Controller, Pressure, Pierce LCD, Metric, Custom Chassis Pressure Governor Throttle Control - Clockwise Pressure Governor Default Mode - Pressure Setting	1
285	0072176		Primer, Trident, Air Prime, Air operated, w/(2) Additional Priming Valves Inlet Extra Primer - LS & RS Main	1
286	0004457		Air Blowout, Plumbed to Pump	1
287	0044552		Line, 0.50" Recirculating w/Check Valve	1
288	0658368		Thermal Relief Valve, OPM, w/Red Warning Light, Waterous Pump Location, Thermal Relief Discharge - Ground	1
289	0780364		Manuals, Pump, (2) Total, Electronic Copies	1
290	0648463		Pump Test, Third Party, Rated at Special Elevation Flow Rate - 1250 GPM Elevation - 8250'	1
291	0602509		Plumbing, Stainless Steel and Hose, Two Stage Pump, Control Zone	1
292	0795135		Plumbing, Stainless Steel, w/Foam System	1
293	0004645		Inlets, 6.00" - 1250 GPM or Larger Pump	1
294	0767389		Valve, w/Relief, Right Inlet, 6", Akron 9333 Elec Controller, Jamesbury, Override Qty, Main Inlet Valves - 1	1
295	0767397		Valve, w/Relief, Left Inlet, 6", Akron 9333 Elec Controller, Jamesbury, Override	1
296	0602448		Cap, Main Pump Inlet, Provided by Fire Department, NFPA 2016	1
297	0084610		Valves, Akron 8000 series- All	1
298	0016158		Valve, Inlet(s) Recessed, Side Cntrl, "Control Zone" Qty, Inlets - 2	2
299	0004700		Control, Inlet, at Valve	1
300	0004660		Inlet (1), Left Side, 2.50"	1
301	0004680		Inlet, Right Side, 2.50"	1
302	0505132		Anode, Zinc, Pair, Pump, One (1) on Inlet Side & One (1) on Discharge Side	1
303	0092569		No Rear Inlet (Large Dia) Requested	1
304	0064116		No Rear Inlet Actuation Required	1
305	0092696		Not Required, Cap, Rear Inlet	1
306	0009648		No Rear Intake Relief Valve Required on Rear Inlet	1
307	0638634		Elbow, Front Inlet, 6" (FNST) x 5" Storz, w/ Storz Cap	1
308	0041254		Elbow, Rear Inlet, 6" (FNST) x 5" Storz, w/ Storz Cap	1
309	0092568		No Rear Auxiliary Inlet Requested	1
310	0723049		Valve, .75" Bleeder, Aux. Side Inlet, "T" Swing Handle	1
311	0786027	SP	(1) 4.00" Tank to Pump, Air Control, Cab & Pump Panel	1
312	0661594	SP	Outlet, Tank Fill, 1.50", Electric/Air, Locking Toggle Control	1
313	0062133		Control, Outlets, Manual, Pierce HW if applicable	1
314	0004940		Outlet, Left Side, 2.50" Qty, Discharges - 01	1
315	0005091		Elbow, Left Side Outlets, 45 Degree, 2.50" FNST x 2.50" MNST, VLH	1
316	0092570		Not Required, Outlets, Left Side Additional	1

Line	Option	Type	Option Description	Qty
317	0035094		Not Required, Elbow, Left Side Outlets, Additional	1
318	0004945		Outlet, Right Side, 2.50"	1
			Qty, Discharges - 01	
319	0025091		Elbow, Right Side Outlets, 45 Degree, 2.50" FNST x 2.50" MNST, VLH	1
320	0550252		Outlet, Right Side, 4" w/3" Plumbing, Handwheel Control, (added)	1
320	0000000	STF	Elbow, Right Side Outlets, 30 Degree, 4.00" FNST x 5.00" Storz, With Cap, FRFA	1
321	0029137		Not Required, Outlet, Large Diameter	1
322	0007308		Not Required, Elbow, Large Diameter Outlet	1
323	0092572		Not Required, Outlet, Front	1
324	0626292		Not Required, Outlet, Front, Additional & Accessories	1
325	0004995		Outlet, Rear, 2.50"	3
			Qty, Discharges - 03	
			Location, Outlet - e) 2 pass side, 1 driver side	
326	0045091		Elbow, Rear Outlets, 45 Degree, 2.50" FNST x 2.50" MNST, VLH	1
327	0092574		Not Required, Outlet, Rear, Additional	1
328	0085695		Not Required, Elbow, Rear Outlets, Large, Additional	1
329	0092573		Not Required, Outlet, Hose Bed/Running Board Tray	1
330	0752097		Caps/Plugs for 1.00" to 3.00" Discharges/Inlets, Chain	1
331	0723042		Valve, 0.75" Bleeder, Discharges, "T" Swing Handle	1
332	0005065		Outlet, 3.00" Deluge Riser	1
333	0095958		Deluge Outlet, Special Height/Location	1
			Fill in Blank - rearward centered in dunnage pan see drawing	
333	0000000	STF	Monitor, TFT Xfire XFC-52, (2) 2.5" Inlets, Package	1
			Monitor Finish - Painted by OEM	
334	0029304		No Nozzle Req'd	1
335	0015072		Deluge Mount, For TFT Crossfire Monitor, XFF-APL, No extend-a-gun	1
336	0723726		Speedlay Module Not Required	1
337	0722432		Hose Restraint Not Required, No Speedlay Module	1
338	0723395		Speedlays, Not Required	1
339	0723394		Speedlays, Not Required	1
340	0761773	SP	Crosslay(s), 1.50" Single Stack, w/Side Outlets Below, with Alum Trays	2
			Capacity, Special Xlay - 200' of 1.75" hose	
			Qty, Crosslays - 2	
341	0029196		Not Required, 2.50" Crosslay	1
342	0759415	SP	Hose Restraint, Crosslay/Deadlay, Vinyl, Seatbelt Low, Each Side, Ends	2
			Color, Vinyl Cover - a) red	
			Qty, - 02	
			Restraint Location - Bottom (towards the ground)	
343	0029260		Not Required, Speedlays	1
344	0750536		Hose Restr, Spdly, Not Required, No Spdly	1
345	0793101	SP	Cover, Crosslay, Bi-fold 3/16" Alum Treadplate, #30369	1
346	0019853		Crosslays, 8.00" Lower Than Standard - Control Zone w/9.00" Raised PH	1
347	0887784	SP	Reel, Booster, Steel - Over Pump, Left Side, 2/3 H.P. Motor, NPSH Fitting	1
			Finish, Reel - Painted Gray	
348	0005280		Switches, Reel Rewind - (1) Each Pump Panel	1
349	0018394		Hose, Booster - 150' of 1.00"/800 PSI, 1" NPSH Coupling	1
350	0005244		Capacity, Hose Reel 200' of 1"	1
351	0007428		Nozzle for Booster Reel Not Req'd	1
352	0005326		Blowout, Hose Reel - Valve at Panel	1
			Qty, - 1	
353	0622237		Roller Assembly, Additional	1
			Location - officer side top of pump house (to mirror driver side)	
			Qty, - 1	
354	0047283		Cover, Reel Motor Solenoid & Wiring	1
355	0624939		Foam Sys, Husky 3, Single Agent, Multi Select Feature	1
			Discharge, Foam Locations - Hose Reel in Dunnage Left Side, Rear	
			Outlet Left Side, Crosslay Front, Crosslay Rear, Rear Outlet Inboard Left Side	
			and Rear Outlet Inboard Right Side	
356	0012126		Not Required, CAF Compressor	1
357	0592527		Refill, Foam Tank, Integral, Husky 3	1
358	0031896		Demonstration, Foam System, Dealer Provided	1

Line	Option	Type	Option Description	Qty
359	0022539		Foam Cell, 20 Gallon, Reduce Water	1
			Type of Foam - Class "A"	
360	0697589		Drain, 1.00", Foam Tank #1, Husky 3 Foam System, Quarter Turn	1
361	0091079		Not Required, Foam Tank #2	1
362	0091112		Not Required, Foam Tank #2 Drain	1
363	0737117		Drawing, Pump Operator's Panel, Side Control, Left Side, PMFD	1
364	0032479		Pump Panel Configuration, Control Zone	1
365	0635355		Material, Pump Panels, Side Control Painted FormCoat Black	1
			Material Finish, Pump Panel, Side Control - Painted FormCoat Black	
			Material, Pump Panel, Side Control - Aluminum	
366	0723311		Panel, Pump Access, Right Side and Front, Side Control	1
			Door, Material & Finish, Access - aluminum treadplate	
			Latch, Pump Panel Access, Side Mount - Flush Lift and Turn, Chrome	
367	0005945		Light, Pump Compt	1
368	0586382		Gauges, Engine, Included With Pressure Controller	1
369	0005601		Throttle, Engine, Incl'd w/Press Controller	1
370	0739224		Indicator Light @ Pump Panel, Throttle Ready, Incl w/Pressure Gov/Throttle,Green	1
371	0549333		Indicators, Engine, Included with Pressure Controller	1
372	0745568		Indicator Light, Pump Panel, Ok To Pump, Green	1
373	0553643		Control, Air Horn at Pmp Pnl, Red Switch	1
374	0007518		Drains, Below Running Boards, LS, RS	1
375	0741057		Heater, Gauge, IC, Including Master Gauges, Test Port and Press Trans	1
376	0005748		Heater, Hot Water, 33,000 BTU	1
377	0769932		Seal, Rubber, Pump Panel Openings	1
378	0005689		Gauges, 4.50" Master, Class 1, 30"-0-600psi	1
379	0005714		Gauge, 2.50" Pressure, Class 1, 0-400psi	1
380	0739749		Gauge, Water Level, Pierce, In pressure Controller, w/Mini Slave, Lt Driver	1
			Activation, Water Level G - pb) parking brake is applied	
381	0760619		Water Level Gauge, WIn PSTANK2, LED 1-Light, 4-Level, PMFD	2
			Qty, - 02	
			Activation, Water Level G - Pump in gear or parking brake applied	
			Location, Water Level Gauge, Multi-Select - Cab, Behind Left Cab Door	
			and Cab, Behind Right Cab Door	
			Color, Trim - Chrome Trim	
382	0062992		Gauge, Foam Level, (1) Tank, Class 1, GAAAR 5lt	1
383	0682503		Light Shield/Step 8", LED, P25 LED Stp Lt	1
384	0606694		Air Horns, (2) Hadley, 6" Round, eTone, In Bumper	1
385	0604594	SP	Location, Air Horn(s), Bumper, Special Location	1
			Location - TBD	
386	0757092		Control, Air Horn, Multi Select	1
387	0757077		Control, Air Horn, Lanyard, LS	1
			Lanyard - Link Chain, Vinyl Tubing	
388	0533071		Siren, WIn 295SLSC1, 100 or 200 Watt, w/Plug-in/Detachable Microphone Cord	1
389	0510206		Location, Elect Siren, Recessed Overhead In Console	1
			Location, Elec Siren - Overhead, DS Inside Sw Pnl	
390	0748306		Control, Elec Siren, Multi Select	1
391	0748292		Control, Elec Siren, Push Button Sw, RS	1
392	0748293		Control, Elec Siren, Ft Sw, RS	1
393	0601304		Speaker, (2) WIn, SA315P, w/Pierce Polished Stainless Steel Grille, 100 watt	1
			Connection, Speaker - siren head	
394	0605153	SP	Location, Recessed in the Front Bumper, Driver and Passenger Side Corners	1
395	0746353		Not Required, Warning Lights Intensity	1
396	0637518		Lightbar, WIn, Justice, LED, 8-R, 2-W, LED, Clear Lens	1
397	0552524		Lights, Front Zone, WIn M6# LED, Split, Clear Lens, In Common Bzl	1
			Color, Lt DS Frnt Out Spl - a) Red and White	
			Color, Lt PS Frnt Out Spl - a) Red and White	
398	0653937		Flasher, Headlight Alternating	1
			Headlt flash deactivation - a)w/high beam	
399	0567481		Lights, Side Zone Lower, WIn M6 LED, Front Split Color, Clear Lens, 3pr	1
			Location, Lights Mid - lower cab corner	
			Location, Lights Rear - over rear wheels	
			Location, Lights Front Side - b)each side bumper	

Line	Option	Type	Option Description	Qty
399			Color, Lt Side Middle - Red	
			Color, Lt Side Rear - Red	
			Color, Lt Side Frnt Split - Red and Amber	
400	0564655		Lights, Rear Zn Lwr, WIn M6*C LED, Clear Lens, For Tail Lt Housing	1
			Color, Lt DS Rear - r) DS Rear Lt Red	
			Color, Lt PS Rear - r) PS Rear Lt Red	
401	0088745		Light, Rear Zone Up, WIn L31HRFN LED Beacon, Red LED	1
			Color, Dome, Rear Warning - j) both domes clear	
402	0006551		Not Required, Lights, Rear Upper Zone Blocking	1
403	0016621		Mtg, Rear Warn Lts, LS Compt Top, RS S/S low mount	1
404	0791528		Light, Traffic Directing, WIn TAL65, 36.00" Long, TACTL5	1
			Activation, Traffic Dir L - Aux Flash with Emergency Master	
405	0529858		Location, Traf Dir Lt, Recessed Within Trdplt Step	1
406	0530281		Location, Traf Dir Lt Controller, Center Console in Sw Pnl	1
407	0006646		Electrical System, 120/240VAC, General Design	1
408	0519098		Generator, Harrison C-Gen 6.0 kW Hydraulic, Hotshift PTO, PMFD	1
			Generator Interlocks - No Interlocks	
409	0594482	SP	Location, Hydraulic Generator, Hosebed	1
			Location, Generator - see drawing	
410	0016752		Starting Sw, Truck Engine Powered Gen, Cab Sw Pnl	1
411	0016757		Not Required, Remote Start, Generator	1
412	0016740		Not Required, Fuel System	1
413	0016767		Not Required, Oil Drain Extension, Generator	1
414	0036738		Circuit Breaker Panel, Included With PTO Generator	1
			Location, Circuit Breaker Panel - LS3, Back Wall High Left	
415	0679592	SP	Cover, Gen, Above Pump, Full Width, Knockouts	1
416	0016771		Not Required, Routing Exhaust, Generator	1
417	0006825		Reel, Elect Cable, Hannay, 1600, (3) Wire	2
			Qty, Cord Reels - 2	
			Reel Guide - b) Captive roller	
			Finish, Reel - Painted Gray	
			Location, Electric Cord Reel - Above Pump With Generator, 1 Reel	
418	0016828		Cord, Electric, 10/3 Black, 3 Wire	1
			Lengths of Elect Cord - 1	
			Feet of Black Cord - d)200	
			Connection, Cord - Direct connection	
419	0006828		Cord, Electric, 10/3 Yellow, 3 Wire	1
			Lengths of Elect Cord - 1	
			Feet of Yellow Cord - e)200	
			Connection, Cord - Direct connection	
420	0788933		Box, Junc, Akron, 3Wire, 2-15/20A 120V Dup SB, 2-20A 120V TL	2
			Qty, - 02	
			Connection, Electric Plug / Inlet (Male) - Direct Connection	
421	0781579		Receptacle, 15/20A 120V 3-Pr 3-Wr, NEMA 5-20R SB Dup, 1st, Interior Cab	1
			Qty, - 01	
			Location 1 - med cabinet, centered, up high, rear wall	
			AC Power Source - Shoreline	
			Cover, Receptacle - Interior SS Wall Plate(s)	
422	0779722		Receptacle, 15/20A 120V 3-Pr 3-Wr, NEMA 5-20R SB Dup, 1st, Interior Body	1
			Qty, - 01	
			Location 1 - TBD	
			AC Power Source - Shoreline	
			Cover, Receptacle - Interior, Flip Up Duplex Cover(s)	
423	0783678		Receptacle, 15/20A 120V 3-Pr 3-Wr, NEMA 5-20R SB Dup, 1st	3
			Location, Receptacles - DS over rear wheel panel, PS over rear wheel panel, rear body	
			Qty, - 03	
			AC Power Source - Generator	
			Cover, Receptacle - Exterior Flip Up Duplex Cover(s)	
424	0519934		Not Required, Brand, Hydraulic Tool System	1
425	0649753		Not Required, PTO Driven Hydraulic Tool System	1
426	0602516		NFPA Required Loose Equipment, Pumper, NFPA 2016, Provided by Fire Department	1
427	0519913		Not Required, Soft Suction Hose	1

Line	Option	Type	Option Description	Qty
428	0027023		No Strainer Required	1
429	0017066		Extinguisher, 20lb CO2	1
			Qty, Extinguishers - 1	
430	0533246		Extinguisher, 20 lb Dry Chemical	1
			Qty, Extinguishers - 1	
431	0533277		Extinguisher, 2.5 Gal. Pressurized Water	1
			Qty, Extinguishers - 1	
432	0602679		Axe, Flathead, Pumper NFPA 2016 Classification, Provided by Fire Department	1
433	0602667		Axe, Pickhead, Pumper NFPA 2016 Classification, Provided by Fire Department	1
434	0607712		Paint Process / Environmental Requirements, PMFD	1
435	0601367		Paint, Single Color, Saber PMFD	1
			Paint Color, Saber, PMFD - #90 Red	
436	0646897		Paint Chassis Frame Assy, E-Coat, Standard	1
			Paint Color, Frame Assembly, Predefined - Standard Black	
437	0693798		Paint, Front Wheels	1
			Paint, Wheels - Red #90	
438	0693793		Paint, Rear Wheels, Single Axle	1
			Paint, Wheels - Red #90	
439	0733739		Paint, Axle Hubs	1
			Paint, Axle Hub - Black #101	
440	0736826	SP	Coating, Durabak, Top/Bottom Flange, Front Bumper **	1
			Color, Durabak Coating - Textured Black	
441	0581434		Transit Coating, Carwell, Corrosion Protection, Including Underside	1
442	0007230		Compartment, Painted, Spatter Gray	1
443	0544124		Reflective Band, 1"-4"-1"	1
			Color, Reflect Band - A - i) gold	
			Color, Reflect Band - B - l) white	
			Color, Reflect Band - C - ze) gold	
444	0007356		Reflective across Cab Face	1
445	0536954		Stripe, Chevron, Rear, Diamond Grade, Pumper	1
			Color, Rear Chevron DG - fluorescent yellow green	
446	0545179		Stripe, Diamond Grade, Chevron, Front Bumper	1
			Size, Chevron Striping - 06	
			Color, Chevron DG - Yellow Green, Fluorescent	
			Color, Chevron DG - B - Red	
447	0065687		Stripe, Reflective, Cab Doors Interior	1
			Color, Reflective - a) white	
448	0033179		Lettering Specifications, Reflective	1
449	0686160		Lettering, Reflective, 3.00", (21-40)	1
			Outline, Lettering - Outline and Shade	
450	0685979		Lettering, Reflective, 16.00", Each	6
			Qty, Lettering - 06	
			Outline, Lettering - Outline	
451	0686010		Lettering, Reflective, 6.00", (21-40)	1
			Outline, Lettering - Outline and Shade	
452	0537144		Emblem, Reflective, Per Dept. Patch, Each, PMFD	2
			Qty, - 02	
			Location, Emblem - rear cab doors	
452	0000000	STF	TFT DS1040P 1" Nozzle with Pistol Grip and Bail Control FRFA	1
452	0000000	STF	Contingency Fund, For Equipment Mounting and Changes	1
452	0000000	STF	Inspection trip #2 - when - number of people	3
			Location - Main manufacturing facility	
			Qty, - 03	
452	0000000	STF	Inspection trip #1 - when - number of people	3
			Location - main manufacturing facility	
			Qty, - 03	
453	0772003		Manual, Fire Apparatus Parts, USB Flash Drive, Custom	1
			Qty, - 01	
454	0772037		Manual, Chassis Service, USB Flash Drive, Custom	1
			Qty, - 01	
455	0773381		Manual, Chassis Operation, (1) USB Flash Drive, Custom	1
456	0030008		Warranty, Basic, 1 Year, Apparatus, WA0008	1
457	0696698		Warranty, Engine, Cummins, 5 Year, WA0181	1

Line	Option	Type	Option Description	Qty
458	0684952		Warranty, Steering Gear, TRW Ross TAS, 1 Year WA0202	1
459	0596017		Warranty, Frame, 50 Year, Custom Chassis, WA0013	1
460	0663011		Warranty, Axle, 1 Year, Marmon Harrington, General Service	1
461	0610485		Warranty, Axle, Eaton/Dana, 5 Year/100,000 Mile, Parts and Labor	1
462	0652758		Warranty, ABS Brake System, 3 Year, Meritor Wabco, WA0232	1
463	0019914		Warranty, Structure, 10 Year, Custom Cab, WA0012	1
464	0595813		Warranty, Paint, 10 Year, Cab, Pro-Rate, WA0055	1
465	0695416		Warranty, Pierce Camera System, WA0188	1
466	0647720		Warranty, Pierce LED Strip Lights, WA0203	1
467	0046369		Warranty, 5-year EVS Transmission, Standard Custom, WA0187	1
468	0685945		Warranty, Transmission Cooler, WA0216	1
469	0688798		Warranty, Water Tank, Lifetime, UPF, Poly Tank, WA0195	1
470	0596025		Warranty, Structure, 10 Year, Body, WA0009	1
471	0693127		Warranty, Gortite, Roll-up Door, 6 Year, WA0190	1
472	0734463		Warranty, Pump, Waterous, 7 Year Parts, WA0382	1
473	0648675		Warranty, 10 Year S/S Pumbing, WA0035	1
474	0657990		Warranty, Foam System, Husky 3, WA0231	1
475	0725636		Warranty, Harrison Generator, 2 Year	1
476	0595820		Warranty, Paint, 10 Year, Body, Pro-Rate, WA0057	1
477	0595412		Warranty, Graphics Lamination, 1 Year, Apparatus, WA0168	1
478	0683627		Certification, Vehicle Stability, CD0156	1
479	0807826		Certification, Engine Installation, Saber FR/Enf, Cummins L9, 2024	1
480	0686786		Certification, Power Steering, CD0098	1
481	0892691		Certification, Cab Integrity, Saber FR/Enforcer, CD0189	1
482	0631973		Certification, Cab Door Durability, Saber FR/Enforcer, CD0137	1
483	0631978		Certification, Windshield Wiper Durability, Saber FR/Enforcer, CD0132	1
484	0556828		Certification, Electric Window, Not Available	1
485	0631977		Certification, Seat Belt Anchors and Mounting, Saber FR/Enforcer, CD0134	1
486	0735949		Certification, Cab HVAC System Performance, SFR/Enf, CD0165/CD0167/CD0174/CD0175	1
487	0545073		Amp Draw Report, NFPA Current Edition	1
488	0002758		Amp Draw, NFPA/ULC Radio Allowance	1
489	0799248		Appleton/Florida BTO	1
490	0000017		FLORIDA DIVISION BODY	1
491	0000012		PIERCE CHASSIS	1
492	0004713		ENGINE, OTHER	1
493	0046395		EVS 3000 Series TRANSMISSION	1
494	0020011		WATEROUS PUMP	1
495	0020009		POLY TANK	1
496	0028048		FOAM SYSTEM	1
497	0020006		SIDE CONTROL	1
498	0020007		AKRON VALVES	1
499	0020015		ABS SYSTEM	1
500	0658751		PUMPER BASE	1



Electrical Analysis

11/10/2022

Bid #: 1177 **Job #:**
Desc: Nederland Saber 4x4 Engine 750 Gallon LHB **Sales Rep:** Byrne, Jason
Customer: Nederland Fire Protection District **Organization:** Front Range Fire Apparatus, Ltd
Option: Electrical Power/Signal Protection & Control, Saber FR **Type:** Hard Wired

Option	Description	Type*	Minimum Load	Intermittent Load	Total Connected
0001244	High Idle w/Electronic Engine, Custom		0.00	1.20	0.00
0002526	Light, Engine Compt, All Custom Chassis		0.00	1.60	0.00
0005748	Heater, Hot Water, 33,000 BTU		0.00	0.00	6.72
0005945	Light, Pump Compt		0.00	1.80	0.00
0006825	Reel, Elect Cable, Hannay, 1600, (3) Wire		0.00	72.00	0.00
0009429	Electric Power Only, Portable Winch		0.00	1.00	0.00
0012122	Fans, Window Defrost, One (1) Fan on Each Side		0.00	0.00	5.00
0062992	Gauge, Foam Level, (1) Tank, Class 1, GAAAR 5lt		0.00	0.00	1.00
0072176	Primer, Trident, Air Prime, Air operated, w/(2) Additional Priming		0.00	0.01	0.00
0079166	Batteries, (4) Exide Grp 31, 950 CCA ea, Threaded Stud		0.00	3.00	0.00
0543751	Light, Do Not Move Apparatus		0.00	0.80	0.00
0549333	Indicators, Engine, Included with Pressure Controller		0.00	0.35	0.00
0553643	Control, Air Horn at Pmp Pnl, Red Switch		0.00	0.16	0.00
0589905	Alarm, Back-up Warning, PRECO 1040		0.00	0.50	0.00
0624939	Foam Sys, Husky 3, Single Agent, Multi Select Feature		0.00	55.00	0.00
0630142	Moisture Ejectors, Automatic, w/Heat, All Tanks, Enforcer/Saber		0.00	0.00	4.70
0632611	ESC/ABS/ATC Wabco Brake System, Single Rear Axle, 4x4 ABS,		0.00	6.00	0.00
0636439	Wiring, Spare, 37.5 A 12V DC, Cust Install Radio, 30A Bat Dir,		0.00	0.00	75.00
0644201	Cab Lift, Elec/Hyd, Saber FR/Enforcer		0.00	180.00	0.00
0653937	Flasher, Headlight Alternating		0.00	0.00	0.08
0663471	Rack, Zico Quic-Lift, Side Sheet Mount		0.00	28.00	0.00
0681751	Handlight, Streamlight, E- Flood LiteBox, 45805 LED, 12v		0.00	1.00	0.00
0687994	Engine Brake, Jacobs Compression Brake, Cummins Engine		0.00	0.42	0.00
0735095	Intercom, David Clark, 4-Pos, 2-Dual Radio, (D, O, RPTT), 2obC,		0.00	0.00	0.50
0741057	Heater, Gauge, IC, Including Master Gauges, Test Port and Press		0.00	0.00	2.25
0755334	Handlts, (3) Streamlight, Vulcan 180, 44315, 12v, Orange		0.00	0.75	0.00
0760619	Water Level Gauge, WIn PSTANK2, LED 1-Light, 4-Level, PMFD		0.00	0.00	1.60
0768376	Lights, Walk Surf, FRP Flood, LED, Qty, Loc Fet		0.00	0.00	0.00
0773109	Lights, HiViz FT-B-46-*-* LED, 3rd		0.00	0.00	15.00
0773358	Lights, HiViz FT-B-46-*-* LED, 2nd		0.00	0.00	15.00
0773362	Lights, HiViz FT-B-46-*-* LED, 1st		0.00	0.00	15.00
0797189	Wiring, Spare, 4.8 A 12V DC, USB Termination Blue Sea 1045 1st		0.00	0.00	5.00
0802935	Light, Directional, WIn M62T* LED, Cmn Bzl, Above Headlights,		0.00	1.50	0.00
0806466	Lights, Backup, WIn M62BU, LED, For Tail Lt Housing		0.00	3.20	0.00
0808066	Camera, Pierce, 7" HD, R, RS, LS Cameras, AHD		0.00	1.20	0.00
0887571	Winch, Superwinch, 18,000 lb. Fixed, Front, Tiger Shark,		0.00	500.00	0.00
0887784	Reel, Booster, Steel - Over Pump, Left Side, 2/3 H.P. Motor,		0.00	36.00	0.00
0889852	Lights, HiViz FT-B-46-*-* , 46", Brkt Fet 2nd		0.00	0.00	14.40
0889855	Lights, HiViz FT-B-46-*-* , 46", Brkt Fet 1st		0.00	0.00	14.40
0579886	Wiring, Spare, 50 A 12V DC, 6 Circuit Fuse Block, Blue Sea 5025	Load Managed	0.00	0.00	150.00
0741237	HVAC, Saber FR, CARE	Load Managed	0.00	0.00	100.00
0790483	Light, Visor, HiViz, FT-MB-33-*-* , 42.44" long	Load Managed	0.00	0.00	13.70
0002758	Amp Draw, NFPA/ULC Radio Allowance	NFPA	5.00	0.00	0.00
0013671	Compt, Rear, Rollup, 30.75" FF, 25.88" D	NFPA	0.90	0.00	0.90
0088745	Light, Rear Zone Up, WIn L31HRFN LED Beacon, Red LED	NFPA	3.20	4.80	0.00
0519098	Generator, Harrison C-Gen 6.0 kW Hydraulic, Hotshift PTO,	NFPA	19.30	0.00	0.00
0531188	LS 152" Rollup, Full Height Front & Rear, FDLER, Raised Rear 6"	NFPA	4.50	0.00	4.50

* UDMC = User Defined Mission Critical, LM = User Defined Load Managed, S = Electrical Amperage Supply



Electrical Analysis

11/10/2022

Bid #: 1177
Desc: Nederland Saber 4x4 Engine 750 Gallon LHB
Customer: Nederland Fire Protection District
Option: Electrical Power/Signal Protection & Control, Saber FR

Job #:
Sales Rep: Byrne, Jason
Organization: Front Range Fire Apparatus, Ltd
Type: Hard Wired

Option	Description	Type*	Minimum Load	Intermittent Load	Total Connected
0533071	Siren, WIn 295SLSC1, 100 or 200 Watt, w/Plug-in/Detachable	NFPA	0.80	7.20	0.00
0552524	Lights, Front Zone, WIn M6# LED, Split, Clear Lens, In Common	NFPA	1.80	2.70	0.00
0556337	Lights, Step, P25 LED at Rear Tailboard, 2lts Perm Lts	NFPA	0.50	0.00	0.00
0563675	Lights, Clearance/Marker/ID, Rear, Truck-Lite 33050R LED 7Lts	NFPA	0.35	0.00	0.00
0564655	Lights, Rear Zn Lwr, WIn M6*C LED, Clear Lens, For Tail Lt	NFPA	1.80	2.70	0.00
0567481	Lights, Side Zone Lower, WIn M6 LED, Front Split Color, Clear	NFPA	5.40	8.10	0.00
0586382	Gauges, Engine, Included With Pressure Controller	NFPA	0.30	0.00	0.00
0610240	Vehicle Data Recorder w/Seat Belt Monitor	NFPA	0.50	0.00	0.00
0618791	DEF Tank, 4.5 Gallon, DS Fill, Forward of Axle, Common Air	NFPA	0.60	11.40	0.00
0620054	Light, Directional/Marker, Intermediate, Weldon 9186-8580-29	NFPA	0.10	0.90	0.00
0625654	Cab, Saber FR, 6000	NFPA	6.80	10.20	0.00
0637518	Lightbar, WIn, Justice, LED, 8-R, 2-W, LED, Clear Lens	NFPA	6.00	1.00	1.50
0644176	Load Manager, Integrated In Electrical System, Saber FR/Enforcer	NFPA	0.56	0.56	0.00
0644187	Cab Instruments, Black Gauges, Black Bezels, Saber FR/Enforcer	NFPA	1.26	0.00	0.00
0644228	Air Dryer, Wabco System Saver 1200 IWT, Heated, 10" Frame,	NFPA	7.81	0.00	0.00
0645877	Lights, Hose Bed, Sides, Dual LED Light Strips	NFPA	2.52	0.00	0.00
0647647	Lights, Dome, FRP Dual LED 4 Lts	NFPA	0.80	0.80	0.00
0647802	Lights, Clearance/Marker/ID, Front, P25 LED 5 Lts, Saber	NFPA	0.35	0.00	0.00
0647899	Lights, Directional/Marker, Cab Front Side, Weldon 9186-8580-29	NFPA	0.80	0.00	0.00
0682503	Light Shield/Step 8", LED, P25 LED Stp Lt	NFPA	4.00	0.00	0.00
0721606	Controller, Pressure, Pierce LCD, Metric, Custom Chassis	NFPA	1.70	0.00	0.00
0739224	Indicator Light @ Pump Panel, Throttle Ready, Incl w/Pressure	NFPA	0.10	0.00	0.00
0739749	Gauge, Water Level, Pierce, In pressure Controller, w/Mini Slave,	NFPA	1.23	0.00	0.00
0745568	Indicator Light, Pump Panel, Ok To Pump, Green	NFPA	0.10	0.00	0.00
0769559	Lights, Perimeter Pump House, Amdor AY-LB-12HW012 LED 2lts	NFPA	0.36	0.00	0.00
0769560	Lights, Perimeter Body, Amdor AY-LB-12HW012 LED 2lts, Rear	NFPA	0.36	0.00	0.00
0769567	Lights, Perimeter, Amdor AY-LB-12HW012 12", Brkt	NFPA	1.08	0.00	0.00
0769569	Lights, Perimeter Cab, Amdor AY-LB-12HW012 LED 4Dr	NFPA	0.72	0.00	0.00
0785367	Cabinet, Forward Facing, Center, 38.50 W x 50 H x 18 D, Roll,	NFPA	0.50	0.50	0.00
0791528	Light, Traffic Directing, WIn TAL65, 36.00" Long, TACTL5	NFPA	0.60	1.20	0.00
0804514	Lights, Tail, WIn M62BTT* Red Stop/Tail & M62T* Amber Dir Arw	NFPA	0.83	2.49	0.00
0805875	Engine, Cummins L9, 450 hp, 1250 lb-ft, W/OBD, EPA 2024,	NFPA	1.00	0.00	0.00
0887559	Trans, Allison 6th Gen, 3000 EVS P, w/Prognostics,	NFPA	2.00	2.00	0.00
0887574	RS 152" Rollup, 3/4 Height Front Rear, (1) Lap Broom, FDLER,	NFPA	1.80	0.00	1.80
0888792	Headlights, Rect LED, 4X4, JW Spkr Evo 2, Heat, Saber	NFPA	5.46	7.82	0.00
0889577	Bracket, License Plate & Light, P25 LED, Stainless Brkt	NFPA	0.07	0.00	0.00
0892638	Lights, Cab & Crw Cab Acs Stps, P25, LED w/Bezel, 6lts	NFPA	1.00	0.00	0.00
0647729	Alternator, 320 amp, Delco Remy 40SI	S	0.00	0.00	0.00
Load Totals:			94.86	959.86	448.05

Note: Minimum Continuous Load is in "Blocking Right of Way" mode. (Reference current edition of NFPA 1901)
Note: Intermittent Load items are not factored in on any alternator load comparisons. These items are included on the report for reference only and should be looked at as amp draw exclusion items. (Reference current edition of NFPA 1901)
Note: Total Connected Load "Demand" represents Total Connected Load minus any Load Managed items

Alternator Output at Idle: 187.00

Alternator Output at Governed Speed: 285.00

* UDMC = User Defined Mission Critical, LM = User Defined Load Managed, S = Electrical Amperage Supply



Electrical Analysis

11/10/2022

Bid #: 1177
Desc: Nederland Saber 4x4 Engine 750 Gallon LHB
Customer: Nederland Fire Protection District
Option: Electrical Power/Signal Protection & Control, Saber FR

Job #:
Sales Rep: Byrne, Jason
Organization: Front Range Fire Apparatus, Ltd
Type: Hard Wired

Minimum Continuous Load	
Supply:	187.00
Demand:	94.86
Variance:	92.14

Total Connected Load	
Supply:	285.00
Demand:	279.21
Variance:	5.79

* UDMC = User Defined Mission Critical, LM = User Defined Load Managed, S = Electrical Amperage Supply



Turning Performance Analysis

11/10/2022

Bid Number: 1177

Department: Nederland Fire Protection District

Chassis: Saber FR Chassis 4x4

Body: Pumper, Medium, Aluminum, 2nd Gen, Saber

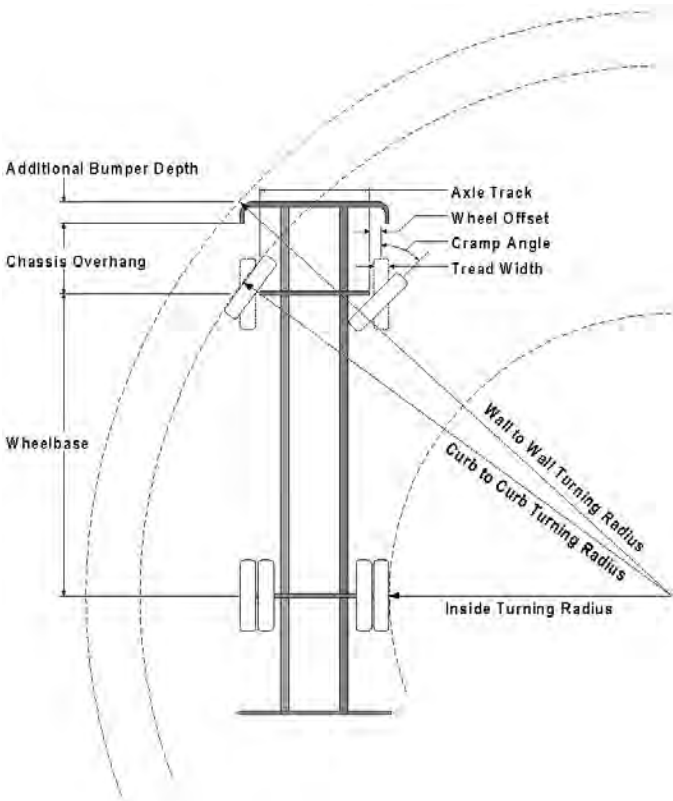

Parameters:

*Inside Cramp Angle:	40°
Axle Track:	85.86 in.
Wheel Offset:	5.25 in.
Tread Width:	12.5 in.
Chassis Overhang:	65.95 in.
Additional Bumper Depth:	0.00 in.
Front Overhang:	65.95 in.
Wheelbase:	177.5 in.

Calculated Turning Radii:

Inside Turn:	16 ft. 8 in.
Curb to curb:	29 ft. 10 in.
Wall to wall:	32 ft. 9 in.

Category	Option	Description
Wheels, Front	0789277	Wheels, Front, Accuride, 22.50" x 9.00", Steel, Hub Pilot, 315/80R, 5.25" Inset
Axle, Front, Custom	0737375	Axle, Front, Marmon Herrington MT-22 19,450 lb, (FWD) Saber FR/Enforcer
Tires, Front	0664491	Tires, Front, Michelin, XZU S2, 315/80R22.50, 20 ply
Bumpers	0776057	Bumper, 16" Extended .38" Formed Steel, 10.38"H, Painted, Saber FR/Enforcer

Notes:

*Actual Inside cramp angle may be less than shown.

Curb to Curb turning radius calculated for 9.00 inch curb.

Definitions:

Inside CrampAngle	Maximum turning angle of the front inside fire.
Axle Track	King-pin to King-pin distance of front axle.
Wheel Offset	Offset from the center line of the wheel to the King-pin.
Tread Width	Width of the tire tread.
Chassis Overhang	Distance of the center line of the front axle to the front edge of the cab. This does not include the bumper depth.
Additional Bumper Wheel	Depth that the bumper assembly adds to the front overhang.
Wheelbase	Distance between the center lines of the vehicles front and rear axles.
Inside Turning Radius	Radius of the smallest circle around which the vehicle can turn.
Curb to Curb Turning Radius	Radius of the smallest circle around which the vehicle's tires can turn. This measures assumes a curb height of 9 inches.
Wall to Wall Turning Radius	Radius of the smallest circle around which the vehicle's tires can turn. This measures takes into account any front overhang due to chassis , bumper extensions and or aerial devices.

Pumper/Tanker - Customer Summary
 Weight Distribution Worksheet 4.1



© 2009 by Pierce Manufacturing Inc., All Rights Reserved

CUSTOMER NAME: Nederland Fire Protection District BID / JOB #: 1177 VEHICLE TYPE: Saber FR Pumper 4x4 AL BY: Cole Knitt DATE: 4/7/2022		SUMMARY		
Manufacturer: Pierce Saber FR Chassis: Saber FR 4x2, 4x4, 60" Cab Engine/Transmission: L9 '21 / 3000 Body Type: Pumper, 152" Medium Extended Body Brand: Pierce Body Side Structure: High / ¾ High Body Construction: Aluminum Body Doors: Roll-up Front Axle Rating: 19,450 lb. 4x4 Rear Axle Rating: 24,000 lb.		Wheelbase =		177.5
		<i>Estimated Weights</i>	<i>FRONT</i>	<i>REAR</i>
		LOADED	18195	21919
		EMPTY	15848	11702
		TOTAL GVW=		40114
WHEELBASE CALCULATION		ESTIMATED AXLE LOADS		
Front Axle to Back of Cab	60	Front	Rear	
Cab - Pump Gap	2	Estimated	18195	21919
Walkthrough or Cab Module	0	Rated	19450	24000
Engineer Compartment	0	Ratio	45.4%	54.6%
Speedlays	0	Total GVW =	40114	
Pump House	48	ESTIMATED EMPTY WEIGHT		
Pump - Body Gap	1.5		15848	11702
Body to Rear Axle Length	66			
Wheelbase =	177.5			
		<i>Estimated Axle Loads are loaded in-service weights, including crew, hose, NFPA equipment allowance, water, foam, fuel and optional equipment such as generators.</i>		
		<i>Estimated Empty Weight represents an empty truck without crew, hose, NFPA equipment allowance, ladders, foam or water, but includes fuel and optional equipment such as generators.</i>		



Application Report Bundle

**449-A263833-1** (Iteration 1) *Preliminary*[US Units](#) | SI Units**APPLICATION PROFILE**

Date	April 8, 2022 09:12:24
Scaan Number	
Application	449-A263833-1
Application Name	1177 Nederland
Owner	Cole Knitt @ Pierce Manufacturing
SCAAN Analysis Type	Standard Vehicle Run
Optional Analysis Type	
Classification	Standard
Review Status	Not Submitted

Input Summary ▲**MISSION** ▲

End User	Nederland Fire Protection District (North America, Western)
Selected Vocation	Fire Service — Pumper - with Split Shaft PTO — Straight Truck (20-20-10)

PLATFORM ▲

Vehicle Manufacturer	Pierce Manufacturing (North America)
Vehicle Model	152" Pumper AL 4x4
Vehicle Configuration	Saber Fr

Area and Weight

Frontal Area	80.0 ft ²
Height / Width	10.00 ft / 8.00 ft
Standard Wind Resistance Coefficient	0.800 (no Deflector)
User Defined Wind Resistance Coefficient	0.800 (no Deflector)
Gross Vehicle Weight	40114 lb (no Trailer)
Weight On Drive Wheels	21919 lb (54.64%)

Tires

Number Of Tires	6 (Standard Radial)
Selected Tire	Goodyear G622 RSD (12R22.5, 482) (1-L003936-TI)
Tire Revolutions	482 revs/mi
Tire Rolling Radius	20.91 in
Standard Surface	Smooth Concrete (SC Factor = 1.00)
Selected Surface	Smooth Concrete (SC Factor = 1.00)
Standard On-Road Traction Limit Coefficient	0.700
Standard Off-Road Traction Limit Coefficient	0.000
User Defined On-Road Traction Limit Coefficient	0.700
User Defined Off-Road Traction Limit Coefficient	0.000
Tire/Wheel Inertia (estimated)	70.6575 lb-ft-sec²

ENGINE

Number of Power Packs	1
Engine	Cummins L9 (Diesel) -- 450hp / 1250lbft / 2200rpm -- (EPA21) (2-L008627-E, Rev B)
Certifications	USA 2021
Displacement	540.0 in³
Peak Torque	1250.0 lb-ft
Peak Torque Speed	1300 rpm
Peak Power	450.0 hp
Peak Power Speed	2100 rpm
Governed Power	419.9 hp
Governed Speed	2230 rpm
Number Of Curves	1
Engine Curve Reference	FR96230
Cruise Velocity @ Speed	60.0 mph @ 1500 rpm
Engine Retarder	
Engine Inertia (estimated)	1.5744 lb-ft-sec²

ENGINE CURVE - STANDARD LOSSES - COMBINED LOW & HIGH CURVES (AC ON WHERE APPLICABLE)

Speed (rpm)	Gross Power (hp)	Gross Torque (lb-ft)	Net Power Fan On (hp)	Net Torque Fan On (lb-ft)	Net Power Fan Off (hp)	Net Torque Fan Off (lb-ft)	Point Identification
700	89.3	670.0	71.3	534.9	72.8	546.2	
800	120.3	790.0	101.2	664.2	103.4	678.9	

900	149.9	875.0	129.4	755.1	132.6	773.7	
1000	224.7	1180.0	202.5	1063.6	206.9	1086.6	
1100	254.5	1215.0	230.4	1100.2	236.3	1128.0	
1200	285.6	1250.0	259.4	1135.3	267.0	1168.4	
1300	309.4	1250.0	280.7	1134.1	290.3	1173.0	Peak Torque
1400	333.2	1250.0	301.7	1131.8	313.7	1176.8	
1500	357.0	1250.0	322.3	1128.5	337.1	1180.2	
1600	380.8	1250.0	342.5	1124.4	360.4	1183.2	
1700	404.6	1250.0	362.3	1119.4	383.8	1185.8	
1849	439.9	1250.0	390.9	1110.7	418.5	1189.1	
1900	440.0	1216.3	388.4	1073.6	418.4	1156.5	
2000	440.0	1155.5	383.0	1005.7	417.9	1097.5	
2100	450.0	1125.4	387.0	967.8	427.5	1069.1	Peak Power
2200	435.0	1038.5	365.5	872.6	412.1	983.8	
2230	419.9	989.0	348.4	820.5	396.9	934.7	Governed
2300	254.9	582.0	178.3	407.2	231.5	528.7	
2400	0.0	0.0	-84.2	-184.3	-23.8	-52.1	No Load Governed

Peak Power point has been defined for the purposes of assessing Accessory Losses

PLOTS - ENGINE CURVE - STANDARD LOSSES - COMBINED LOW & HIGH CURVES (AC ON WHERE APPLICABLE) ▲

Standard Parameters Fan On

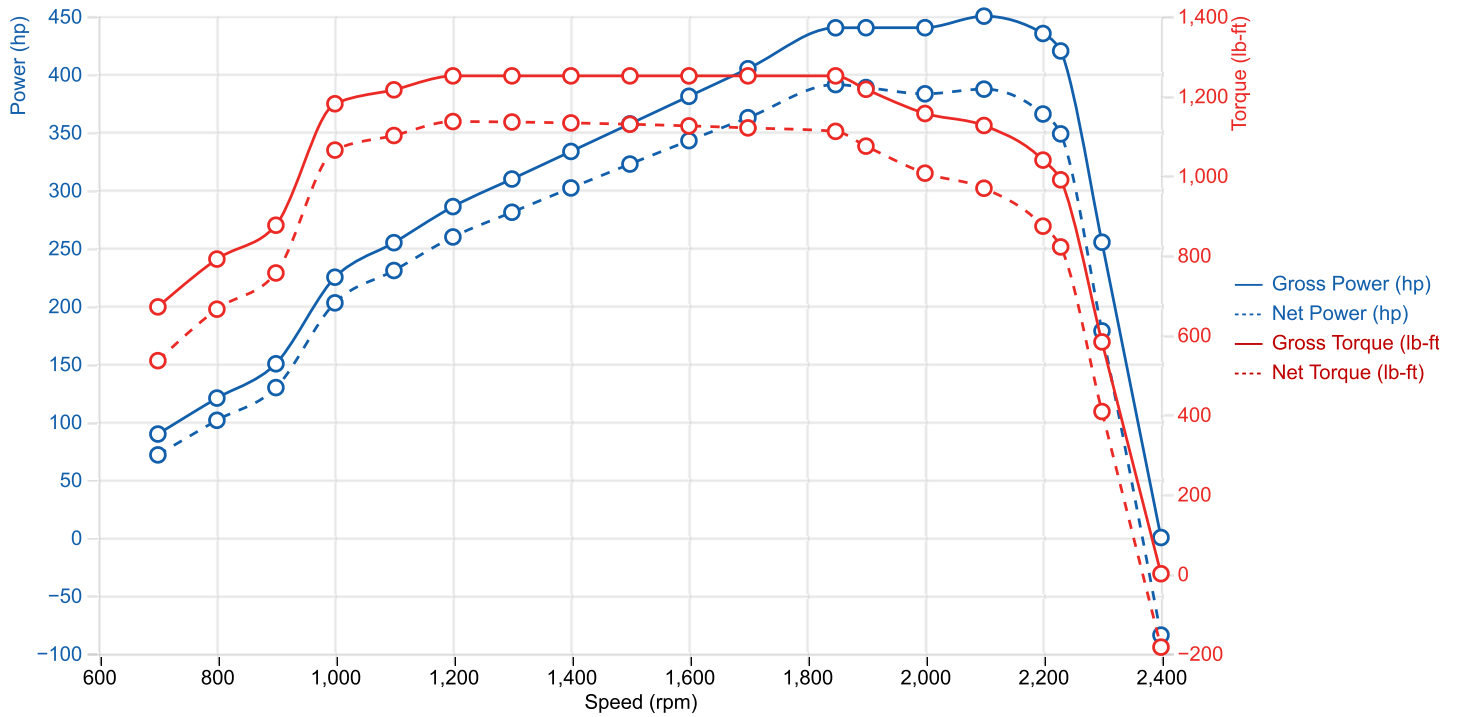

Standard Parameters Fan Off

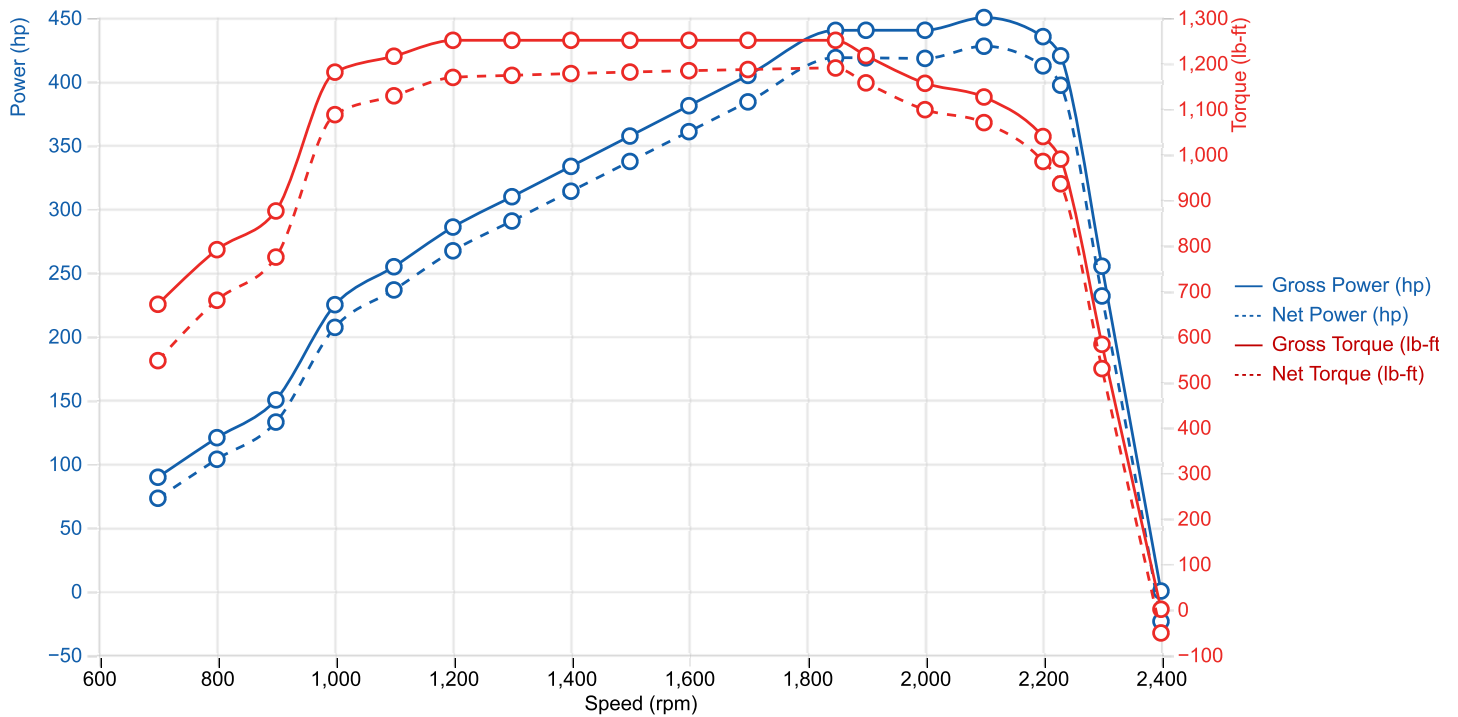

ENGINE CURVE - USER DEFINED LOSSES - COMBINED LOW & HIGH CURVES (AC ON WHERE APPLICABLE)

Speed (rpm)	Gross Power (hp)	Gross Torque (lb-ft)	Net Power Fan On (hp)	Net Torque Fan On (lb-ft)	Net Power Fan Off (hp)	Net Torque Fan Off (lb-ft)	Point Identification
700	89.3	670.0	71.3	534.9	72.8	546.2	

800	120.3	790.0	101.2	664.2	103.4	678.9	
900	149.9	875.0	129.4	755.1	132.6	773.7	
1000	224.7	1180.0	202.5	1063.6	206.9	1086.6	
1100	254.5	1215.0	230.4	1100.2	236.3	1128.0	
1200	285.6	1250.0	259.4	1135.3	267.0	1168.4	
1300	309.4	1250.0	280.7	1134.1	290.3	1173.0	Peak Torque
1400	333.2	1250.0	301.7	1131.8	313.7	1176.8	
1500	357.0	1250.0	322.3	1128.5	337.1	1180.2	
1600	380.8	1250.0	342.5	1124.4	360.4	1183.2	
1700	404.6	1250.0	362.3	1119.4	383.8	1185.8	
1849	439.9	1250.0	390.9	1110.7	418.5	1189.1	
1900	440.0	1216.3	388.4	1073.6	418.4	1156.5	
2000	440.0	1155.5	383.0	1005.7	417.9	1097.5	
2100	450.0	1125.4	387.0	967.8	427.5	1069.1	Peak Power
2200	435.0	1038.5	365.5	872.6	412.1	983.8	
2230	419.9	989.0	348.4	820.5	396.9	934.7	Governed
2300	254.9	582.0	178.3	407.2	231.5	528.7	
2400	0.0	0.0	-84.2	-184.3	-23.8	-52.1	No Load Governed

Peak Power point has been defined for the purposes of assessing Accessory Losses

PLOTS - ENGINE CURVE - USER DEFINED LOSSES - COMBINED LOW & HIGH CURVES (AC ON WHERE APPLICABLE) ▲

User Defined Parameters Fan On

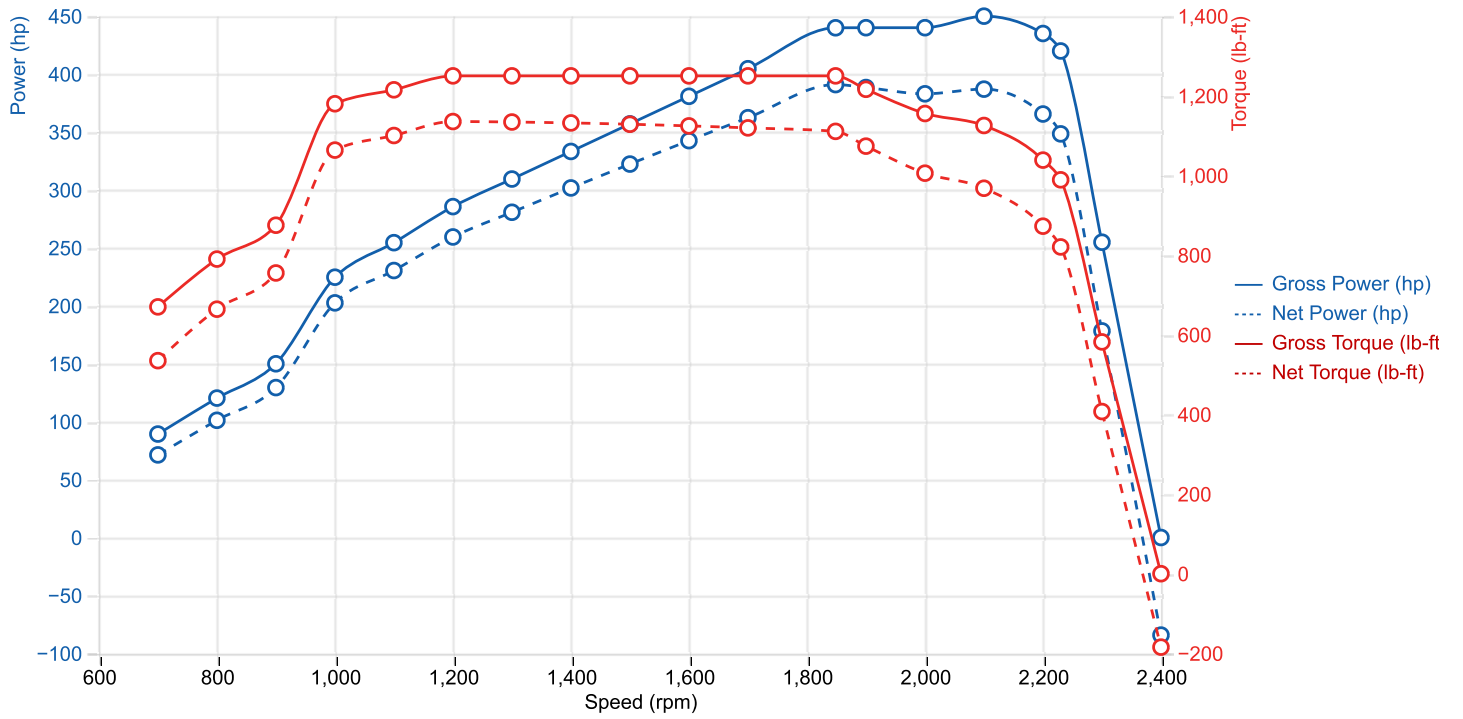

User Defined Parameters Fan Off

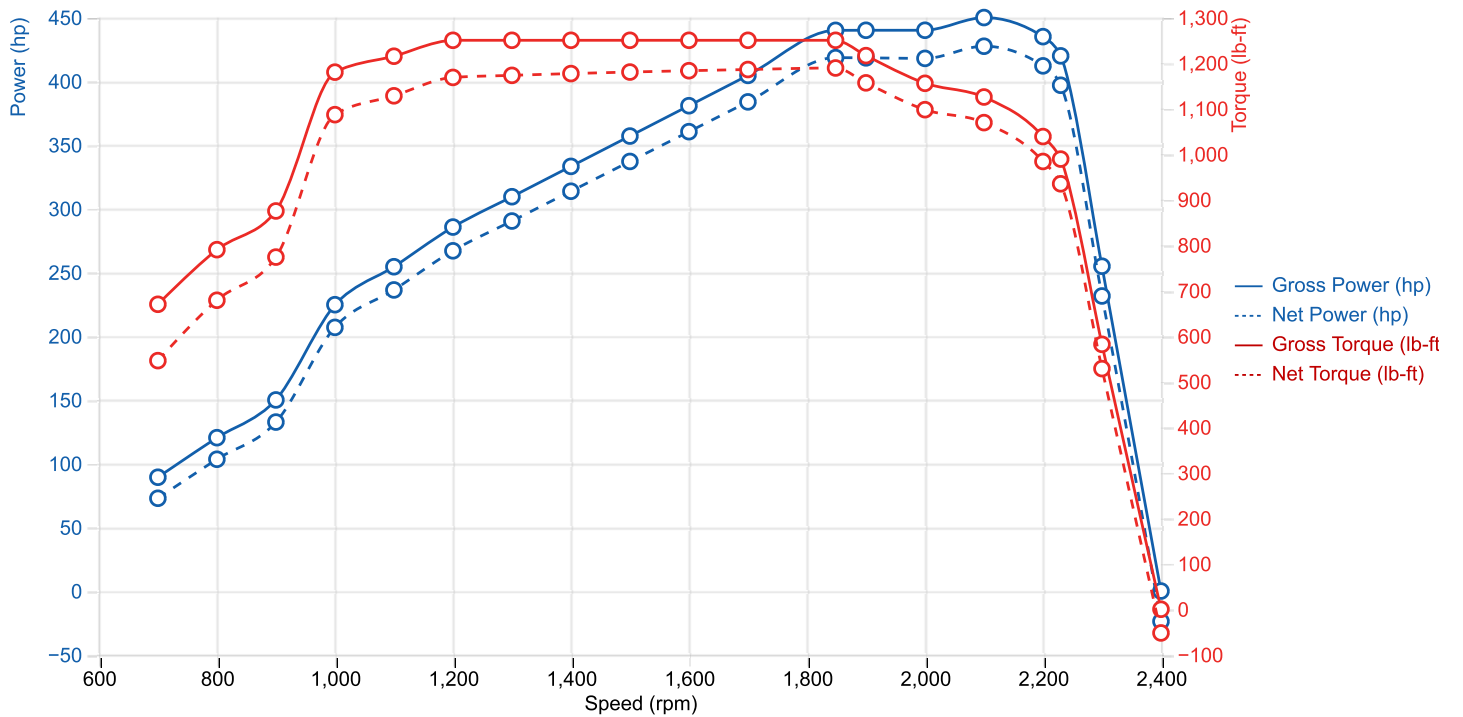

ACCESSORY LOSSES (POWER @ GOVERNED SPEED) ▲

Accessory	Standard Loss (hp)	User Defined Loss (hp)
Fan (Clutch Fan)	48.5	48.5
Alternator / Generator	13.5	13.5
Air Compressor	4.8	4.8
Steering Pump	4.8	4.8
Air Conditioning	0.0	0.0
Implement Drive	0.0	0.0

TRANSMISSION

Transmission Manufacturer	Allison Transmission
Transmission Family	3000 Series (1-L001243-TF, Rev AG)
Transmission	3000 EVS (1-L007339-T, Rev E)
Transmission Rating	3000 EVS Fire Truck, Emergency Vehicle - Diesel Allison 6th Generation Controls with SEM/LRTP (1-L018780-R, Rev A)
Torque Converter	TC421 (1-L001255-TC, Rev C) - Acceptable
Transmission Retarder	

CONTROLS

Controls Release	Production Calibration (PC) for 3000 Series (1-L001194-CR, Rev F)
Shift Schedule	Primary
DynActive	No
Speed Profile	Performance
Shift Speed & Strategy	2200 rpm S1 Performance
Equivalent DynActive Bias	0
Primary Mode: Gears	Low = 1, Start = 1, High = 5 (1-1-5)

DRIVELINE

Driveline Protection	No				
Component	Description	Ratio	Standard Efficiency (%)	User Defined Efficiency (%)	
Propshaft -- One Piece -- Two Joint (1-L003521-DL)	Single	1.000	98.60	98.60	
Axle -- On Hwy Single Red -- 4x4 (1-L003532-DL)	Single	4.330	95.00	95.00	
Overall Driveline Ratio	Description	Ratio	Standard Efficiency (%)	User Defined Efficiency (%)	N over V Ratio rpm/mpH
	Single	4.330	93.67	93.67	34.803

Ratings and Guidelines Check ▲**MISSION** ▲

End User	Nederland Fire Protection District (North America, Western)
Selected Vocation	Fire Service — Pumper - with Split Shaft PTO — Straight Truck (20-20-10)

PLATFORM ▲

Vehicle Manufacturer	Pierce Manufacturing (North America)
Vehicle Model	152" Pumper AL 4x4
Vehicle Configuration	Saber Fr
Engine Description	Cummins L9 (Diesel) -- 450hp / 1250lbft / 2200rpm -- (EPA21) (2-L008627-E, Rev B)
Transmission	3000 EVS (1-L007339-T, Rev E)
Transmission Rating	3000 EVS Fire Truck, Emergency Vehicle - Diesel Allison 6th Generation Controls with SEM/LRTP (1-L018780-R, Rev A)
Vehicle Parameters	Standard
Torque Converter	TC421 (1-L001255-TC, Rev C) - Acceptable
Transmission Retarder	
LRTP Status	LRTP Required

NOTE ▲

This SCAAN information is subject to the SCAAN Disclaimer set forth elsewhere.

CONVERTER RATING AND GUIDELINE CHECKS**SECTION SCORE - OK** ▲

Check	Check Name	Minimum or Maximum	Rating or Recommendation	Actual Value	Units	Overall Status
C01	Transmission / Converter Compatibility					OK: Acceptable
C02	Engine / Converter Compatibility					OK: Acceptable
C04	Engine Speed at Converter Stall			1728	rpm	Reference
C05	Minimum Engine Speed	Min	1300	1848	rpm	OK: Acceptable
C07	Turbine Torque at Converter Stall	Max	1700.0	1700.0	lb-ft	OK: Acceptable
C08	Converter Speed Ratio at Engine Governed Speed	Min	0.800	0.816		OK: Acceptable
C03	Converter Stall Torque Ratio			1.770		Reference

Notes

Check	Comments
C05	Net peak torque speed (1200 rpm) + allowable variation (100 rpm).

TRANSMISSION RATING AND GUIDELINE CHECKS	SECTION SCORE - OK
---	---------------------------

Check	Check Name	Minimum or Maximum	Rating or Recommendation	Actual Value	Units	Overall Status
T01 ▼?	Transmission / Vocation Compatibility					✓ OK: Acceptable
T02 ▼?	Transmission / Engine Compatibility					✓ OK: Acceptable
T20 ▼?	Engine is SEM/LRTP Capable					✓ OK: Acceptable
T17 ▼?	Transmission Permitted in End User/Chassis Mfg Locations					✓ OK: Acceptable
T15 ▼?	Transmission Input Power (Gross)	Max	450.0	450.0	hp	✓ OK: Acceptable
T14 ▼?	Transmission Input Torque (Gross)	Max	1250.0	1250.0	lb-ft	✓ OK: Acceptable
T03 ▼?	Transmission Input Speed		1900 / 2800	2230	rpm	✓ OK: Acceptable
T04 ▼?	Transmission Output Speed			2974	rpm	📌 Reference

Notes

Check	Comments
T04	Check made in Range 5L at 2230 Engine Governed Speed.

VEHICLE RATING AND GUIDELINE CHECKS - STANDARD

SECTION SCORE - OK ▲

Check	Check Name	Minimum or Maximum	Rating or Recommendation	Actual Value	Units	Overall Status
V11 ▼?	1st Range Converter Stall Gradeability	Min	30.00	35.68	%	✔ OK: Acceptable
V13 ▼?	1st Range 70% Converter Efficiency Gradeability			28.45	%	📖 Reference
V23 ▼?	1st Range 80% Converter Efficiency Gradeability			24.20	%	📖 Reference
V17 ▼?	Maximum Geared Vehicle Speed at Engine Governed Speed			85.5	mph	📖 Reference
V43 ▼?	Heat Generated in 1st Range 70% Converter Efficiency			5215.60	BTU/min	📖 Reference
V44 ▼?	Heat Generated in 1st Range 80% Converter Efficiency			3679.22	BTU/min	📖 Reference

Notes

Check	Comments
V17	Check is in 5L Lockup.
V43	At 1991 rpm Engine Speed.
V44	At 2091 rpm Engine Speed.

NATIONAL FIRE PROTECTION ASSOCIATION (NFPA) 1901 GUIDELINE CHECKS - STANDARD SECTION SCORE - REFERENCE ▲

Check	Check Name	Minimum or Maximum	Rating or Recommendation	Actual Value	Units
V26 ▼?	Minimum Vehicle Speed on 0.25% Grade (NFPA 1901)	Min	50.0	83.6	mph
V56 ▼?	Vehicle Speed on 6.0% Grade (NFPA 1901)	Min	20.0	43.3	mph
V27 ▼?	Gradeability at 50 mph (80 km/h) (NFPA 1901)	Min	0.25	4.77	%
V57 ▼?	Gradeability at 20 mph (32.2 km/h) (NFPA 1901)	Min	6.00	12.51	%
V28 ▼?	Maximum Acceleration Time, 0-35 mph (56.3 km/h), 0.0% Grade, 1st Range Start (NFPA 1901)	Max	25.0	11.5	sec

Notes

Check	Comments
V26	Check is in 5L
V56	Check is in 3L.
V28	Full Throttle & Vehicle Brakes Locked Start.

Vehicle Performance Summary

MISSION	
End User	Nederland Fire Protection District (North America, Western)
Selected Vocation	Fire Service — Pumper - with Split Shaft PTO — Straight Truck (20-20-10)
PLATFORM	
Vehicle Manufacturer	Pierce Manufacturing (North America)
Vehicle Model	152" Pumper AL 4x4
Vehicle Configuration	Saber Fr
Engine Description	Cummins L9 (Diesel) -- 450hp / 1250lbft / 2200rpm -- (EPA21) (2-L008627-E, Rev B)
Transmission	3000 EVS (1-L007339-T, Rev E)
Transmission Rating	3000 EVS Fire Truck, Emergency Vehicle - Diesel Allison 6th Generation Controls with SEM/LRTP (1-L018780-R, Rev A)
Vehicle Parameters	Standard
Torque Converter	TC421 (1-L001255-TC, Rev C) Acceptable
Transmission Retarder	
LRTP Status	LRTP Required
NOTE	

This SCAAN information is subject to the SCAAN Disclaimer set forth elsewhere.

FULL THROTTLE AUTOMATIC UPSHIFTS (GRADEABILITY) - STANDARD, FAN ON, AC OFF, AXLE RATIO = 4.330, AUX RATIO = 1.000

Engine Fan	On	Engine Power	Standard Power Curve
Air Conditioning	Off	Vehicle Parameters	Standard
Axle Ratio	4.330	Auxiliary Gearing Ratio	1.000

Gradeability	% Grade	Vehicle Speed (mph)	Gear Range	Match Point
Stall Gradeability	35.7		1C	Stall
Launch Gradeability	33.7		1C	
Low Speed Gradeability	24.2	10.9	1C	80 Percent
Maximum Speed on Grade	0.0	84.8	5L	Road Load
	0.3	83.6	5L	
	0.5	82.2	5L	
	1.0	78.6	5L	
	2.0	70.7	5L	
	3.0	61.1	4L	
	4.0	56.2	4L	
	5.0	45.6	4L	
	6.0	43.3	3L	
	7.0	40.1	3L	
	8.0	33.5	3L	
	9.0	32.7	2L	
	10.0	30.4	2L	

PLOTS - FULL THROTTLE AUTOMATIC UPSHIFTS (GRADEABILITY) - STANDARD, FAN ON, AC OFF, AXLE RATIO = 4.330, AUX RATIO = 1.000

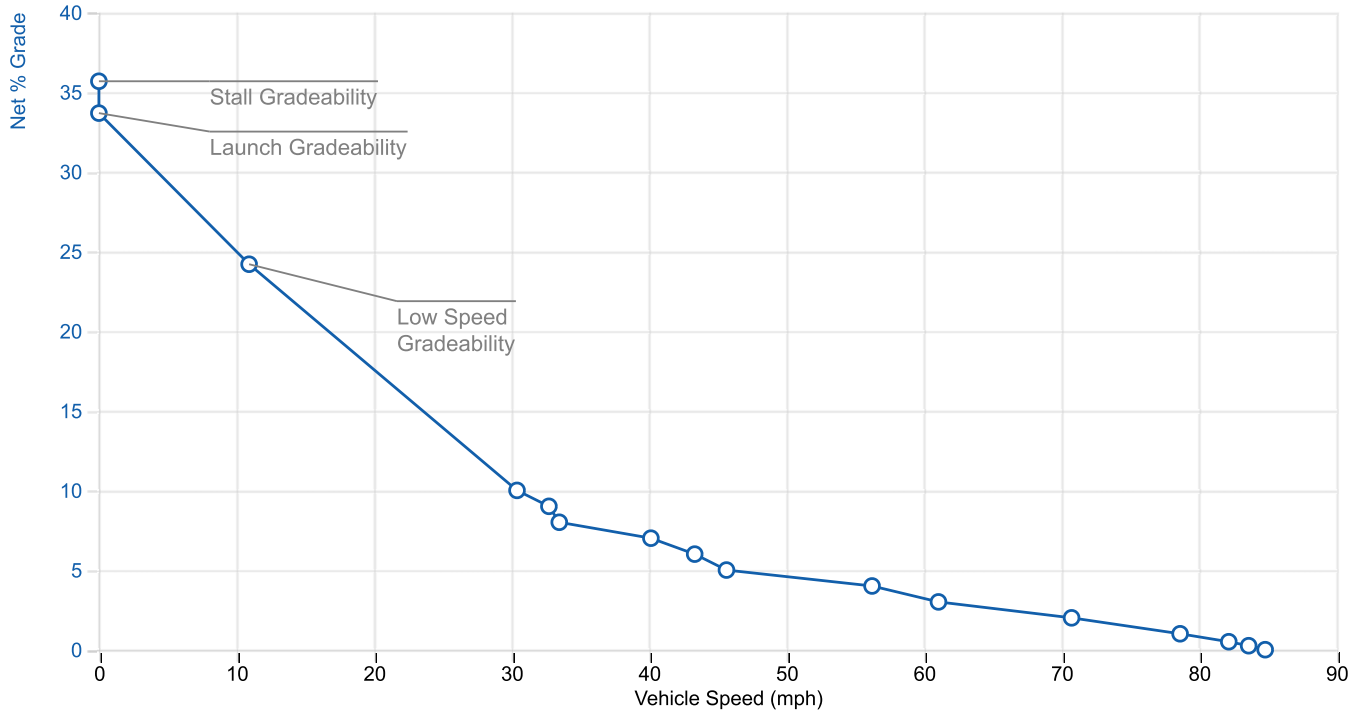

FULL THROTTLE AUTOMATIC UPSHIFTS (ACCELERATION) - STANDARD, FAN ON, AC OFF, AXLE RATIO = 4.330, AUX RATIO = 1.0▲

Engine Fan	On	Engine Power	Standard Power Curve
Air Conditioning	Off	Vehicle Parameters	Standard
Axle Ratio	4.330	Auxiliary Gearing Ratio	1.000

Speed	Time (seconds)	Distance (ft)
0 - 20 mph	4.6	80
0 - 30 mph	8.8	237
0 - 40 mph	14.6	538
0 - 50 mph	23.3	1117
0 - 60 mph	34.6	2033

PLOTS - FULL THROTTLE AUTOMATIC UPSHIFTS (ACCELERATION) - STANDARD, FAN ON, AC OFF, AXLE RATIO = 4.330, AUX RA▲

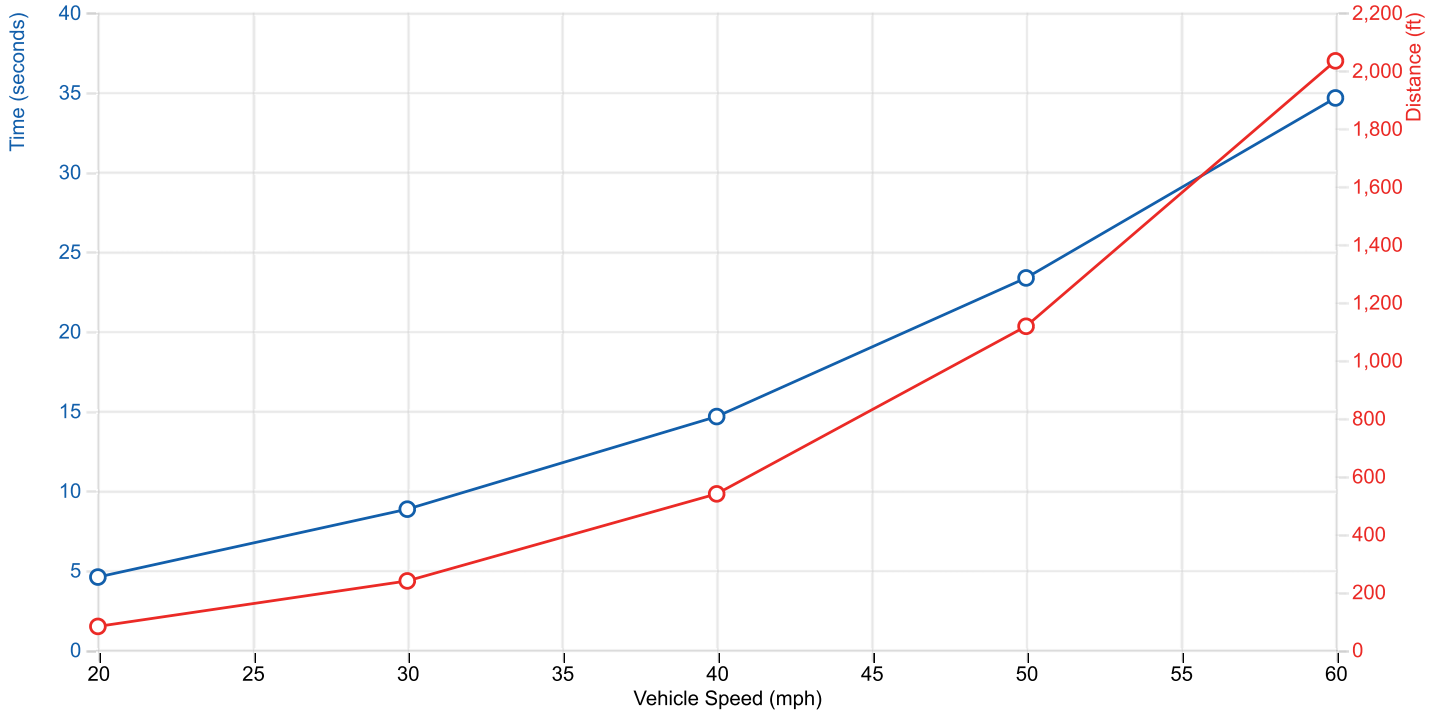

Vehicle Full Throttle Performance

MISSION

End User	Nederland Fire Protection District (North America, Western)
Selected Vocation	Fire Service — Pumper - with Split Shaft PTO — Straight Truck (20-20-10)

PLATFORM

Vehicle Manufacturer	Pierce Manufacturing (North America)
Vehicle Model	152" Pumper AL 4x4
Vehicle Configuration	Saber Fr
Engine Description	Cummins L9 (Diesel) -- 450hp / 1250lbft / 2200rpm -- (EPA21) (2-L008627-E, Rev B)
Transmission	3000 EVS (1-L007339-T, Rev E)
Transmission Rating	3000 EVS Fire Truck, Emergency Vehicle - Diesel Allison 6th Generation Controls with SEM/LRTP (1-L018780-R, Rev A)
Vehicle Parameters	Standard
Torque Converter	TC421 (1-L001255-TC, Rev C) Acceptable
Transmission Retarder	
LRTP Status	LRTP Required

NOTE

This SCAAN information is subject to the SCAAN Disclaimer set forth elsewhere.

Results indicate the vehicle operating conditions at steady state (acceleration = 0).

The **■** symbol indicates that Wheel Slip may occur.

FULL THROTTLE AUTOMATIC UPSHIFTS (1C-2C-2L-3L-4L-5L-6L) - STANDARD, FAN ON, AC OFF, AXLE RATIO = 4.330, AUX RATIO▲

Engine Fan	On	Air Conditioning	Off
Engine Power	Standard Power Curve	Vehicle Parameters	Standard
Axle Ratio	4.33	Auxiliary Gearing Ratio	1

Gear Range	Vehicle Speed (mph)	Engine Speed (rpm)	Output Speed (rpm)	Tractive Effort (lb)	Drawbar Pull (lb)	Wheel Power Available (hp)	Net Grade (%)	Transmission Heat Rejection (BTU/min)	Match Point
1C	0.0	1728	0	13651.16	13481.07	0.0	35.68	15599.03	
1C	2.0	1774	70	13623.10	13448.43	72.7	35.58	12686.27	
1C	4.0	1863	139	13553.54	13373.07	144.6	35.36	10004.21	
1C	6.0	1931	209	12682.02	12494.52	202.9	32.78	7214.21	
1C	8.0	1984	278	11293.22	11097.47	240.9	28.79	5371.88	
1C	8.2	1991	285	11175.04	10978.43	244.1	28.45	5210.90	70 Percent
1C	10.0	2054	348	10133.59	9928.36	270.2	25.55	4100.22	
1C	10.9	2091	380	9643.98	9433.95	281.0	24.20	3676.80	80 Percent
1C	12.0	2131	418	8965.39	8749.46	286.9	22.35	3143.21	
1C	13.0	2165	451	8308.74	8087.17	287.4	20.58	2806.87	85 Percent
1C	13.6	2189	473	7909.39	7684.08	286.7	19.52	2626.46	
2C	13.6	1960	473	6315.47	6090.15	228.9	15.36	5971.94	
2C	14.0	1967	487	6241.02	6013.17	233.0	15.16	5770.02	
2C	16.0	2003	557	5888.87	5647.87	251.3	14.22	4871.82	
2C	18.0	2041	626	5559.04	5303.66	266.8	13.34	4230.91	
2C	20.0	2082	696	5250.76	4979.79	280.0	12.51	3702.26	
2C	22.0	2122	766	4911.22	4623.43	288.1	11.60	3162.82	
2C	22.7	2136	791	4768.28	4474.07	289.0	11.22	3001.68	
2L	22.7	1475	791	4792.47	4498.26	290.5	11.28	296.95	
2L	24.0	1557	835	4779.57	4473.74	305.9	11.22	310.23	
2L	26.0	1687	905	4752.60	4427.51	329.5	11.11	337.99	
2L	28.0	1817	974	4718.77	4373.19	352.3	10.97	366.64	
2L	30.0	1947	1044	4413.70	4046.41	353.1	10.14	377.36	
2L	32.0	2076	1114	4131.64	3741.41	352.6	9.37	408.67	
2L	32.8	2125	1140	3988.67	3589.45	348.4	8.98	407.24	
3L	32.8	1607	1140	3612.90	3213.69	315.6	8.04	293.94	
3L	34.0	1668	1183	3602.43	3188.04	326.6	7.97	306.63	
3L	36.0	1766	1253	3583.63	3143.86	344.0	7.86	326.53	
3L	38.0	1864	1323	3530.83	3064.46	357.8	7.66	346.87	
3L	40.0	1962	1392	3307.97	2813.76	352.8	7.03	353.13	
3L	42.0	2060	1462	3148.80	2625.55	352.7	6.56	376.43	
3L	43.3	2125	1508	3020.60	2477.36	349.0	6.19	380.23	

4L	43.3	1508	1508	2590.27	2047.02	299.3	5.11	187.09	
4L	44.0	1531	1531	2587.97	2034.43	303.7	5.08	189.73	
4L	46.0	1601	1601	2581.12	1996.09	316.6	4.98	199.49	
4L	48.0	1671	1671	2572.54	1954.78	329.3	4.88	210.45	
4L	50.0	1740	1740	2563.08	1911.38	341.7	4.77	221.28	
4L	52.0	1810	1810	2552.97	1866.10	354.0	4.66	233.74	
4L	54.0	1879	1879	2495.34	1772.07	359.3	4.42	244.85	
4L	56.0	1949	1949	2382.78	1621.90	355.8	4.05	247.93	
4L	58.0	2019	2019	2285.20	1485.47	353.4	3.71	270.50	
4L	60.0	2088	2088	2223.30	1383.51	355.7	3.45	285.84	
4L	61.1	2125	2125	2157.15	1295.67	351.2	3.23	282.11	
5L	61.1	1593	2125	1915.65	1054.18	311.9	2.63	347.64	
5L	62.0	1618	2158	1913.39	1032.32	316.3	2.57	354.26	
5L	64.0	1670	2227	1908.37	984.79	325.7	2.46	369.25	
5L	66.0	1722	2297	1902.99	935.67	334.9	2.33	384.28	
5L	68.0	1774	2367	1897.12	884.84	344.0	2.21	398.80	
5L	70.0	1827	2436	1891.23	832.77	353.0	2.08	416.27	
5L	72.0	1879	2506	1850.56	744.70	355.3	1.86	427.97	
5L	74.0	1931	2575	1787.12	632.63	352.7	1.58	432.66	
5L	76.0	1983	2645	1725.18	520.83	349.6	1.30	449.69	
5L	78.0	2035	2715	1681.67	426.25	349.8	1.06	464.83	
5L	80.0	2088	2784	1646.87	339.16	351.3	0.85	483.90	
5L	82.0	2140	2854	1572.48	211.24	343.8	0.53	481.34	
5L	84.0	2192	2923	1485.77	69.79	332.8	0.17	505.85	
5L	85.5	2230	2974	1381.88	-74.73	314.9	-0.19	516.79	Governed
5L	86.0	2244	2993	1236.50	-235.45	283.6	-0.59	472.25	
5L	88.0	2296	3063	702.23	-826.92	164.8	-2.06	472.83	
5L	90.0	2349	3132	167.05	-1420.52	40.1	-3.54	337.43	
5L	90.6	2365	3154	0.00	-1606.04	0.0	-4.01	339.00	

PLOTS - FULL THROTTLE AUTOMATIC UPSHIFTS (1C-2C-2L-3L-4L-5L-6L) - STANDARD, FAN ON, AC OFF, AXLE RATIO = 4.330, AL▲

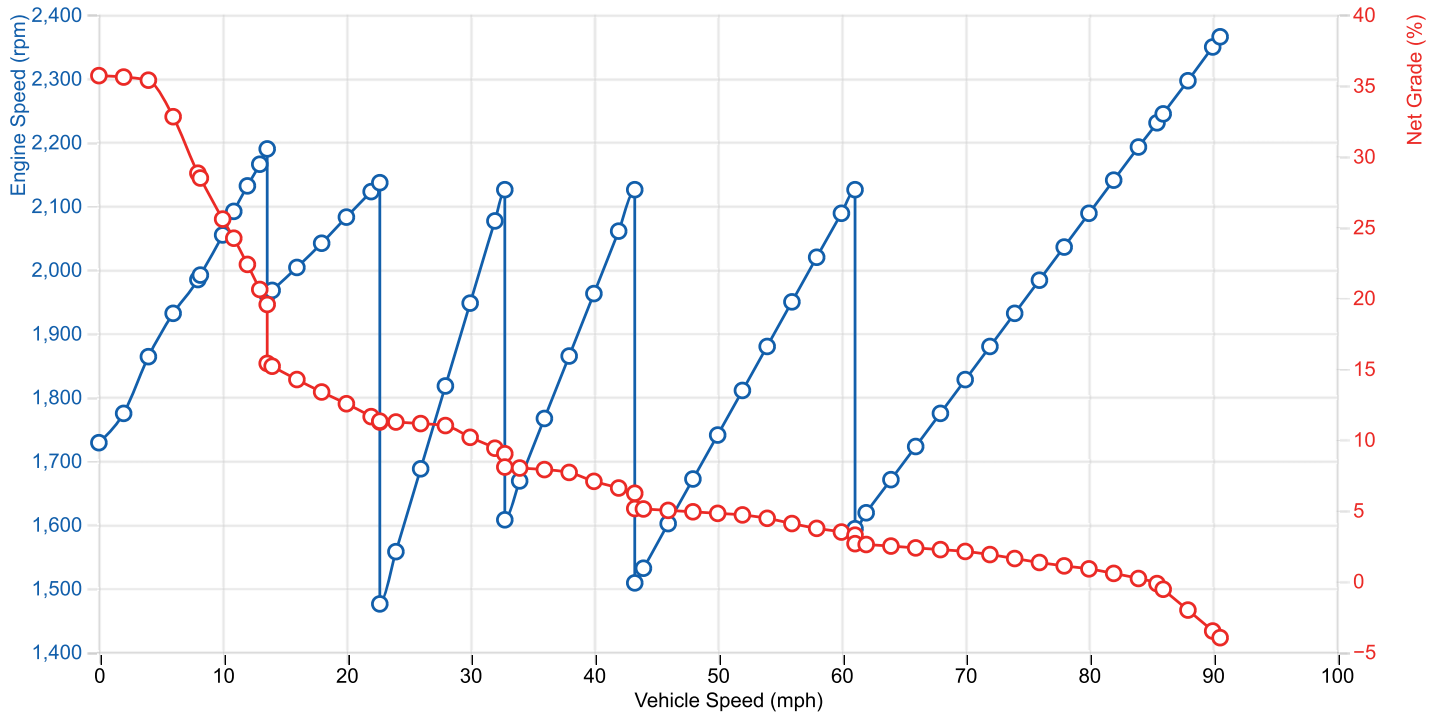

- FULL THROTTLE MANUAL 1ST HOLD - LOCKUP APPLY (1C-1L) - STANDARD, FAN ON, AC OFF, AXLE RATIO = 4.330, AUX RATIO = 1.000, ST/PTO**
- PLOTS - FULL THROTTLE MANUAL 1ST HOLD - LOCKUP APPLY (1C-1L) - STANDARD, FAN ON, AC OFF, AXLE RATIO = 4.330, AUX RATIO = 1.000, ST/PTO**
- FULL THROTTLE REVERSE PERFORMANCE (1C-1C) - STANDARD, FAN ON, AC OFF, AXLE RATIO = 4.330, AUX RATIO = 1.000, ST/PTO**
- PLOTS - FULL THROTTLE REVERSE PERFORMANCE (1C-1C) - STANDARD, FAN ON, AC OFF, AXLE RATIO = 4.330, AUX RATIO = 1.000, ST/PTO**

Vehicle Acceleration Performance ▲

MISSION ▲	
End User	Nederland Fire Protection District (North America, Western)
Selected Vocation	Fire Service — Pumper - with Split Shaft PTO — Straight Truck (20-20-10)
PLATFORM ▲	

Vehicle Manufacturer	Pierce Manufacturing (North America)
Vehicle Model	152" Pumper AL 4x4
Vehicle Configuration	Saber Fr
Engine Description	Cummins L9 (Diesel) -- 450hp / 1250lbft / 2200rpm -- (EPA21) (2-L008627-E, Rev B)
Transmission	3000 EVS (1-L007339-T, Rev E)
Transmission Rating	3000 EVS Fire Truck, Emergency Vehicle - Diesel Allison 6th Generation Controls with SEM/LRTP (1-L018780-R, Rev A)
Vehicle Parameters	Standard
Torque Converter	TC421 (1-L001255-TC, Rev C) Acceptable
Transmission Retarder	
LRTP Status	LRTP Required

NOTE

This SCAAN information is subject to the SCAAN Disclaimer set forth elsewhere.

The ■ symbol indicates that Wheel Slip may occur.

Initial conditions for this report are Service Brakes locked and Engine at Full Throttle.

FULL THROTTLE AUTOMATIC UPSHIFTS (1C-2C-2L-3L-4L-5L-6L) - STANDARD, FAN ON, AC OFF, AXLE RATIO = 4.330, AUX RATIO▲

Engine Fan	On	Engine Power	Standard Power Curve						
Air Conditioning	Off	Vehicle Parameters	Standard						
Axle Ratio	4.330	Auxiliary Gearing Ratio	1.000						
Grade	0.00%								
Gear Range	Vehicle Speed (mph)	Time (seconds)	Distance (ft)	Acceleration Rate (mph/sec)	Engine Speed (rpm)	Tractive Effort (lb)	Drawbar Pull (lb)	Wheel Power Available (hp)	Transmission Heat Rejection (BTU/min)
1C	2.0	0.3	0	6.933	1774	13623.10	13448.43	72.7	12686.27
1C	4.0	0.6	2	6.837	1863	13553.54	13373.07	144.6	10004.21
1C	6.0	0.9	4	6.557	1931	12682.02	12494.52	202.9	7214.21
1C	8.0	1.2	7	5.744	1984	11293.22	11097.47	240.9	5371.88
1C	10.0	1.6	12	5.135	2054	10133.59	9928.36	270.2	4100.22
1C	12.0	2.0	19	4.537	2131	8965.39	8749.46	286.9	3143.21
1C	13.6	2.4	26	3.978	2189	7909.39	7684.08	286.7	2626.46
2C	14.0	2.5	29	3.199	1967	6241.02	6013.17	233.0	5770.02
2C	16.0	3.1	43	3.003	2003	5888.87	5647.87	251.3	4871.82
2C	18.0	3.8	60	2.819	2041	5559.04	5303.66	266.8	4230.91
2C	20.0	4.6	80	2.644	2082	5250.76	4979.79	280.0	3702.26
2C	22.0	5.3	105	2.460	2122	4911.22	4623.43	288.1	3162.82
2C	22.7	5.6	114	2.380	2136	4768.28	4474.07	289.0	3001.68
2L	24.0	6.2	133	2.339	1557	4779.57	4473.74	305.9	310.23
2L	26.0	7.0	165	2.314	1687	4752.60	4427.51	329.5	337.99
2L	28.0	7.9	199	2.286	1817	4718.77	4373.19	352.3	366.64

2L	30.0	8.8	237	2.121	1947	4413.70	4046.41	353.1	377.36
2L	32.0	9.8	282	1.959	2076	4131.64	3741.41	352.6	408.67
2L	32.8	10.2	301	1.886	2125	3990.19	3591.05	348.5	407.34
3L	34.0	10.9	337	1.686	1668	3602.43	3188.04	326.6	306.63
3L	36.0	12.1	398	1.663	1766	3583.63	3143.86	344.0	326.53
3L	38.0	13.3	464	1.624	1864	3530.83	3064.46	357.8	346.87
3L	40.0	14.6	538	1.492	1962	3307.97	2813.76	352.8	353.13
3L	42.0	16.0	622	1.390	2060	3148.80	2625.55	352.7	376.43
3L	43.3	17.0	683	1.313	2125	3020.60	2477.36	349.0	380.23
4L	44.0	17.6	723	1.084	1531	2587.97	2034.43	303.7	189.73
4L	46.0	19.5	846	1.064	1601	2581.12	1996.09	316.6	199.49
4L	48.0	21.4	977	1.042	1671	2572.54	1954.78	329.3	210.45
4L	50.0	23.3	1117	1.019	1740	2563.08	1911.38	341.7	221.28
4L	52.0	25.3	1265	0.995	1810	2552.97	1866.10	354.0	233.74
4L	54.0	27.4	1425	0.946	1879	2495.34	1772.07	359.3	244.85
4L	56.0	29.6	1603	0.866	1949	2382.78	1621.90	355.8	247.93
4L	58.0	32.0	1806	0.793	2019	2285.20	1485.47	353.4	270.50
4L	60.0	34.6	2033	0.739	2088	2223.30	1383.51	355.7	285.84
4L	61.1	36.1	2164	0.692	2125	2157.15	1295.67	351.2	282.11
5L	62.0	37.8	2317	0.553	1618	1913.39	1032.32	316.3	354.26
5L	64.0	41.5	2659	0.527	1670	1908.37	984.79	325.7	369.25
5L	66.0	45.4	3031	0.501	1722	1902.99	935.67	334.9	384.28
5L	68.0	49.5	3435	0.474	1774	1897.12	884.84	344.0	398.80
5L	70.0	53.9	3876	0.446	1827	1891.23	832.77	353.0	416.27
5L	72.0	58.6	4366	0.400	1879	1850.56	744.70	355.3	427.97
5L	74.0	64.0	4950	0.340	1931	1787.12	632.63	352.7	432.66
5L	76.0	70.5	5666	0.280	1983	1725.18	520.83	349.6	449.69
5L	78.0	78.5	6566	0.229	2035	1681.67	426.25	349.8	464.83
5L	80.0	88.3	7704	0.183	2088	1646.87	339.16	351.3	483.90
5L	82.0	102.0	9325	0.115	2140	1572.48	211.24	343.8	481.34
5L	84.0	131.2	12894	0.040	2192	1485.77	69.79	332.8	505.85

PLOTS - FULL THROTTLE AUTOMATIC UPSHIFTS (1C-2C-2L-3L-4L-5L-6L) - STANDARD, FAN ON, AC OFF, AXLE RATIO = 4.330, AL▲

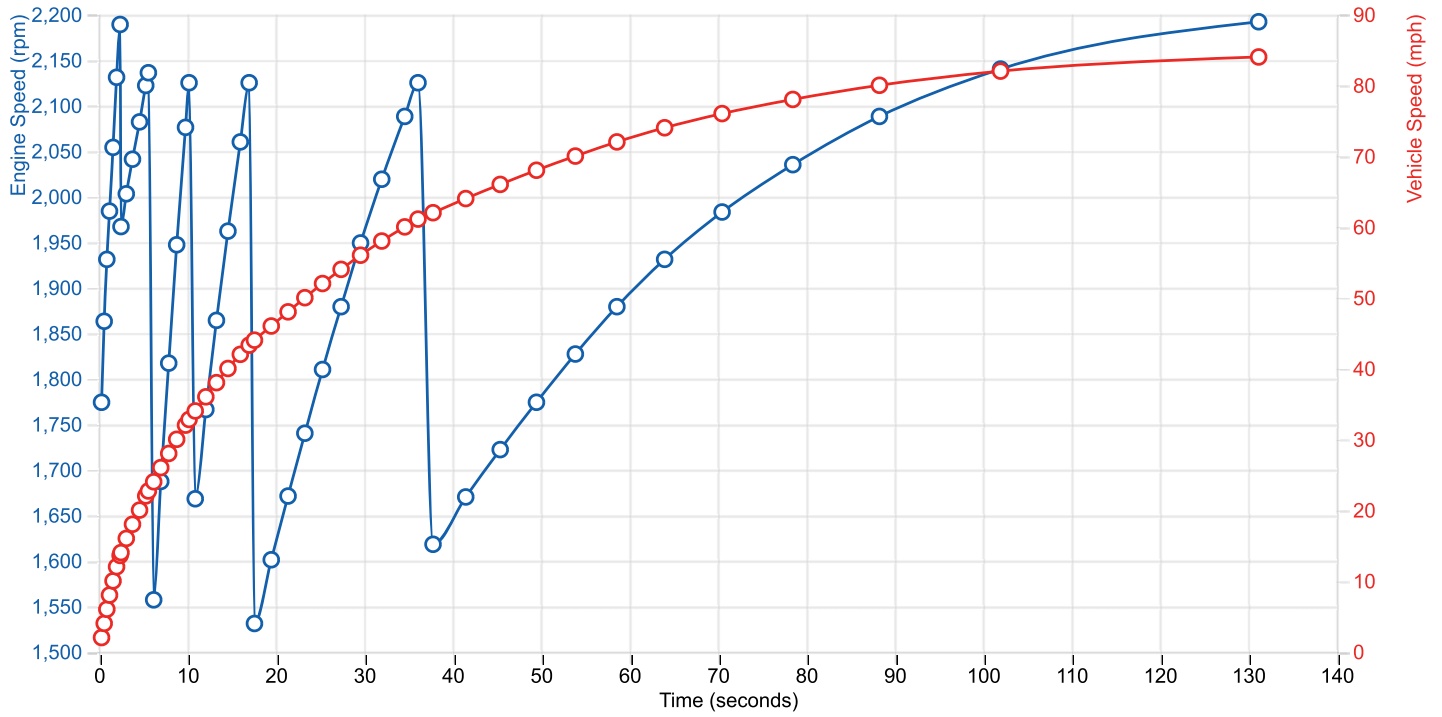

- FULL THROTTLE MANUAL 1ST HOLD - LOCKUP APPLY (1C-1L) - STANDARD, FAN ON, AC OFF, AXLE RATIO = 4.330, AUX RATIO = 1.000, ST/▼
- PLOTS - FULL THROTTLE MANUAL 1ST HOLD - LOCKUP APPLY (1C-1L) - STANDARD, FAN ON, AC OFF, AXLE RATIO = 4.330, AUX RATIO = 1.000, ST/▼
- FULL THROTTLE REVERSE PERFORMANCE (1C-1C) - STANDARD, FAN ON, AC OFF, AXLE RATIO = 4.330, AUX RATIO = 1.000, ST/▼
- PLOTS - FULL THROTTLE REVERSE PERFORMANCE (1C-1C) - STANDARD, FAN ON, AC OFF, AXLE RATIO = 4.330, AUX RATIO = 1.000, ST/▼

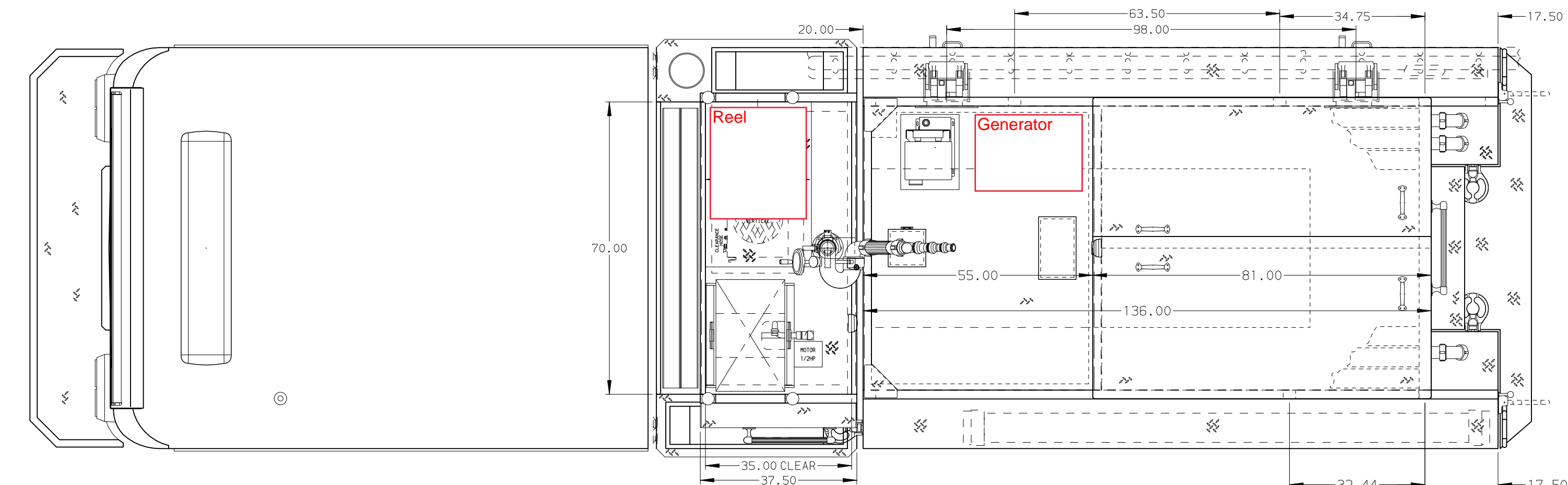
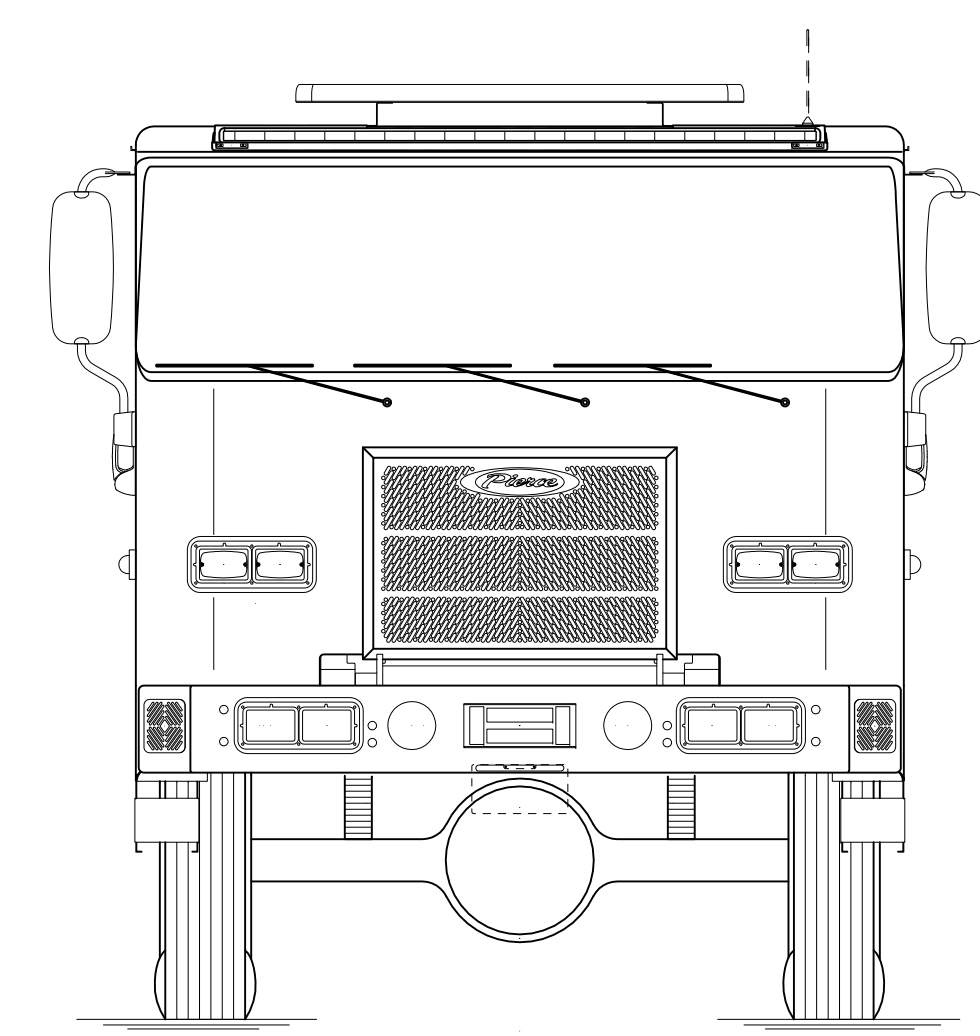
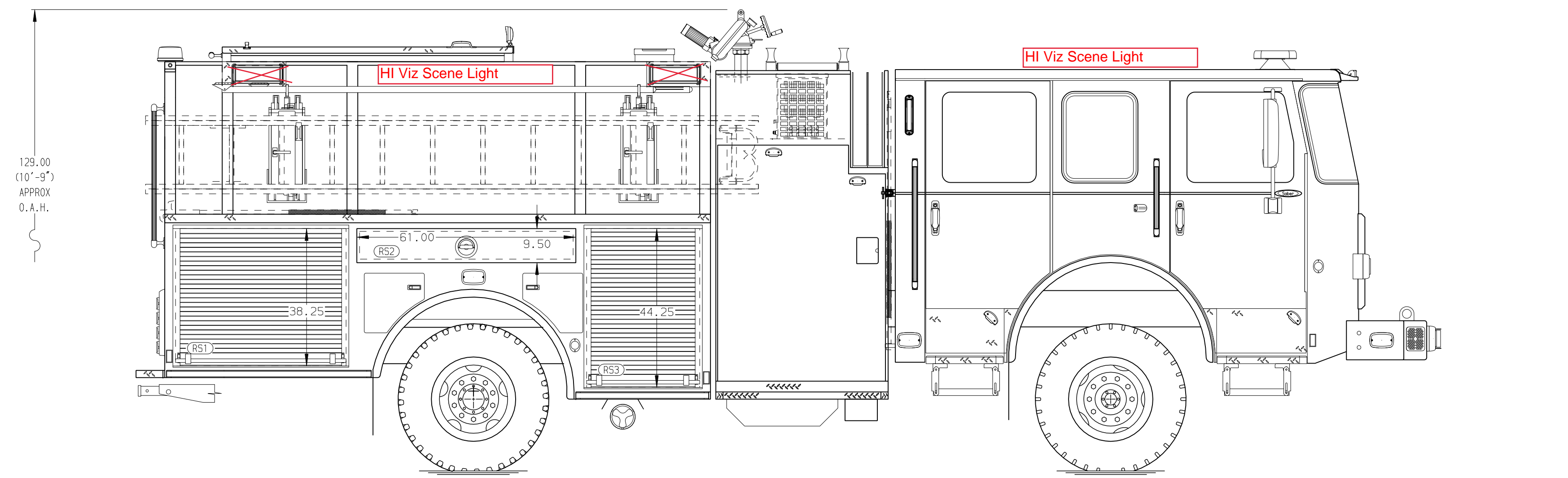

- HOSEBED CAPACITIES
- ① - 400' OF 3.00" D.J. POLY HOSE
 - ② - 1000' OF 5.00" L.D.H. HOSE
 - ③ - 400' OF 2.50" D.J. POLY HOSE

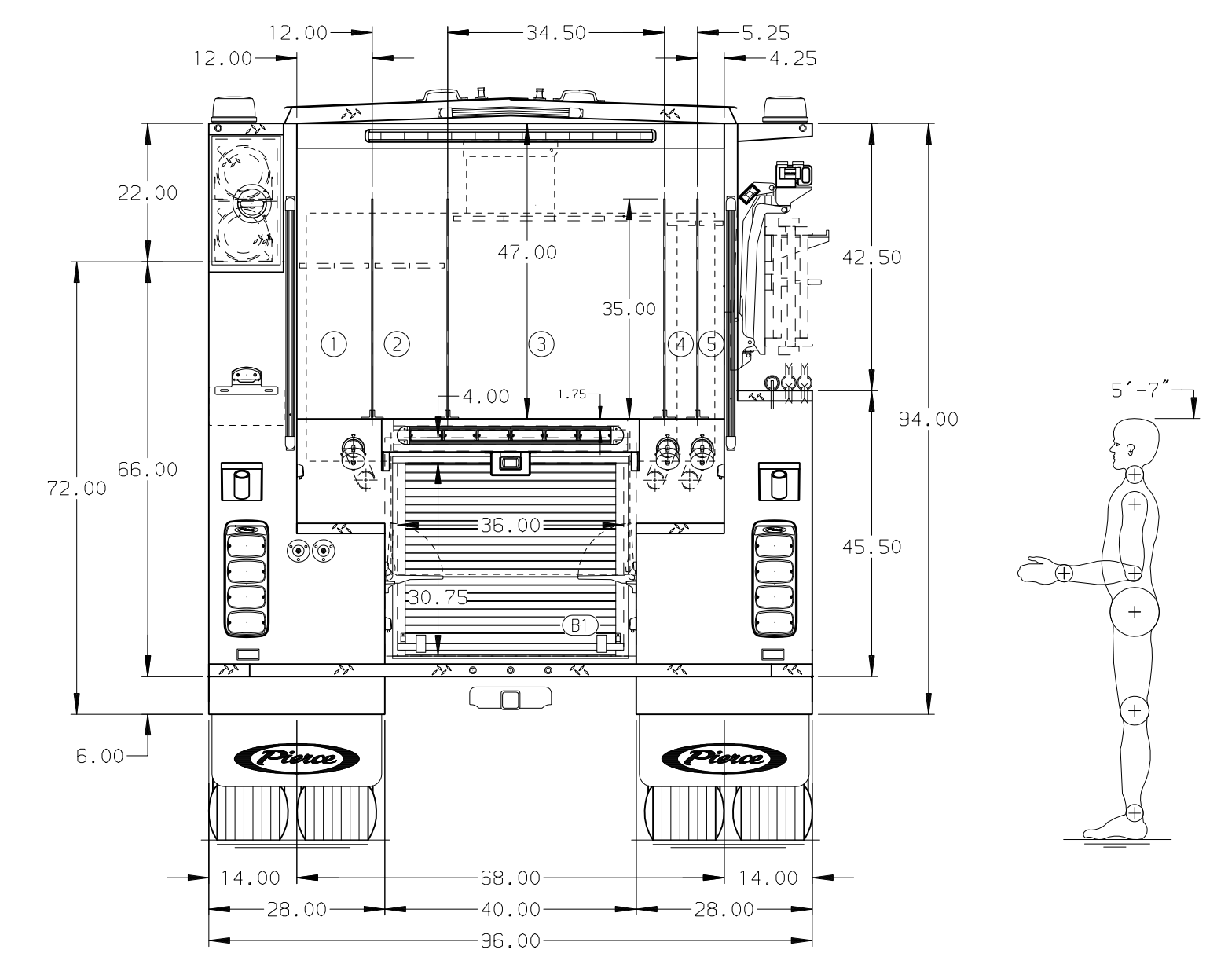
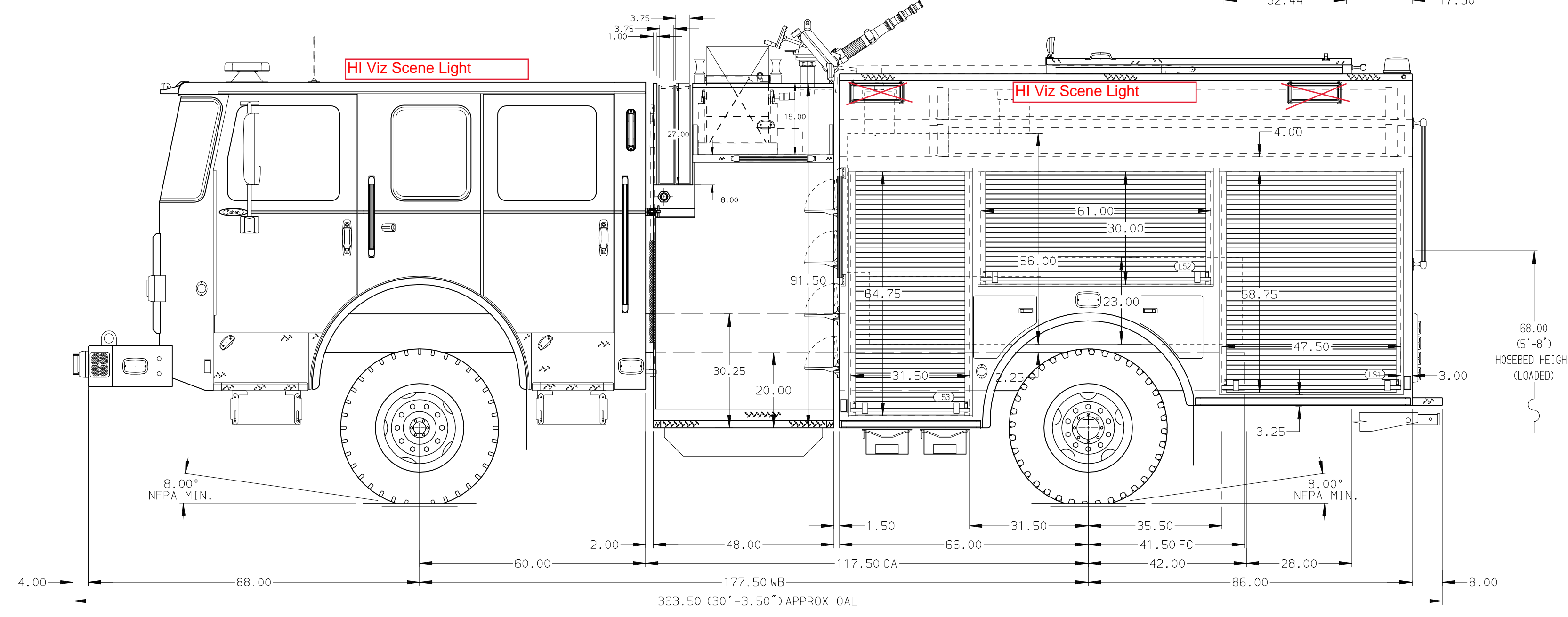

ALUMINUM BODY

NOTE
DIMENSIONS SHOWN ARE APPROXIMATE AND ARE SUBJECT TO MINOR DEVIATIONS AS MAY OCCUR OR BE NECESSARY IN CONSTRUCTION. MINOR DETAILS NOT SHOWN.

CUSTOMER APPROVAL			
APPROVED BY:			
DATE:			
REV	DATE	BY	CH
22APR22	CKN	AM1	

Pierce MANUFACTURING INC.

TITLE: 1250-D-750P, 730G WATER, 20G FOAM, 152" FDLER BODY
LADDERS BTWN TANK & SS, (3) XLAYS, GENERATOR, DELUGE
FOR: NEDERLAND FIRE PROTECTION DISTRICT BID# 1177
FRONT RANGE FIRE APPARATUS, LTD JASON BYRNE

DWG NO. 05-0322

JOB NO.	PRELIM
SCALE	1:24
DATE	
DRAWN BY	JJB
CHECKED BY	CKN
SHEET NO.	1 OF 1



Fire and Rescue Apparatus

One (1) Year Material and Workmanship

Basic Apparatus

Limited Warranty

1. LIMITED WARRANTY

Subject to the limitations and exclusions set forth below, Pierce Manufacturing provides the following warranty to the Buyer:

Coverage:	Portions of the apparatus manufactured by Pierce shall be free from defects in material and workmanship
Warranty Begins:	The date the apparatus is placed in service, or 60 days from the original buyer invoice date, whichever comes first.
Warranty Period Ends After:	Twelve (12) months.
Conditions and Exclusions: See Also Paragraphs 2 thru 4	No specific exclusions apply

This limited warranty shall apply only if the product is properly maintained in accordance with Pierce's maintenance instructions and manuals and is used in service which is normal to the particular model. Normal service means service which does not subject the product to stresses or impacts greater than normally result from careful use. If the Buyer discovers a defect or nonconformity, it must notify Pierce in writing within thirty (30) days after the date of discovery, but in any event prior to the expiration of the warranty period. THIS LIMITED WARRANTY MAY NOT BE ASSIGNED OR OTHERWISE TRANSFERRED BY THE BUYER TO ANY SUBSEQUENT USER OR PURCHASER OR TO ANY OTHER PERSON OR ENTITY.

Notwithstanding anything to the contrary herein, Pierce makes no warranty whatsoever as to:

(a) any integral parts, components, attachments or trade accessories of or to the product that are not manufactured by Pierce, including but not limited to engines, transmissions, drivelines, axles, water pumps and generators; with respect to all such parts, components, attachments and accessories, Pierce shall assign to Buyer the applicable warranties, if any, made by the respective manufacturers thereof;

(b) any vehicle, chassis, or component, part, attachment or accessory damaged by misuse, neglect, fire, exposure to severe environmental or chemical conditions, acidic environment, improper maintenance, accident, crash, or force majeure such as natural disaster, lightning, earthquake, windstorm, hail, flood, war or riot;

(c) any vehicle, chassis or component, part, attachment or accessory that has been repaired, altered or assembled in any way by any person or entity other than Pierce which, in the sole judgment of Pierce, adversely affects the performance, stability or purpose for which it was manufactured; or

(d) products or parts which may in the ordinary course wear out and have to be replaced during the warranty period, including, but not limited to, tires, fluids, gaskets and light bulbs. Pierce assumes no responsibility for the assembly of its parts or subassemblies into finishing products or vehicles unless the assembly is performed by Pierce.

The original purchaser may void this warranty in part or in its entirety if the product is repaired or replaced (a) without prior written approval of the Pierce Customer Service Department; or (b) at a facility which has not been approved by Pierce as to technical capability. Any repairs, modifications, alterations or aftermarket parts added after manufacture without the authorization of Pierce may void this warranty.

2. DISCLAIMERS OF WARRANTIES

THE WARRANTY SET FORTH IN PARAGRAPH 1 IS THE SOLE AND EXCLUSIVE WARRANTY GIVEN BY PIERCE. PIERCE HEREBY DISCLAIMS AND EXCLUDES ALL OTHER WARRANTIES, WHETHER EXPRESS, IMPLIED OR STATUTORY, INCLUDING WITHOUT LIMITATION ANY WARRANTY OF MERCHANTABILITY, ANY WARRANTY OF FITNESS FOR A PARTICULAR PURPOSE, AND ANY WARRANTIES ARISING FROM COURSE OF DEALING OR USAGE OF TRADE.

3. BUYER'S EXCLUSIVE REMEDY

If the product fails to conform to the warranty set forth in paragraph 1 during the warranty period, and such nonconformity is not due to misuse, neglect, accident or improper maintenance, Buyer must notify Pierce within the time period specified in paragraph 1, and shall make the product available for inspection by Pierce or its designated agent. At the request of Pierce, any allegedly defective product shall be returned to Pierce by Buyer for examination and/or repair. Buyer shall be responsible for the cost of such transportation, and for risk of loss of or damage to the product during transportation. Within a reasonable time, Pierce shall repair or replace (at Pierce's option and expense) any nonconforming or defective parts. Repair or replacement shall be made only by a facility approved in advance in writing by Pierce. THIS REMEDY SHALL BE THE EXCLUSIVE AND SOLE REMEDY FOR ANY BREACH OF WARRANTY.

4. EXCLUSION OF CONSEQUENTIAL AND INCIDENTAL DAMAGES

Notwithstanding anything to the contrary herein or in any agreement between Pierce and Buyer, IN NO EVENT SHALL PIERCE BE LIABLE FOR ANY CONSEQUENTIAL, INCIDENTAL, SPECIAL, INDIRECT, OR PUNITIVE DAMAGES WHATSOEVER, WHETHER ARISING OUT OF BREACH OF CONTRACT, WARRANTY, TORT (INCLUDING NEGLIGENCE AND STRICT LIABILITY) OR OTHER THEORY OF LAW OR EQUITY, WITH RESPECT TO VEHICLES OR OTHER PRODUCTS SOLD BY PIERCE, OR THEIR OPERATION OR FAILURE TO OPERATE, OR ANY DEFECTS THEREIN, OR ANY UNDERTAKINGS, ACTS OR OMISSIONS RELATED THERETO, REGARDLESS OF WHETHER PIERCE HAS BEEN INFORMED OF THE POSSIBILITY OF ANY SUCH DAMAGES. Without limiting the generality of the foregoing, Pierce specifically disclaims any liability for property or personal injury damages, penalties, damages for lost profits or revenues, loss of vehicles or products or any associated equipment, cost of substitute vehicles or products, down-time, delay damages, any other types of economic loss, or for any claims by any third party for any such damages.

Note: Any Surety Bond, if a part of the sale of the vehicle as to which this limited warranty is provided, applies only to this Pierce Basic One Year Limited Warranty for such vehicle, and not to other warranties made by Pierce in a separate document (if any) or to the warranties (if any) made by any manufacturer (other than Pierce) of any part, component, attachment or accessory that is incorporated into or attached to the vehicle.



Cummins Warranty

Worldwide

Fire Apparatus/Crash Trucks

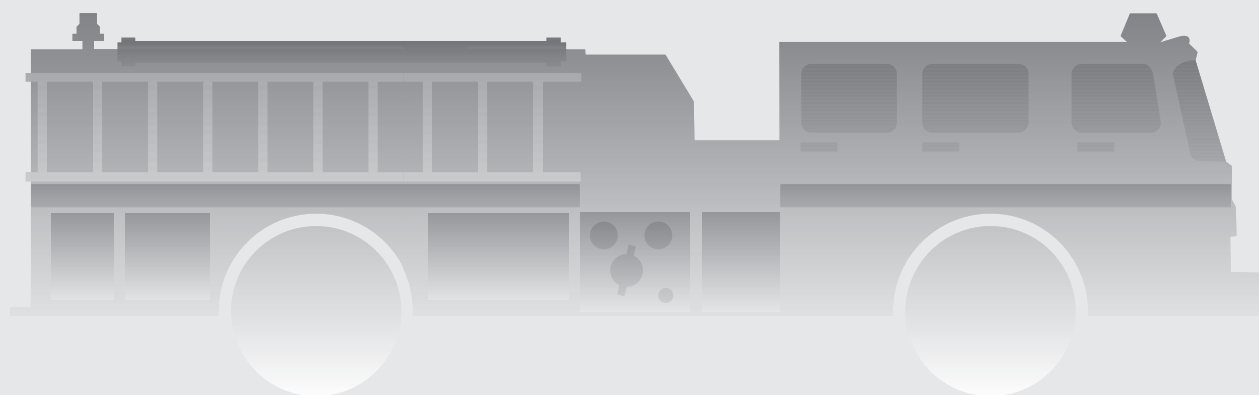

Coverage

Products Warranted

This Warranty applies to new diesel Engines sold by Cummins and delivered to the first user on or after April 1, 2007, that are used in fire apparatus truck and crash truck* applications Worldwide.

Base Engine Warranty

The Base Engine Warranty covers any failures of the Engine which result, under normal use and service, from a defect in material or factory workmanship (Warrantable Failure). This Coverage begins with the sale of the Engine by Cummins and ends five years or 100,000 miles (160,935 kilometers), whichever occurs first, after the date of delivery of the Engine to the first user.

Engine aftertreatment components included in the Cummins Critical Parts List (CPL) and marked with a Cummins part number are covered under Base Engine Warranty.

Additional Coverage is outlined in the Emission Warranty section.

These Warranties are made to all Owners in the chain of distribution and Coverage continues to all subsequent Owners until the end of the periods of Coverage.

Cummins Responsibilities

Cummins will pay for all parts and labor needed to repair the damage to the Engine resulting from a Warrantable Failure.

Cummins will pay for the lubricating oil, antifreeze, filter elements, belts, hoses and other maintenance items that are not reusable due to the Warrantable Failure.

Cummins will pay for reasonable labor costs for Engine removal and reinstallation when necessary to repair a Warrantable Failure.

Cummins will pay reasonable costs for towing a vehicle disabled by a Warrantable Failure to the nearest authorized repair location. In lieu of the towing expense, Cummins will pay reasonable costs for mechanics to travel to and from the location of the vehicle, including meals, mileage and lodging when the repair is performed at the site of the failure.

Owner Responsibilities

Owner is responsible for the operation and maintenance of the Engine as specified in Cummins Operation and Maintenance Manuals. Owner is also responsible for providing proof that all recommended maintenance has been performed.

Before the expiration of the applicable Warranty, Owner must notify a Cummins distributor, authorized dealer or other repair location approved by Cummins of any Warrantable Failure and make the Engine available for repair by such facility. Except for Engines disabled by a Warrantable Failure, Owner must also deliver the Engine to the repair facility.

Service locations are listed on the Cummins Worldwide Service Locator at cummins.com.

Owner is responsible for the cost of lubricating oil, antifreeze, filter elements and other maintenance items provided during Warranty repairs unless such items are not reusable due to the Warrantable Failure.

Owner is responsible for communication expenses, meals, lodging and similar costs incurred as a result of a Warrantable Failure.

Owner is responsible for non-Engine repairs and for "downtime" expenses, cargo damage, fines, all applicable taxes, all business costs and other losses resulting from a Warrantable Failure.

Owner is responsible for a \$100 (U.S. Dollars) deductible per each service visit under this plan in the 3rd, 4th and 5th years of Base Engine Warranty. The deductible will not be charged during the first 2 years of the Base Engine Warranty.

Limitations

Cummins is not responsible for failures or damage resulting from what Cummins determines to be abuse or neglect, including, but not limited to: operation without adequate coolants or lubricants; overfueling; overspeeding; lack of maintenance of lubricating, cooling or intake systems; improper storage, starting, warm-up, run-in or shutdown practices; unauthorized modifications of the Engine.

Any unauthorized modifications to the aftertreatment could negatively effect emissions certification and void Warranty.

Cummins is also not responsible for failures caused by incorrect oil, fuel or diesel exhaust fluid or by water, dirt or other contaminants in the fuel, oil or diesel



exhaust fluid.

This Warranty does not apply to accessories supplied by Cummins which bear the name of another company. Such non-warranted accessories include, but are not limited to: alternators, starters, fans, air conditioning compressors, clutches, filters, transmissions, torque converters, vacuum pumps, power steering pumps, fan drives and air compressors. Cummins branded alternators and starters are covered for the first two years from the date of delivery of the Engine to the first user, or the expiration of the Base Engine Warranty, whichever occurs first.

Failures resulting in excessive oil consumption are not covered beyond the duration of the Coverage or 100,000 miles (160,935 kilometers) or 7,000 hours from the date of delivery of the Engine to the first user, whichever of the three occurs first. Before a claim for excessive oil consumption will be considered, Owner must submit adequate documentation to show that consumption exceeds Cummins published standards.

Failures of belts and hoses supplied by Cummins are not covered beyond the first year from the date of delivery of the Engine to the first user or the duration of the Warranty, whichever occurs first.

Parts used to repair a Warrantable Failure may be new Cummins parts, Cummins approved rebuilt parts or repaired parts. Cummins is not responsible for failures resulting from the use of parts not approved by Cummins.

A new Cummins or Cummins approved rebuilt part used to repair a Warrantable Failure assumes the identity of the part it replaced and is entitled to the remaining Coverage hereunder.

Cummins Inc. reserves the right to interrogate Electronic Control Module (ECM) data for purposes of failure analysis.

CUMMINS DOES NOT COVER WEAR OR WEAROUT OF COVERED PARTS.

CUMMINS IS NOT RESPONSIBLE FOR INCIDENTAL OR CONSEQUENTIAL DAMAGES.

THIS WARRANTY AND THE EMISSION WARRANTY SET FORTH HEREINAFTER ARE THE SOLE WARRANTIES MADE BY CUMMINS IN REGARD TO THESE ENGINES. CUMMINS MAKES NO OTHER WARRANTIES, EXPRESS OR IMPLIED, OR OF MERCHANTABILITY OR FITNESS FOR A PARTICULAR PURPOSE.

This Warranty gives you specific legal rights, and you may also have other rights which vary from state to state.

Emission Warranty

Products Warranted

This Emission Warranty applies to new Engines marketed by Cummins that are used in the United States** in vehicles designed for transporting persons or property on a street or highway. This Warranty applies to Engines delivered to the first user on or after September 1, 1992.

Coverage

Cummins warrants to the first user and each subsequent purchaser that the Engine is designed, built and equipped so as to conform at the time of sale by Cummins with all U.S. federal emission regulations applicable at the time of manufacture and that it is free from defects in material or factory workmanship which would cause it not to meet these regulations within the longer of the following periods: (A) Five years or 100,000 miles (160,935 kilometers) of operation, whichever occurs first, as measured from the date of delivery of the Engine to the first user or (B) The Base Engine Warranty.

If the vehicle in which the Engine is installed is registered in the state of California, a separate California Emission Warranty also applies.

Limitations

Failures, other than those resulting from defects in material or factory workmanship, are not covered by this Warranty.

Cummins is not responsible for failures or damage resulting from what Cummins determines to be abuse or neglect, including, but not limited to: operation without adequate coolants or lubricants; overfueling; overspeeding; lack of maintenance of lubricating, cooling or intake systems; improper storage, starting, warm-up, run-in or shutdown practices; unauthorized modifications of the Engine.

Any unauthorized modifications to the aftertreatment could negatively effect emissions certification and void Warranty.

Cummins is also not responsible for failures caused by incorrect oil, fuel or diesel exhaust fluid or by water, dirt or other contaminants in the fuel, oil or diesel exhaust fluid.

Cummins is not responsible for non-Engine repairs, "downtime" expenses, cargo damage, fines, all applicable taxes, all business costs or other losses resulting from a Warrantable Failure.

**CUMMINS IS NOT RESPONSIBLE FOR INCIDENTAL
OR CONSEQUENTIAL DAMAGES.**

* Airport operated crash trucks and fire department operated trucks employed to respond to fires, hazardous material releases, rescue and other emergency-type situations.

** United States includes American Samoa, the Commonwealth of Northern Mariana Islands, Guam, Puerto Rico and the U.S. Virgin Islands.



Cummins Inc.
Box 3005
Columbus, IN 47202-3005
U.S.A.

Bulletin 3381161
Printed in U.S.A. Rev. 08/09
©2001 Cummins Inc.

TRW COMMERCIAL STEERING SYSTEMS
800 HEATH STREET
LAFAYETTE, INDIANA 47904



PRODUCT WARRANTY

- I. WARRANTY:** The Commercial Steering Systems group of TRW, Inc., hereinafter referred to as "CSS", warrants that each new product supplied by CSS to its customer, when properly installed, used and maintained, shall be free from defect in material and workmanship for the period specified below:
- (A) CSS Product installed in **New On-highway Motor Vehicle:**
- Within twelve (12) months after date of delivery of such vehicle to the original retail purchaser, or before such vehicle has been driven one hundred thousand (100,000) miles, whichever event shall first occur.
- (B) CSS Product installed in **New Agricultural, Turf, Industrial, or Construction Vehicles and Related Equipment**
- Within twelve (12) months after date of delivery of such vehicle/equipment to the original retail purchaser or before such vehicle/equipment has been operated for two thousand (2000) hours or fifty thousand (50,000) miles, whichever occurs first.
- (C) CSS Product installed in **New End Product, Not Specifically Mentioned in Classifications (A) or (B) Above and All Other Off-Highway/Severe Applications:**
- Within six (6) months after date of delivery of the original equipment manufacturer's end product to the original retail purchaser.
- II. REMEDY:** Customer's sole remedy under the foregoing warranty is limited to correction by means of repair, replacement or issuance of credit, at the option of CSS, of any product which is:
- (A) Returned to CSS within the specified warranty time period, with prior notice to, and the written consent of, CSS, with transportation and handling charges prepaid, together with a statement describing the alleged defect, the part number, model number and application, and mileage or hours of use of such product; and
- (B) Upon examination, determined by CSS not to conform to the warranty.
- III.** Any product which is repaired or replaced under this warranty will be returned to customer prepaid. Disposition of any product determined not to be covered by this warranty will be at the customer's expense.
- IV.** CSS will not be liable for any repairs, replacements, or adjustments to any product or any cost of labor performed by or at the request of customer without the express prior written consent of CSS.
- V. EXCEPTIONS:** The provision of this warranty shall not apply to any CSS product which is used for a purpose for which it is not designed, or which shall have been repaired or altered in any way, or which has been subject to misuse, negligence or accident, neglect of normal maintenance services, so as, in the judgement of CSS to adversely affect its performance and reliability. In no case will the CSS warranty exceed the standard published warranty of its customer in terms of time and/or distance. In all events, the CSS warranty will expire thirty (30) months after the date of manufacture as stamped on the Product. In the case of hydraulic equipment, operation with unapproved fluid or temperatures voids this warranty.
- VI. EXCLUSION OF ALL OTHER REMEDIES AND LIMITATION OF LIABILITY:** Customer's sole and exclusive remedy under the foregoing warranty shall be for the repair, replacement or issuance of credit with respect to a defective product, as set forth and described above. Other provisions hereof notwithstanding, CSS shall not be liable to Customer, or any successor in interest, beneficiary or assignee of Customer, based upon any claim against CSS, whether in contract, warranty, negligence, strict liability, indemnity or otherwise, for any special, consequential, incidental or other damages relating in any way to the design, manufacture, sale, installation or other use of any product purchased from CSS.
- VII. EXCLUSION OF ALL OTHER WARRANTIES: THE FOREGOING WARRANTY IS THE EXCLUSIVE WARRANTY BY CSS AND IS IN LIEU OF AND EXCLUDES ALL OTHER WARRANTIES AND REPRESENTATIONS, WHETHER ORAL, WRITTEN, EXPRESSED, IMPLIED OR STATUTORY, INCLUDING BUT NOT LIMITED TO ANY WARRANTY OF MERCHANTABILITY OR FITNESS FOR A PARTICULAR PURPOSE.**



Fire and Rescue Apparatus

Lifetime Fifty (50) Year Structural Integrity Custom Chassis Frame Limited Warranty

1. LIMITED WARRANTY

Subject to the limitations and exclusions set forth below, Pierce Manufacturing provides the following warranty to the Buyer:

Coverage:	Custom chassis frame rail manufactured by Pierce shall be free from defects in material and workmanship
Warranty Begins:	The date of the original purchase invoice (issued when the product ships from the factory).
Warranty Period Ends After:	Fifty (50) Years (Expected Life of Apparatus)
Conditions and Exclusions: See Also Paragraphs 2 thru 4	This warranty does not apply to damage caused by corrosion.

This limited warranty shall apply only if the product is properly maintained in accordance with Pierce's maintenance instructions and manuals and is used in service which is normal to the particular model. Normal service means service which does not subject the product to stresses or impacts greater than normally result from careful use. If the Buyer discovers a defect or nonconformity, it must notify Pierce in writing within thirty (30) days after the date of discovery, but in any event prior to the expiration of the warranty period. THIS LIMITED WARRANTY MAY NOT BE ASSIGNED OR OTHERWISE TRANSFERRED BY THE BUYER TO ANY SUBSEQUENT USER OR PURCHASER OR TO ANY OTHER PERSON OR ENTITY.

Notwithstanding anything to the contrary herein, Pierce makes no warranty whatsoever as to:

(a) any integral parts, components, attachments or trade accessories of or to the product that are not manufactured by Pierce, including but not limited to engines, transmissions, drivelines, axles, water pumps and generators; with respect to all such parts, components, attachments and accessories, Pierce shall assign to Buyer the applicable warranties, if any, made by the respective manufacturers thereof;

(b) any vehicle, chassis, or component, part, attachment or accessory damaged by misuse, neglect, fire, exposure to severe environmental or chemical conditions, acidic environment, improper maintenance, accident, crash, or force majeure such as natural disaster, lightning, earthquake, windstorm, hail, flood, war or riot;

(c) any vehicle, chassis or component, part, attachment or accessory that has been repaired, altered or assembled in any way by any person or entity other than Pierce which, in the sole judgment of Pierce, adversely affects the performance, stability or purpose for which it was manufactured; or

(d) products or parts which may in the ordinary course wear out and have to be replaced during the warranty period, including, but not limited to, tires, fluids, gaskets and light bulbs. Pierce assumes no responsibility for the assembly of its parts or subassemblies into finishing products or vehicles unless the assembly is performed by Pierce.

The original purchaser may void this warranty in part or in its entirety if the product is repaired or replaced (a) without prior written approval of the Pierce Customer Service Department; or (b) at a facility which has not been approved by Pierce as to technical capability. Any repairs, modifications, alterations or aftermarket parts added after manufacture without the authorization of Pierce may void this warranty.

2. DISCLAIMERS OF WARRANTIES

THE WARRANTY SET FORTH IN PARAGRAPH 1 IS THE SOLE AND EXCLUSIVE WARRANTY GIVEN BY PIERCE. PIERCE HEREBY DISCLAIMS AND EXCLUDES ALL OTHER WARRANTIES, WHETHER EXPRESS, IMPLIED OR STATUTORY, INCLUDING WITHOUT LIMITATION ANY WARRANTY OF MERCHANTABILITY, ANY WARRANTY OF FITNESS FOR A PARTICULAR PURPOSE, AND ANY WARRANTIES ARISING FROM COURSE OF DEALING OR USAGE OF TRADE.

3. BUYER'S EXCLUSIVE REMEDY

If the product fails to conform to the warranty set forth in paragraph 1 during the warranty period, and such nonconformity is not due to misuse, neglect, accident or improper maintenance, Buyer must notify Pierce within the time period specified in paragraph 1, and shall make the product available for inspection by Pierce or its designated agent. At the request of Pierce, any allegedly defective product shall be returned to Pierce by Buyer for examination and/or repair. Buyer shall be responsible for the cost of such transportation, and for risk of loss of or damage to the product during transportation. Within a reasonable time, Pierce shall repair or replace (at Pierce's option and expense) any nonconforming or defective parts. Repair or replacement shall be made only by a facility approved in advance in writing by Pierce. THIS REMEDY SHALL BE THE EXCLUSIVE AND SOLE REMEDY FOR ANY BREACH OF WARRANTY.

4. EXCLUSION OF CONSEQUENTIAL AND INCIDENTAL DAMAGES

Notwithstanding anything to the contrary herein or in any agreement between Pierce and Buyer, IN NO EVENT SHALL PIERCE BE LIABLE FOR ANY CONSEQUENTIAL, INCIDENTAL, SPECIAL, INDIRECT, OR PUNITIVE DAMAGES WHATSOEVER, WHETHER ARISING OUT OF BREACH OF CONTRACT, WARRANTY, TORT (INCLUDING NEGLIGENCE AND STRICT LIABILITY) OR OTHER THEORY OF LAW OR EQUITY, WITH RESPECT TO VEHICLES OR OTHER PRODUCTS SOLD BY PIERCE, OR THEIR OPERATION OR FAILURE TO OPERATE, OR ANY DEFECTS THEREIN, OR ANY UNDERTAKINGS, ACTS OR OMISSIONS RELATED THERETO, REGARDLESS OF WHETHER PIERCE HAS BEEN INFORMED OF THE POSSIBILITY OF ANY SUCH DAMAGES. Without limiting the generality of the foregoing, Pierce specifically disclaims any liability for property or personal injury damages, penalties, damages for lost profits or revenues, loss of vehicles or products or any associated equipment, cost of substitute vehicles or products, down-time, delay damages, any other types of economic loss, or for any claims by any third party for any such damages.

Note: Any Surety Bond, if a part of the sale of the vehicle as to which this limited warranty is provided, applies only to this Pierce Basic One Year Limited Warranty for such vehicle, and not to other warranties made by Pierce in a separate document (if any) or to the warranties (if any) made by any manufacturer (other than Pierce) of any part, component, attachment or accessory that is incorporated into or attached to the vehicle.

MARMON-HERRINGTON
PARTS AND COMPONENTS WARRANTY

Effective: January 1, 2011

Warranty Description

This is to certify that we, Marmon-Herrington Company will warrant each new chassis, assembly or component purchased by the buyer from Marmon-Herrington or an Authorized Marmon-Herrington dealer, and installed as original equipment against defects in material and workmanship under approved application use and service. Marmon-Herrington's components are warranted for a period of 12 months or 12,000 miles from the "in-service date" specified on the *completed and returned* "Warranty Registration Card." Under no circumstances will warranty consideration be available after 18 months of original invoice date.

This warranty does not cover normal wear and tear, or a component that fails, malfunctions or is damaged as a result of: **(1)** improper installation, adjustment, repair or modification, usage, or application differing from that which was originally approved by Marmon-Herrington; **(2)** accident, natural disaster, acts of god, climate, combat damage; **(3)** abuse or improper use, including loading beyond specified maximum vehicle or axle weight or adjusted engine power settings that exceed axle or transfer case input capacity; **(4)** improper or insufficient maintenance, to include use unapproved lubricant types or levels, or failure to follow published maintenance schedules; **(5)** costs incurred gaining access to components due to chassis or body design, or vehicle location.

This warranty **does not** include travel time, travel expenses or towing charges. This warranty does not cover any part or component not sold by Marmon-Herrington.

This warranty provides for parts and labor at Marmon-Herrington's sole discretion. Marmon-Herrington reserves the right to provide replacement parts directly to the repair facility. Labor hours are limited to the Marmon-Herrington Standard Repair Time Table.

This warranty is in lieu of all other warranties expressed or implied, and of all other obligations or liabilities incurred by Marmon-Herrington. Marmon-Herrington does not authorize any other entity to assume or express any liability in conjunction with the purchase or sale of Marmon-Herrington parts or components.

Repair Reporting

Owner/Operator must contact Marmon-Herrington Customer Service prior to performing any repairs to receive Repair Authorization to be eligible for warranty reimbursement. This authorization does not guarantee reimbursement, but acknowledges that the vehicle or component is within the warranty period, and that a claim has been activated. It is the responsibility of the owner/operator to ensure that the repair facility acknowledges and complies with the guidelines of this policy.

At the time of Repair Authorization request, the following must be provided:

- a) Marmon-Herrington Sales Order Number
- b) Vehicle Identification Number
- c) Vehicle In-Service Date
- d) Current mileage

If a Warranty Registration Card is not on file, this must be completed before Repair Authorization can be issued.

Repair Procedure and Claim Filing

Repair facilities will submit a written estimate of costs after it is determined that a warrantable condition exists.

Estimates must contain the following information:

- (a) List of all necessary parts required.
- (b) Labor costs for disassembly, inspection and diagnosis.
- (c) Current labor rate.

Repair Orders and Invoices

Repair orders, claims and/or invoices must contain the following:

- (a) Authorization number
- (b) Customer's name, address, and contact information
- (c) Vehicle Identification Number
- (d) Component Model and Serial Number

Note: Miscellaneous items such as shop supplies, environmental charges, or "default administrative costs" will not be paid. All materials and supplies must be itemized and clearly defined. Any sublet repairs must have an accompanying invoice from the original vendor.

Marmon-Herrington reserves the right to withhold payment until failed parts are returned for analysis. A Return Authorization will be issued at the time replacement parts are shipped.

While Marmon-Herrington operates a full-service parts department, replacement parts for warranty repairs must be obtained through Marmon-Herrington Customer Service to be eligible for warranty reimbursement. Claims that include parts purchased through other sources will be subject to cost adjustment.

Service Parts are warranted for a period of ninety (90) days or five thousand (5,000) miles, whichever occurs first. All other regular warranty conditions apply.

Remember to visit our website for parts and repair manuals, detailed component information and available services.

Marmon-Herrington Company
13001 Magisterial Drive
Louisville, KY 40223
800.227.0727 General
502.379.6699 Customer Service
marmon-herrington.com





Dana Holding Corporation
Commercial Vehicle Products Group
Grace Lake Corporate Center
1 Village Center Drive
Van Buren Township, Michigan 48111
www.dana.com

New for 2011!

Dana Holding Corporation is pleased to announce a change in our standard warranty for fire/rescue vehicles. All steer and drive axles will now come with a 5 year / 100,000 mile warranty. For further information, please go to www.roadranger.com.

Dana Holding Corporation is working with chassis manufactures to supply a 24K front steer beam with a 5 ¼' drop. We have listened to your requests for a slightly higher GAWR for single axle aerials. Not all fire stations can accommodate a long wheel base application. This allows manufactures to meet the limited length requirements for smaller fire houses. Please submit your requests through our website. Please indicate on the application your need for 24K GAWR.

Finally, our drive axles will accommodate simultaneous auxiliary braking. Dana axles are built tough and were design with Telma retarders in mind. Submit your application for single or tandem designation.

Dana Holding Corporation will work with you to provide the best drive train solution with the best warranty in the fire/rescue industry. For additional information please contact:

Alan Manzon
Account Manager - Specialty Markets
Dana Holding Corporation
One Village Center Dr.
Van Buren Twp., MI 48111-5711

Phone: (734)629-1141

Cell: (269)312-3220

Alan.manzon@dana.com



Fire and Rescue Apparatus

Three (3) Year Material and Workmanship Meritor Wabco ABS Brake System Limited Warranty

1. LIMITED WARRANTY

Subject to the limitations and exclusions set forth below, Pierce Manufacturing provides the following warranty to the Buyer:

Coverage:	The Meritor Wabco ABS brake system shall be covered by Meritor Wabco as indicated in the attached Meritor Wabco warranty coverage description
Warranty Begins:	The date of the original purchase invoice (issued when the product ships from the factory).
Warranty Period Ends After:	Three (3) Year
Conditions and Exclusions: See Also Paragraphs 2 thru 4	The exclusions listed in the attached Meritor Wabco warranty description shall apply.

Notwithstanding anything to the contrary herein, Pierce makes no warranty whatsoever as to:

(a) any integral parts, components, attachments or trade accessories of or to the product that are not manufactured by Pierce, including but not limited to engines, transmissions, drivelines, axles, water pumps and generators; with respect to all such parts, components, attachments and accessories, Pierce shall assign to Buyer the applicable warranties, if any, made by the respective manufacturers thereof;

(b) any vehicle, chassis, or component, part, attachment or accessory damaged by misuse, neglect, fire, exposure to severe environmental or chemical conditions, acidic environment, improper maintenance, accident, crash, or force majeure such as natural disaster, lightning, earthquake, windstorm, hail, flood, war or riot;

(c) any vehicle, chassis or component, part, attachment or accessory that has been repaired, altered or assembled in any way by any person or entity other than Pierce which, in the sole judgment of Pierce, adversely affects the performance, stability or purpose for which it was manufactured; or

(d) products or parts which may in the ordinary course wear out and have to be replaced during the warranty period, including, but not limited to, tires, fluids, gaskets and light bulbs. Pierce assumes no responsibility for the assembly of its parts or subassemblies into finishing products or vehicles unless the assembly is performed by Pierce.

The original purchaser may void this warranty in part or in its entirety if the product is repaired or replaced (a) without prior written approval of the Pierce Customer Service Department; or (b) at a facility which has not been approved by Pierce as to technical capability. Any repairs, modifications, alterations or aftermarket parts added after manufacture without the authorization of Pierce may void this warranty.

2. DISCLAIMERS OF WARRANTIES

THE WARRANTY SET FORTH IN PARAGRAPH 1 IS THE SOLE AND EXCLUSIVE WARRANTY GIVEN BY PIERCE. PIERCE HEREBY DISCLAIMS AND EXCLUDES ALL OTHER WARRANTIES, WHETHER EXPRESS, IMPLIED OR STATUTORY, INCLUDING WITHOUT LIMITATION ANY WARRANTY OF MERCHANTABILITY, ANY WARRANTY OF FITNESS FOR A PARTICULAR PURPOSE, AND ANY WARRANTIES ARISING FROM COURSE OF DEALING OR USAGE OF TRADE.

3. BUYER'S EXCLUSIVE REMEDY.

If the product fails to conform to the warranty set forth in paragraph 1 during the warranty period, and such nonconformity is not due to misuse, neglect, accident or improper maintenance, Buyer must notify Pierce within the time period specified in paragraph 1, and shall make the product available for inspection by Pierce or its designated agent. At the request of Pierce, any allegedly defective product shall be returned to Pierce by Buyer for examination and/or repair. Buyer shall be responsible for the cost of such transportation, and for risk of loss of or damage to the product during transportation. Within a reasonable time, Pierce shall repair or replace (at Pierce's option and expense) any nonconforming or defective parts. Repair or replacement shall be made only by a facility approved in advance in writing by Pierce. THIS REMEDY SHALL BE THE EXCLUSIVE AND SOLE REMEDY FOR ANY BREACH OF WARRANTY.

4. EXCLUSION OF CONSEQUENTIAL AND INCIDENTAL DAMAGES.

Notwithstanding anything to the contrary herein or in any agreement between Pierce and Buyer, IN NO EVENT SHALL PIERCE BE LIABLE FOR ANY CONSEQUENTIAL, INCIDENTAL, SPECIAL, INDIRECT, OR PUNITIVE DAMAGES WHATSOEVER, WHETHER ARISING OUT OF BREACH OF CONTRACT, WARRANTY, TORT (INCLUDING NEGLIGENCE AND STRICT LIABILITY) OR OTHER THEORY OF LAW OR EQUITY, WITH RESPECT TO VEHICLES OR OTHER PRODUCTS SOLD BY PIERCE, OR THEIR OPERATION OR FAILURE TO OPERATE, OR ANY DEFECTS THEREIN, OR ANY UNDERTAKINGS, ACTS OR OMISSIONS RELATED THERETO, REGARDLESS OF WHETHER PIERCE HAS BEEN INFORMED OF THE POSSIBILITY OF ANY SUCH DAMAGES. Without limiting the generality of the foregoing, Pierce specifically disclaims any liability for property or personal injury damages, penalties, damages for lost profits or revenues, loss of vehicles or products or any associated equipment, cost of substitute vehicles or products, down-time, delay damages, any other types of economic loss, or for any claims by any third party for any such damages.

Note: Any Surety Bond, if a part of the sale of the vehicle as to which this limited warranty is provided, applies only to this Pierce Basic One Year Limited Warranty for such vehicle, and not to other warranties made by Pierce in a separate document (if any) or to the warranties (if any) made by any manufacturer (other than Pierce) of any part, component, attachment or accessory that is incorporated into or attached to the vehicle.

This limited warranty shall apply only if the product is properly maintained in accordance with Pierce's maintenance instructions and manuals and is used in service which is normal to the particular model. Normal service means service which does not subject the product to stresses or impacts greater than normally result from careful use. If the Buyer discovers a defect or nonconformity, it must notify Pierce in writing within thirty (30) days after the date of discovery, but in any event prior to the expiration of the warranty period. THIS LIMITED WARRANTY MAY NOT BE ASSIGNED OR OTHERWISE TRANSFERRED BY THE BUYER TO ANY SUBSEQUENT USER OR PURCHASER OR TO ANY OTHER PERSON OR ENTITY.

WARRANTY

MODEL YEAR 2021 VEHICLES



Warranty coverage is essential to protecting your investment. But understanding the full details of your coverage can be challenging. This straightforward approach allows you, our valued customer, to better understand how your specific vehicle applications will be covered in your region. Our component warranty coverage is provided according to vocation/usage categories listed below.

- Linehaul covers high mileage operation (over 60,000 miles/year) on well-maintained major highways of concrete or asphalt construction.
- General Service covers moderate mileage operations (less than 60,000 miles/year) on well-maintained public roads (less than 10 percent off-road) typically with less than three (3) stops per mile.
- Heavy Service (Vocational) covers vehicles with more than 10 percent off-road OR moderate to frequent starts/stops typically with more than three (3) stops per mile.
- Off-Highway Service covers lower mileage operations. Vehicles are not typically licensed for highway use.

How to Read Warranty Coverage (Example)

Number of Years	Mileage (in thousands) Unl=Unlimited	P=Parts Only P&L=Parts & Labor
3	300	P

- The standard aftermarket warranty for WABCO products - including WABCO Original parts, WABCO Reman Solutions, ProVia quality aftermarket parts and WABCO retrofit solutions - is one year, parts only from in-service date when purchased from ZF distributor networks or its affiliates and/or subsidiaries.

WABCO

WARRANTY - MODEL YEAR 2021 VEHICLES

LINEHAUL/GENERAL SERVICE WARRANTY INFORMATION

LINEHAUL/GENERAL SERVICE VEHICLES

- Aerial Ladder Truck
- Aerial Platform
- Ambulance
- Auto Hauler
- Beverage Truck
- Bulk Hauler
- Chip Hauler (Truck)
- Cross Country Coach
- Doubles
- Flatbed
- Front Engine Commercial Chassis
- Front Engine Integral Coach
- General Freight
- Grain Hauler
- Intercity Coach
- Intermodal Chassis
- Livestock Hauler
- Meat Packer
- Moving Van
- Municipal Truck
- Pipe Hauler
- Platform Auto Hauler
- Pumper
- Rear Engine Integral Coach
- Recreational Vehicles
- Refrigerated Freight
- School Bus
- Stake Truck
- Tanker
- Tanker Truck
- Triples
- Tour Bus
- Wrecker

LINEHAUL TYPICALLY IS

- High mileage operation (over 60,000 miles/year)
- Well maintained major highways of concrete or asphalt construction

GENERAL SERVICE TYPICALLY IS

- Moderate mileage operations (less than 60,000 miles/year)
- Well maintained public roads (less than 10% off-road)
- Less than three (3) stops per mile

WABCO Components ¹	
Air Management	
Air Brake Valves	1/100/P&L
Trailer Lift Axle Control Valve	
Trailer Control Line Filter ³	
Air Compressors (ALL) ²	2/200/P&L
Air Dryers (ALL)	3/300/P&L
Aerodynamics	
OptiFlow® TrailerSkirt	2/UnU/P
OptiFlow® Trailer Tail and AutoTail	2/UnI/P
Braking Systems	
ABS (Anti-Lock Braking System) Air	3/300/P&L
ABS (Anti-Lock Braking System) Hydraulic	
Electronic Braking System (EBS)	
Electronic Stability Control (ESC)	
Roll Stability Control (RSS)	
Trailer Roll Stability Support (RSS)	
Trailer ABS (Anti-Lock Braking System) ³	
Driveline Suspension Control	
Clutch Controls	2/200/P&L
Leveling Valves	1/100/P&L
OptiRide® Automated Manual Transmission (AMT)	
OptiRide® Electronically Controlled Air Suspension (ECAS)	3/300/P&L

WABCO Components ¹ (cont.)	
Safety	
OnGuardACTIVE®	3/300/P&L
OnLane®	
OnLaneALERT®	
OnSide®	
Trailer SafeStart™	
Trailer TailGUARD™	
Telematics	
TrailerCAST™ Telematics Device	3/300/P&L
Wheel End Solutions	
EasyFit™ Slack Adjuster	6/600/P
MAXXUS™ Truck Air Disc Brake	5/500/P&L
IVTM - Wheel Module	6/P
IVTM - All Other Products	2/P
Pan 17 and 19 Air Disc Brake	2/UnI/P and 1/UnI/L
Pan 22 Air Disc Brake	5/500/P and 1/L
TRISTOP™ D Actuator w/ IBV or IRB	6/600/P
TRISTOP™ D Actuator	3/300/P
UNISTOP™ Actuator	2/200/P
Trailer MAXX22T™ Air Disc Brake	5/500/P and 1/L

¹ ZF and WABCO branded components. ² WABCO compressors installed on Cummins, Mercedes, and DDC engines are not warranted or serviced by ZF. Please contact your respective dealer/distributor of those engines for warranty and servicing. ³ An extended warranty of 4/400/P will apply when a WABCO Trailer Control Line Filter is used in combination with a WABCO Trailer ABS valve.

HEAVY SERVICE (VOCATIONAL) WARRANTY INFORMATION

HEAVY SERVICE VEHICLES

- Airport Rescue Fire (ARF)
- Airport Shuttle
- Asphalt Truck
- Block Truck
- Bottom Dump Trailer Combination
- Cementing Vehicle
- City Bus
- Commercial Pick-Up
- Concrete Pumper
- Construction Material Hauler
- Crash Fire Rescue (CFR)
- Mixer
- Demolition
- Drill Rig
- Dump
- Emergency Service
- Equipment Hauling
- Flatbed Trailer Hauler
- Flatbed Truck
- Fracturing Truck
- Front Loader
- Geophysical Exploration
- Hopper Trailer Combinations
- Landscaping Truck
- Liquid Waste Hauler
- Log Hauling
- Lowboy
- Michigan Special Gravel Trains
- Michigan Special Log Hauler
- Michigan Special Steel Hauler
- Michigan Special Waste Vehicle
- Municipal Dump
- Newspaper Delivery
- Package Delivery
- Pick-up and Delivery
- Rapid Intervention Vehicle (RIV)
- Rear Loader
- Recycling Truck
- Residential Pick-Up/Waste
- Rigging Truck
- Roll-Off
- Scrap Truck
- Semi-End Dump
- Sewer/Septic Vacuum
- Shuttle Bus
- Side Loader
- Snowplow/Snowblower
- Steel Hauling
- Tanker
- Tank Truck
- Tractors with Pole Trailers
- Tractor/Trailer with Jeeps
- Transfer Dump
- Transfer Vehicle
- Transit Bus
- Trolley
- Utility Truck
- Winch Truck

HEAVY SERVICE TYPICALLY IS

- On/Off road vocations (10% or more off-road) OR
- Moderate to frequent starts/stops typically more than three (3) stops per mile



WABCO Components ¹	
Air Management	
Air Brake Valves	1/100/P&L
Air Compressors (ALL) ²	
Air Dryers (ALL)	
Trailer Control Line Filter ³	
Braking Systems	
ABS (Anti-Lock Braking System) Air	3/300/P&L
ABS (Anti-Lock Braking System) Hydraulic	2/200/P&L
Electronic Braking System (EBS)	3/300/P&L
Electronic Stability Control (ESC)	
Trailer ABS Valve ³	
Roll Stability Control (RSS)	
Trailer Roll Stability Support (RSS)	
Driveline Suspension Control	
OptiRide [®] Electronically Controlled Air Suspension (ECAS)	2/200/P&L
Leveling Valves	1/100/P&L
Clutch Controls	2/200/P&L
Safety	
OnGuardACTIVE [®]	3/300/P&L
OnLane [®]	
OnLaneALERT [®]	
OnSide [®]	
Trailer SafeStart [™]	
Trailer TailGUARD [™]	
Telematics	
TrailerCAST [™] Telematics Device	3/300/P&L
Wheel End Solutions	
EasyFit [™] Slack Adjuster	2/200/P
MAXXUS [™] Air Disc Brake	1/Unl/P&L
IVTM - Wheel Module	6/P
IVTM - All Other Products	2/P
Pan 22, 19 and 17 Air Disc Brake	1/Unl/P&L
Trailer MAXX22T [™]	1/Unl/P&L
TRISTOP [™] D Actuator w/ IBV	3/Unl/P
TRISTOP [™] D Actuator	2/200/P
UNISTOP [™] Actuator	1/100/P

¹ ZF and WABCO branded components. ² WABCO compressors installed on Cummins, Mercedes, and DDC engines are not warranted or serviced by ZF. Please contact your respective dealer/distributor of those engines for warranty and servicing. ³ An extended warranty of 4/400/P will apply when a WABCO Trailer Control Line Filter is used in combination with a WABCO Trailer ABS valve.

WARRANTY - MODEL YEAR 2021 VEHICLES

INDUSTRIAL/OFF-HIGHWAY SERVICE WARRANTY INFORMATION

INDUSTRIAL AND OFF-HIGHWAY SERVICE TYPICALLY IS

- Low mileage operation³
- Vehicles are not typically licensed for highway use

Market	Common Application Types
Agriculture	Fertilizer Spreader, Tractor, Heavy Duty Ag Trailers, Harvester, Sprayer, Skid Loader, Silage Bagger, Slurry Wagons, Grain Cart
Airport Support	Pushback Tractor, Towing Tugs, Aircraft Tow Tractor, Refueling Trucks, Food Service Trucks, Baggage Tractors, De-Icing Equipment, Runway Clearing Equipment
Construction	All-Terrain Crane, Rough Terrain Crane, Excavator, Compactor, Wheel Loader, Road Roller, Motor Grader, Articulated Dump Truck, Rubber Tire Road Roller, Backhoe Loaders, Haul Trucks, Scraper Rough Terrain Forklifts, Trenchers, Drills
Forestry	Logging Forwarder, Kidder, Loaders, Yard Forklifts, Harvesters Fellers
Material Handling	Port Tractor, Rail Yard Spotter, Stevedoring Tractor, Trailer Spotter, Yard Jockey, Scissor Lift, Straddle Carrier, Manlift, Forklift, Boom Lift Telehandlers, Aerial Work Platforms
Mining	Specialized Mining, Excavator, Haul Truck, Underground Loader, Service Trucks, Wheel Loaders, Scrapers, Load Haul Dumps, Personnel Transports, Bolters, Scalars
Municipal	Street Sweeper, Utility Tractor, Utility Trucks, Tree Trimmers, Dump Trucks, Tow Trucks, Flat Bed Trucks, Winch Applications
Oil & Gas	Fracturing Trailer, Injector Heads, Top Drives, Jack/Lift Boats, Wireline Trucks, Load-On / Load-Off
Rail	Railcar Mover, Track Layers, Grinders, Platform Crane, Locomotive Railcars, Ballast Equipment, Winch Applications



WABCO Components ¹	
Air Management	
Air Brake Valves	2/Unl/P
Air Compressors (ALL) ²	
Air Dryers (ALL)	
Brake Actuation	
Air/Hydraulic Actuators	2/Unl/P
Master Cylinders	
Remote Actuators	
Slave and Wheel Cylinders	
Two Fluid Actuators	
Brake Locks	
Brake Locks (ALL)	2/Unl/P
Electric Brake Locks	
Lever Locks	
Braking Systems	
ABS (Anti-Lock Braking System) Air	1/100/P&L
ABS (Anti-Lock Braking System) Hydraulic	
Driveline Suspension Control	
Clutch Controls	1/100/P&L
Leveling Valves	
Electrohydraulics & Controls	
Electronic Pedals	2/Unl/P
Electrohydraulic Brake Valves (EBV)	
Pressure Switches	
Hydraulic Braking Solutions	
Accumulator Charging Valves	2/Unl/P
Hydraulic Throttle Controls and Switches	
Modulating Brake Valves	
Wheel End Solutions	
EasyFit™ Slack Adjuster	2/200/P
Caliper Disc Brakes	2/Unl/P
MAXXUS™ Air Disc Brake	1/Unl/P&L
Multiple Disc Brakes	2/Unl/P
IVTM - Wheel Module	6/P
IVTM - All Other Products	2/P
Pan 22, 19 and 17 Air Disc Brake	1/Unl/P&L
TRISTOP™ D Actuator w/ IBV	3/Unl/P
TRISTOP™ D Actuator	2/200/P
UNISTOP™ Actuator	1/100/P

¹ ZF and WABCO branded components. ² WABCO compressors installed on Cummins, Mercedes, and DDC engines are not warranted or serviced by ZF. Please contact your respective dealer/distributor of those engines for warranty and servicing. ³ Equivalent hours of service limit: 2,000 hours for all components.

TERMS AND CONDITIONS

COVERAGE EXCLUSIONS

PRODUCT DESCRIPTION

ALL PRODUCTS

This Warranty shall not apply to the following, but not limited to: (1) damage to the product or its component parts caused by incorrect use, installation, maintenance or repair, including without limitation (a) improper fit of mating components or brackets, damaged threads, cut, broken, chafed, pinched or otherwise damaged wiring (sensors, harnesses and connectors), (b) sensors damaged during removal when seized in block, or associated with sensor adjustments/ alignments, and (c) damage resulting from the use or installation of non-genuine WABCO components or materials; (2) damage to the product, its component parts, or diminished product or component part performance due to incorrect operation, deviation from approved conditions or misapplication; (3) any unauthorized disassembly of the product or its component parts including without limitation (a) obliterated, defaced or missing WABCO or WABCO name plate, serial numbers or label identifying the device as a ZF product or WABCO component, (b) changes to sealed adjusting screws, and (c) opening or attempted repair of non-serviceable components; (4) malfunction of the component due to internal contamination of the vehicle system including without limitation (a) water and other contamination damage that is due to the use of a non-genuine air dryer cartridge or (b) valve failures due to contamination in air system, (5) complaints associated with noise, (6) damage resulting from corrosion (including oxidation of electrical devices and connections).

AIR DRYERS

Mounting brackets (see vehicle OEM). Desiccant cartridge housing only.

AIR SYSTEM COMPONENTS

Normal wear items; Gladhand seals, dash valve knobs, valve actuation handles, treadles, pedals.

ABS, ELECTRONIC STABILITY CONTROL (ESC), ROLL STABILITY CONTROL (RSC), OPTIRIDE®, ONGUARD® AND ONLANE®, COLLECTIVELY “ELECTRONICS”

Failure of electronic components due to overvoltage condition, improper grounding, electrostatic discharge (ESD), improper shielding, electromagnetic interference (EMI), or other wiring or installation issues. Malfunctions and failure codes caused by other electronic subsystem failures (data bus, engine, transmission, dashboard, etc.)

HYDRAULIC COMPONENTS

For certain components, brake fluid DOT3 or DOT4 is used as the operating medium. Use of any other fluid will void all warranties associated with that component. For hydraulic braking applications the brake fluid is considered a maintenance item. Maintenance intervals are listed in TB-1367.

COVERAGE LIMITATIONS

PRODUCT DESCRIPTION

ALL PRODUCTS

Any claim beyond 60 days from date of repair will not be accepted or honored under this warranty program.

Products purchased on an incomplete vehicle (glider) are limited to one year, 1/Unl/P.

For vehicles that operate full- or part-time outside of the United States and Canada, a 1-Year/Unlimited Miles parts only (1/Unl/P) will apply.

TOOLBOX PLUS™ DIAGNOSTIC SOFTWARE

Proper diagnostics of WABCO Electronics may require the latest version of TOOLBOX PLUS™. Additional labor due to use of an outdated version of TOOLBOX™ software and/or the time to purchase or install the latest version of TOOLBOX PLUS™ are not covered under product warranty.

WARRANTY - MODEL YEAR 2021 VEHICLES

TERMS AND CONDITIONS

(1) What is Covered by this Commercial Warranty?

ZF CV Systems North America LLC and its North American subsidiaries and affiliates (ZF) warrant to the owner ("Owner") that the components listed in this publication, which have been installed by an Original Equipment Manufacturer ("OEM") as original equipment will be free from defects in material and workmanship. This warranty coverage begins from the original in-service date to the limits provided and runs concurrently with any warranties provided by OEMs and/or any distribution agreements and/or any service contracts that cover the components listed in this publication, if any. If the components listed in this publication are covered by an OEM warranty and/or service contract, then the OEM's warranty and/or service contract shall supersede ZF's warranty and Owner shall comply with all OEM's warranty and/or service contract requirements for claims under such OEM's warranty and/or service contract until those agreements expire. Once those agreements expire and provided the ZF warranty has not expired under the terms stated above, the ZF warranty will be in effect until its expiration date.

Warranty coverage ends at the expiration of the applicable time period from the date of vehicle purchase by the first Owner, or, the applicable mileage limitation, whichever occurs first. Duration of coverage varies by component and vocation as detailed previously in this publication. Some components are warranted for parts only and the Owner must pay any labor costs associated with the repair or replacement of the component. Other components are warranted for both parts and reasonable labor to repair or replace the subject component. Additional diagnostic time due to use of an outdated version of TOOLBOX™, time to purchase or install latest version of TOOLBOX™ are the responsibility of the authorized ZF distributor networks and are not covered under product warranty. Components installed as replacements under this warranty are warranted only for the remainder of the original period of time or mileage under the original warranty.

(2) Designation of Vocational Use Required. To obtain warranty coverage, each Owner must notify ZF through the OEM new truck and/or trailer dealer of the intended vocational use of the vehicle into which the WABCO components have been incorporated prior to the vehicle in-service date. This notification may be accomplished by registering the vehicle through your OEM new truck and/or trailer dealer or with ZF directly. Failure to notify ZF of (I) the intended vocational use of the vehicle or (II) a change in vocational use from that which was originally designated, will result in the application of a one year, unlimited mileage, parts only warranty (1/Unl/P) from the initial in-service date. A second Owner and each subsequent Owner must also notify ZF as to the intended vocational use of the vehicle. This notification can be sent directly to ZF or through

the OEM new truck and/or trailer dealer. The duration and mileage coverage of this warranty cannot exceed the coverage extended to the first Owner after his or her initial designation of vocational use. Coverage under ZF's warranty requires that the application of products be properly approved pursuant to OEM and ZF, approvals.

- (3) What is the Cost of this Warranty? There is no charge to the Owner for this warranty.
- (4) What is not Covered by this Warranty? In addition to the items listed on "Coverage Exclusions," this warranty does not cover normal wear and tear, or service items; nor does it cover a component that fails, malfunctions or is damaged as a result of (a) improper handling, storage, installation, adjustment, repair or modification including the use of unauthorized attachments or changes or modification in the vehicle's configuration, usage, or vocation from that which was originally approved by ZF, (b) accident, fire or other casualty, natural disaster, road debris, negligence, misuse, abuse, or improper use (including loading beyond the specified maximum vehicle weight or altering engine power settings to exceed the brake system capacity), or (c) improper or insufficient maintenance (including deviation from maintenance intervals, approved lubricants, or lube levels). This warranty does not cover any component or part that is not sold by ZF.
- (5) To obtain service. If the owner discovers within the applicable coverage period a defect in material or workmanship, the Owner must promptly give notice to either ZF or the dealer from which the vehicle was purchased. To obtain service, the vehicle must be taken to any participating OEM dealer or ZF distributor networks' servicer. The dealer or ZF authorized servicer will inspect the vehicle and contact ZF for an evaluation of the claim. When authorized by ZF, the dealer or ZF authorized servicer will repair or replace during the term of this warranty any defective WABCO component covered by this warranty.
- (6) Disclaimer of Warranty and Limitation of remedies. TO THE MAXIMUM EXTENT PERMITTED BY LAW, THE LIMITED WARRANTY SET FORTH HEREIN IS EXCLUSIVE AND IS IN LIEU OF ALL OTHER WARRANTIES, EXPRESS OR IMPLIED, ARISING BY OPERATION OF LAW OR OTHERWISE, INCLUDING, WITHOUT LIMITATION, ANY IMPLIED WARRANTY OF MERCHANTABILITY OR FITNESS FOR A PARTICULAR PURPOSE AND/OR WARRANTY FOR HIDDEN OR LATENT DEFECTS, AND IN NO EVENT WILL ZF OR ANY OF ITS AFFILIATES BE LIABLE FOR DIRECT, INDIRECT, INCIDENTAL, PROGRESSIVE, SPECIAL, OR CONSEQUENTIAL DAMAGES OF ANY KIND.

- (7) Legal action. Any legal action or claim arising from or related to this Warranty, in contract or otherwise, must be commenced within one year from the accrual of that cause of action, or be barred forever. Any dispute arising in connection with this agreement shall be governed by and construed according to the laws of the State of Michigan and be brought, heard and determined exclusively in either the Circuit Court for the County of Oakland, State of Michigan or the United States District Court for the Eastern District of Michigan. The parties stipulate that the referenced venues are convenient.
- (8) Remedy. The exclusive remedy under this warranty shall be the repair or replacement of the defective component at ZF's option. ZF reserves the right to require that all applicable covered components are available and/or returned to ZF for review and evaluation. THE MAXIMUM LIABILITY, IF ANY, OF ZF FOR ALL DAMAGES, INCLUDING WITHOUT LIMITATION CONTRACT DAMAGES, BREACH OF WARRANTY, NEGLIGENCE, STRICT LIABILITY, OR OTHER TORT, IS LIMITED TO AN AMOUNT NOT TO EXCEED THE PURCHASE PRICE OF THE PRODUCT and where indicated in the product and application warranty information above, the inclusion of labor is limited to the standard repair time. THE PARTIES ACKNOWLEDGE AND AGREE THAT THE LIMITATION OF DAMAGES PROVISION SET FORTH IN THIS PARAGRAPH SURVIVES BETWEEN THE ORIGINAL END USER AND ZF EVEN IF THE EXCLUSIVE REMEDY SET FORTH ABOVE IS DEEMED TO FAIL OF ITS ESSENTIAL PURPOSE. ZF may change the design or make improvements to its Products without incurring any warranty obligation for previously manufactured Product .
- (9) Entire Agreement. This is the entire agreement between ZF and the Owner about warranty and no, ZF employee, or dealer is authorized to make any additional warranty on behalf of ZF unless in writing and signed by an authorized representative of ZF.





**For further product details contact your distributor or the
WABCO Customer Care Center at 855-228-3203.**

About ZF Friedrichshafen AG

ZF is a global technology company and supplies systems for passenger cars, commercial vehicles and industrial technology, enabling the next generation of mobility. ZF allows vehicles to see, think and act. In the four technology domains Vehicle Motion Control, Integrated Safety, Automated Driving, and Electric Mobility, ZF offers comprehensive solutions for established vehicle manufacturers and newly emerging transport and mobility service providers. ZF electrifies different kinds of vehicles. With its products, the company contributes to reducing emissions and protecting the climate.

ZF, which acquired WABCO Holdings Inc. on May 29, 2020, now has 160,000 employees worldwide with approximately 260 locations in 41 countries. In 2019, the two then-independent companies achieved sales of €36.5 billion (ZF) and \$3.4 billion (WABCO). For more information, visit: www.wabco-na.com



Fire and Rescue Apparatus

Ten (10) Year Structural Integrity

Custom Cab

Limited Warranty

1. LIMITED WARRANTY

Subject to the limitations and exclusions set forth below, Pierce Manufacturing provides the following warranty to the Buyer:

Coverage:	The Pierce Custom Cab shall be free from structural failures caused by defects in material and workmanship
Warranty Begins:	The date of the original purchase invoice (issued when the product ships from the factory).
Warranty Period Ends After:	Ten (10) Years - or - 100,000 Miles
Conditions and Exclusions: See Also Paragraphs 2 thru 4	This warranty applies only to the cab tubular support and mounting structures and other structural components of the cab of the vehicle model, as identified in the Pierce specifications for the Fire and Rescue Apparatus. This warranty does not apply to damage caused by corrosion.

This limited warranty shall apply only if the product is properly maintained in accordance with Pierce's maintenance instructions and manuals and is used in service which is normal to the particular model. Normal service means service which does not subject the product to stresses or impacts greater than normally result from careful use. If the Buyer discovers a defect or nonconformity, it must notify Pierce in writing within thirty (30) days after the date of discovery, but in any event prior to the expiration of the warranty period. THIS LIMITED WARRANTY MAY NOT BE ASSIGNED OR OTHERWISE TRANSFERRED BY THE BUYER TO ANY SUBSEQUENT USER OR PURCHASER OR TO ANY OTHER PERSON OR ENTITY.

Notwithstanding anything to the contrary herein, Pierce makes no warranty whatsoever as to:

(a) any integral parts, components, attachments or trade accessories of or to the product that are not manufactured by Pierce, including but not limited to engines, transmissions, drivelines, axles, water pumps and generators; with respect to all such parts, components, attachments and accessories, Pierce shall assign to Buyer the applicable warranties, if any, made by the respective manufacturers thereof;

(b) any vehicle, chassis, or component, part, attachment or accessory damaged by misuse, neglect, fire, exposure to severe environmental or chemical conditions, acidic environment, improper maintenance, accident, crash, or force majeure such as natural disaster, lightning, earthquake, windstorm, hail, flood, war or riot;

(c) any vehicle, chassis or component, part, attachment or accessory that has been repaired, altered or assembled in any way by any person or entity other than Pierce which, in the sole judgment of Pierce, adversely affects the performance, stability or purpose for which it was manufactured; or

(d) products or parts which may in the ordinary course wear out and have to be replaced during the warranty period, including, but not limited to, tires, fluids, gaskets and light bulbs. Pierce assumes no responsibility for the assembly of its parts or subassemblies into finishing products or vehicles unless the assembly is performed by Pierce.

The original purchaser may void this warranty in part or in its entirety if the product is repaired or replaced (a) without prior written approval of the Pierce Customer Service Department; or (b) at a facility which has not been approved by Pierce as to technical capability. Any repairs, modifications, alterations or aftermarket parts added after manufacture without the authorization of Pierce may void this warranty.

2. DISCLAIMERS OF WARRANTIES

THE WARRANTY SET FORTH IN PARAGRAPH 1 IS THE SOLE AND EXCLUSIVE WARRANTY GIVEN BY PIERCE. PIERCE HEREBY DISCLAIMS AND EXCLUDES ALL OTHER WARRANTIES, WHETHER EXPRESS, IMPLIED OR STATUTORY, INCLUDING WITHOUT LIMITATION ANY WARRANTY OF MERCHANTABILITY, ANY WARRANTY OF FITNESS FOR A PARTICULAR PURPOSE, AND ANY WARRANTIES ARISING FROM COURSE OF DEALING OR USAGE OF TRADE.

3. BUYER'S EXCLUSIVE REMEDY

If the product fails to conform to the warranty set forth in paragraph 1 during the warranty period, and such nonconformity is not due to misuse, neglect, accident or improper maintenance, Buyer must notify Pierce within the time period specified in paragraph 1, and shall make the product available for inspection by Pierce or its designated agent. At the request of Pierce, any allegedly defective product shall be returned to Pierce by Buyer for examination and/or repair. Buyer shall be responsible for the cost of such transportation, and for risk of loss of or damage to the product during transportation. Within a reasonable time, Pierce shall repair or replace (at Pierce's option and expense) any nonconforming or defective parts. Repair or replacement shall be made only by a facility approved in advance in writing by Pierce. THIS REMEDY SHALL BE THE EXCLUSIVE AND SOLE REMEDY FOR ANY BREACH OF WARRANTY.

4. EXCLUSION OF CONSEQUENTIAL AND INCIDENTAL DAMAGES

Notwithstanding anything to the contrary herein or in any agreement between Pierce and Buyer, IN NO EVENT SHALL PIERCE BE LIABLE FOR ANY CONSEQUENTIAL, INCIDENTAL, SPECIAL, INDIRECT, OR PUNITIVE DAMAGES WHATSOEVER, WHETHER ARISING OUT OF BREACH OF CONTRACT, WARRANTY, TORT (INCLUDING NEGLIGENCE AND STRICT LIABILITY) OR OTHER THEORY OF LAW OR EQUITY, WITH RESPECT TO VEHICLES OR OTHER PRODUCTS SOLD BY PIERCE, OR THEIR OPERATION OR FAILURE TO OPERATE, OR ANY DEFECTS THEREIN, OR ANY UNDERTAKINGS, ACTS OR OMISSIONS RELATED THERETO, REGARDLESS OF WHETHER PIERCE HAS BEEN INFORMED OF THE POSSIBILITY OF ANY SUCH DAMAGES. Without limiting the generality of the foregoing, Pierce specifically disclaims any liability for property or personal injury damages, penalties, damages for lost profits or revenues, loss of vehicles or products or any associated equipment, cost of substitute vehicles or products, down-time, delay damages, any other types of economic loss, or for any claims by any third party for any such damages.

Note: Any Surety Bond, if a part of the sale of the vehicle as to which this limited warranty is provided, applies only to this Pierce Basic One Year Limited Warranty for such vehicle, and not to other warranties made by Pierce in a separate document (if any) or to the warranties (if any) made by any manufacturer (other than Pierce) of any part, component, attachment or accessory that is incorporated into or attached to the vehicle.



Fire and Rescue Apparatus

Ten (10) Year Pro-Rated Paint and Corrosion

Cab

Limited Warranty

1. LIMITED WARRANTY

Subject to the limitations and exclusions set forth below, Pierce Manufacturing provides the following warranty to the Buyer:

Coverage:	Exterior surfaces of the cab painted by Pierce shall be free from blistering, peeling, corrosion or any other adhesion defect caused by defective manufacturing methods or paint material selection.
Warranty Begins:	The date of the original purchase invoice (issued when the product ships from the factory).
Warranty Period Ends After:	Ten (10) Years
Conditions and Exclusions: See Also Paragraphs 2 thru 4	<p>This limited warranty is applicable to the vehicle in the following percentage costs of warranty repair, if any:</p> <p>Topcoat Durability & Appearance: Gloss, Color Retention & Cracking 0-72 months 100% 73-96 months 50% 97-120 months 25%</p> <p>Integrity of Coating System: Adhesion, Blistering/Bubbling 0-36 months 100% 37-84 months 50% 85-120 months 25%</p> <p>Corrosion: Dissimilar Metal and Crevice 0-36 months 100% 37-48 months 50% 49-72 months 25% 73-120 months 10%</p> <p>Corrosion Perforation 0-120 months 100%</p> <p>This limited warranty applies only to exterior paint. Paint on the vehicle's interior is warranted only under the Pierce Basic One Year Limited Warranty.</p> <p>Items not covered by this warranty include: (a) Damage from lack of maintenance and cleaning (proper cleaning and maintenance procedures are detailed in the Pierce operation and maintenance manual). (b) UV paint fade. (c) Any cab not manufactured by Pierce.</p>

This limited warranty shall apply only if the product is properly maintained in accordance with Pierce's maintenance instructions and manuals and is used in service which is normal to the particular model. Normal service means service which does not subject the product to stresses or impacts greater than normally result from careful use. If the Buyer discovers a defect or nonconformity, it must notify Pierce in writing within thirty (30) days after the date of discovery, but in any event prior to the expiration of the warranty period. THIS LIMITED WARRANTY MAY NOT BE ASSIGNED OR OTHERWISE TRANSFERRED BY THE BUYER TO ANY SUBSEQUENT USER OR PURCHASER OR TO ANY OTHER PERSON OR ENTITY.

Notwithstanding anything to the contrary herein, Pierce makes no warranty whatsoever as to:

(a) any integral parts, components, attachments or trade accessories of or to the product that are not manufactured by Pierce, including but not limited to engines, transmissions, drivelines, axles, water pumps and generators; with respect to all such parts, components, attachments and accessories, Pierce shall assign to Buyer the applicable warranties, if any, made by the respective manufacturers thereof;

(b) any vehicle, chassis, or component, part, attachment or accessory damaged by misuse, neglect, fire, exposure to severe environmental or chemical conditions, acidic environment, improper maintenance, accident, crash, or force majeure such as natural disaster, lightning, earthquake, windstorm, hail, flood, war or riot;

(c) any vehicle, chassis or component, part, attachment or accessory that has been repaired, altered or assembled in any way by any person or entity other than Pierce which, in the sole judgment of Pierce, adversely affects the performance, stability or purpose for which it was manufactured; or

(d) products or parts which may in the ordinary course wear out and have to be replaced during the warranty period, including, but not limited to, tires, fluids, gaskets and light bulbs. Pierce assumes no responsibility for the assembly of its parts or subassemblies into finishing products or vehicles unless the assembly is performed by Pierce.

The original purchaser may void this warranty in part or in its entirety if the product is repaired or replaced (a) without prior written approval of the Pierce Customer Service Department; or (b) at a facility which has not been approved by Pierce as to technical capability. Any repairs, modifications, alterations or aftermarket parts added after manufacture without the authorization of Pierce may void this warranty.

2. DISCLAIMERS OF WARRANTIES

THE WARRANTY SET FORTH IN PARAGRAPH 1 IS THE SOLE AND EXCLUSIVE WARRANTY GIVEN BY PIERCE. PIERCE HEREBY DISCLAIMS AND EXCLUDES ALL OTHER WARRANTIES, WHETHER EXPRESS, IMPLIED OR STATUTORY, INCLUDING WITHOUT LIMITATION ANY WARRANTY OF MERCHANTABILITY, ANY WARRANTY OF FITNESS FOR A PARTICULAR PURPOSE, AND ANY WARRANTIES ARISING FROM COURSE OF DEALING OR USAGE OF TRADE.

3. BUYER'S EXCLUSIVE REMEDY

If the product fails to conform to the warranty set forth in paragraph 1 during the warranty period, and such nonconformity is not due to misuse, neglect, accident or improper maintenance, Buyer must notify Pierce within the time period specified in paragraph 1, and shall make the product available for inspection by Pierce or its designated agent. At the request of Pierce, any allegedly defective product shall be returned to Pierce by Buyer for examination and/or repair. Buyer shall be responsible for the cost of such transportation, and for risk of loss of or damage to the product during transportation. Within a reasonable time, Pierce shall repair or replace (at Pierce's option and expense) any nonconforming or defective parts. Repair or replacement shall be made only by a facility approved in advance in writing by Pierce. THIS REMEDY SHALL BE THE EXCLUSIVE AND SOLE REMEDY FOR ANY BREACH OF WARRANTY.

4. EXCLUSION OF CONSEQUENTIAL AND INCIDENTAL DAMAGES

Notwithstanding anything to the contrary herein or in any agreement between Pierce and Buyer, IN NO EVENT SHALL PIERCE BE LIABLE FOR ANY CONSEQUENTIAL, INCIDENTAL, SPECIAL, INDIRECT, OR PUNITIVE DAMAGES WHATSOEVER, WHETHER ARISING OUT OF BREACH OF CONTRACT, WARRANTY, TORT (INCLUDING NEGLIGENCE AND STRICT LIABILITY) OR OTHER THEORY OF LAW OR EQUITY, WITH RESPECT TO VEHICLES OR OTHER PRODUCTS SOLD BY PIERCE, OR THEIR OPERATION OR FAILURE TO OPERATE, OR ANY DEFECTS THEREIN, OR ANY UNDERTAKINGS, ACTS OR OMISSIONS RELATED THERETO, REGARDLESS OF WHETHER PIERCE HAS BEEN INFORMED OF THE POSSIBILITY OF ANY SUCH DAMAGES. Without limiting the generality of the foregoing, Pierce specifically disclaims any liability for property or personal injury damages, penalties, damages for lost profits or revenues, loss of vehicles or products or any associated equipment, cost of substitute vehicles or products, down-time, delay damages, any other types of economic loss, or for any claims by any third party for any such damages.

Note: Any Surety Bond, if a part of the sale of the vehicle as to which this limited warranty is provided, applies only to this Pierce Basic One Year Limited Warranty for such vehicle, and not to other warranties made by Pierce in a separate document (if any) or to the warranties (if any) made by any manufacturer (other than Pierce) of any part, component, attachment or accessory that is incorporated into or attached to the vehicle.



Fire and Rescue Apparatus

54 Months Material and Workmanship

Camera System

Limited Warranty

1. LIMITED WARRANTY

Subject to the limitations and exclusions set forth below, Pierce Manufacturing provides the following warranty to the Buyer:

Coverage:	This limited warranty covers repairs to correct any defect related to materials or workmanship of the Sharpvision camera system installed on the apparatus occurring during the warranty period.
Warranty Begins:	The date of delivery.
Warranty Period Ends After:	Fifty - Four (54) months
Conditions and Exclusions: See Also Paragraphs 2 thru 4	This limited warranty does not apply to related wire harnesses, cables, and connectors, which are covered by the Pierce one (1) year basic apparatus limited warranty.

This limited warranty shall apply only if the product is properly maintained in accordance with Pierce's maintenance instructions and manuals and is used in service which is normal to the particular model. Normal service means service which does not subject the product to stresses or impacts greater than normally result from careful use. If the Buyer discovers a defect or nonconformity, it must notify Pierce in writing within thirty (30) days after the date of discovery, but in any event prior to the expiration of the warranty period. THIS LIMITED WARRANTY MAY NOT BE ASSIGNED OR OTHERWISE TRANSFERRED BY THE BUYER TO ANY SUBSEQUENT USER OR PURCHASER OR TO ANY OTHER PERSON OR ENTITY.

Notwithstanding anything to the contrary herein, Pierce makes no warranty whatsoever as to:

(a) any integral parts, components, attachments or trade accessories of or to the product that are not manufactured by Pierce, including but not limited to engines, transmissions, drivelines, axles, water pumps and generators; with respect to all such parts, components, attachments and accessories, Pierce shall assign to Buyer the applicable warranties, if any, made by the respective manufacturers thereof;

(b) any vehicle, chassis, or component, part, attachment or accessory damaged by misuse, neglect, fire, exposure to severe environmental or chemical conditions, acidic environment, improper maintenance, accident, crash, or force majeure such as natural disaster, lightning, earthquake, windstorm, hail, flood, war or riot;

(c) any vehicle, chassis or component, part, attachment or accessory that has been repaired, altered or assembled in any way by any person or entity other than Pierce which, in the sole judgment of Pierce, adversely affects the performance, stability or purpose for which it was manufactured; or

(d) products or parts which may in the ordinary course wear out and have to be replaced during the warranty period, including, but not limited to, tires, fluids, gaskets and light bulbs. Pierce assumes no responsibility for the assembly of its parts or subassemblies into finishing products or vehicles unless the assembly is performed by Pierce.

The original purchaser may void this warranty in part or in its entirety if the product is repaired or replaced (a) without prior written approval of the Pierce Customer Service Department; or (b) at a facility which has not been approved by Pierce as to technical capability. Any repairs, modifications, alterations or aftermarket parts added after manufacture without the authorization of Pierce may void this warranty.

2. DISCLAIMERS OF WARRANTIES

THE WARRANTY SET FORTH IN PARAGRAPH 1 IS THE SOLE AND EXCLUSIVE WARRANTY GIVEN BY PIERCE. PIERCE HEREBY DISCLAIMS AND EXCLUDES ALL OTHER WARRANTIES, WHETHER EXPRESS, IMPLIED OR STATUTORY, INCLUDING WITHOUT LIMITATION ANY WARRANTY OF MERCHANTABILITY, ANY WARRANTY OF FITNESS FOR A PARTICULAR PURPOSE, AND ANY WARRANTIES ARISING FROM COURSE OF DEALING OR USAGE OF TRADE.

3. BUYER'S EXCLUSIVE REMEDY

If the product fails to conform to the warranty set forth in paragraph 1 during the warranty period, and such nonconformity is not due to misuse, neglect, accident or improper maintenance, Buyer must notify Pierce within the time period specified in paragraph 1, and shall make the product available for inspection by Pierce or its designated agent. At the request of Pierce, any allegedly defective product shall be returned to Pierce by Buyer for examination and/or repair. Buyer shall be responsible for the cost of such transportation, and for risk of loss of or damage to the product during transportation. Within a reasonable time, Pierce shall repair or replace (at Pierce's option and expense) any nonconforming or defective parts. Repair or replacement shall be made only by a facility approved in advance in writing by Pierce. THIS REMEDY SHALL BE THE EXCLUSIVE AND SOLE REMEDY FOR ANY BREACH OF WARRANTY.

4. EXCLUSION OF CONSEQUENTIAL AND INCIDENTAL DAMAGES

Notwithstanding anything to the contrary herein or in any agreement between Pierce and Buyer, IN NO EVENT SHALL PIERCE BE LIABLE FOR ANY CONSEQUENTIAL, INCIDENTAL, SPECIAL, INDIRECT, OR PUNITIVE DAMAGES WHATSOEVER, WHETHER ARISING OUT OF BREACH OF CONTRACT, WARRANTY, TORT (INCLUDING NEGLIGENCE AND STRICT LIABILITY) OR OTHER THEORY OF LAW OR EQUITY, WITH RESPECT TO VEHICLES OR OTHER PRODUCTS SOLD BY PIERCE, OR THEIR OPERATION OR FAILURE TO OPERATE, OR ANY DEFECTS THEREIN, OR ANY UNDERTAKINGS, ACTS OR OMISSIONS RELATED THERETO, REGARDLESS OF WHETHER PIERCE HAS BEEN INFORMED OF THE POSSIBILITY OF ANY SUCH DAMAGES. Without limiting the generality of the foregoing, Pierce specifically disclaims any liability for property or personal injury damages, penalties, damages for lost profits or revenues, loss of vehicles or products or any associated equipment, cost of substitute vehicles or products, down-time, delay damages, any other types of economic loss, or for any claims by any third party for any such damages.

Note: Any Surety Bond, if a part of the sale of the vehicle as to which this limited warranty is provided, applies only to this Pierce Basic One Year Limited Warranty for such vehicle, and not to other warranties made by Pierce in a separate document (if any) or to the warranties (if any) made by any manufacturer (other than Pierce) of any part, component, attachment or accessory that is incorporated into or attached to the vehicle.



Fire and Rescue Apparatus

Ten (10) Year Material and Workmanship

Pierce 12V LED Strip Light

Limited Warranty

1. LIMITED WARRANTY

Subject to the limitations and exclusions set forth below, Pierce Manufacturing provides the following warranty to the Buyer:

Coverage:	This limited warranty covers repairs to correct any defect related to materials or workmanship of the Pierce 12V LED strip lights installed on the apparatus occurring during the warranty period.
Warranty Begins:	The date of the original purchase invoice (issued when the product ships from the factory).
Warranty Period Ends After:	Ten (10) Year
Conditions and Exclusions: See Also Paragraphs 2 thru 4	This limited warranty does not apply to related wire harnesses, cables, and connectors, which are covered by the Pierce one (1) year basic apparatus limited warranty.

This limited warranty shall apply only if the product is properly maintained in accordance with Pierce's maintenance instructions and manuals and is used in service which is normal to the particular model. Normal service means service which does not subject the product to stresses or impacts greater than normally result from careful use. If the Buyer discovers a defect or nonconformity, it must notify Pierce in writing within thirty (30) days after the date of discovery, but in any event prior to the expiration of the warranty period. THIS LIMITED WARRANTY MAY NOT BE ASSIGNED OR OTHERWISE TRANSFERRED BY THE BUYER TO ANY SUBSEQUENT USER OR PURCHASER OR TO ANY OTHER PERSON OR ENTITY.

Notwithstanding anything to the contrary herein, Pierce makes no warranty whatsoever as to:

(a) any integral parts, components, attachments or trade accessories of or to the product that are not manufactured by Pierce, including but not limited to engines, transmissions, drivelines, axles, water pumps and generators; with respect to all such parts, components, attachments and accessories, Pierce shall assign to Buyer the applicable warranties, if any, made by the respective manufacturers thereof;

(b) any vehicle, chassis, or component, part, attachment or accessory damaged by misuse, neglect, fire, exposure to severe environmental or chemical conditions, acidic environment, improper maintenance, accident, crash, or force majeure such as natural disaster, lightning, earthquake, windstorm, hail, flood, war or riot;

(c) any vehicle, chassis or component, part, attachment or accessory that has been repaired, altered or assembled in any way by any person or entity other than Pierce which, in the sole judgment of Pierce, adversely affects the performance, stability or purpose for which it was manufactured; or

(d) products or parts which may in the ordinary course wear out and have to be replaced during the warranty period, including, but not limited to, tires, fluids, gaskets and light bulbs. Pierce assumes no responsibility for the assembly of its parts or subassemblies into finishing products or vehicles unless the assembly is performed by Pierce.

The original purchaser may void this warranty in part or in its entirety if the product is repaired or replaced (a) without prior written approval of the Pierce Customer Service Department; or (b) at a facility which has not been approved by Pierce as to technical capability. Any repairs, modifications, alterations or aftermarket parts added after manufacture without the authorization of Pierce may void this warranty.

2. DISCLAIMERS OF WARRANTIES

THE WARRANTY SET FORTH IN PARAGRAPH 1 IS THE SOLE AND EXCLUSIVE WARRANTY GIVEN BY PIERCE. PIERCE HEREBY DISCLAIMS AND EXCLUDES ALL OTHER WARRANTIES, WHETHER EXPRESS, IMPLIED OR STATUTORY, INCLUDING WITHOUT LIMITATION ANY WARRANTY OF MERCHANTABILITY, ANY WARRANTY OF FITNESS FOR A PARTICULAR PURPOSE, AND ANY WARRANTIES ARISING FROM COURSE OF DEALING OR USAGE OF TRADE.

3. BUYER'S EXCLUSIVE REMEDY.

If the product fails to conform to the warranty set forth in paragraph 1 during the warranty period, and such nonconformity is not due to misuse, neglect, accident or improper maintenance, Buyer must notify Pierce within the time period specified in paragraph 1, and shall make the product available for inspection by Pierce or its designated agent. At the request of Pierce, any allegedly defective product shall be returned to Pierce by Buyer for examination and/or repair. Buyer shall be responsible for the cost of such transportation, and for risk of loss of or damage to the product during transportation. Within a reasonable time, Pierce shall repair or replace (at Pierce's option and expense) any nonconforming or defective parts. Repair or replacement shall be made only by a facility approved in advance in writing by Pierce. THIS REMEDY SHALL BE THE EXCLUSIVE AND SOLE REMEDY FOR ANY BREACH OF WARRANTY.

4. EXCLUSION OF CONSEQUENTIAL AND INCIDENTAL DAMAGES.

Notwithstanding anything to the contrary herein or in any agreement between Pierce and Buyer, IN NO EVENT SHALL PIERCE BE LIABLE FOR ANY CONSEQUENTIAL, INCIDENTAL, SPECIAL, INDIRECT, OR PUNITIVE DAMAGES WHATSOEVER, WHETHER ARISING OUT OF BREACH OF CONTRACT, WARRANTY, TORT (INCLUDING NEGLIGENCE AND STRICT LIABILITY) OR OTHER THEORY OF LAW OR EQUITY, WITH RESPECT TO VEHICLES OR OTHER PRODUCTS SOLD BY PIERCE, OR THEIR OPERATION OR FAILURE TO OPERATE, OR ANY DEFECTS THEREIN, OR ANY UNDERTAKINGS, ACTS OR OMISSIONS RELATED THERETO, REGARDLESS OF WHETHER PIERCE HAS BEEN INFORMED OF THE POSSIBILITY OF ANY SUCH DAMAGES. Without limiting the generality of the foregoing, Pierce specifically disclaims any liability for property or personal injury damages, penalties, damages for lost profits or revenues, loss of vehicles or products or any associated equipment, cost of substitute vehicles or products, down-time, delay damages, any other types of economic loss, or for any claims by any third party for any such damages.

Note: Any Surety Bond, if a part of the sale of the vehicle as to which this limited warranty is provided, applies only to this Pierce Basic One Year Limited Warranty for such vehicle, and not to other warranties made by Pierce in a separate document (if any) or to the warranties (if any) made by any manufacturer (other than Pierce) of any part, component, attachment or accessory that is incorporated into or attached to the vehicle.

NEW PRODUCT WARRANTY



**PARTICIPATING OEM SALES
DISTRIBUTOR SALES**

LIMITED WARRANTY ON NEW ALLISON AUTOMATIC TRANSMISSIONS USED IN EMERGENCY VEHICLE APPLICATIONS

Allison Transmission will provide for repairs or replacement, at its option, during the warranty period of each new Allison transmission listed below that is installed in an Emergency Vehicle in accordance with the following terms, conditions, and limitations.

WHAT IS COVERED

- **WARRANTY APPLIES** — This warranty is for new Allison transmission models listed below installed in an Emergency Vehicle and is provided to the original and any subsequent owner(s) of the vehicle during the warranty period.
- **REPAIRS COVERED** — The warranty covers repairs or replacement, at Allison Transmission’s option, to correct any transmission malfunction resulting from defects in material or workmanship occurring during the warranty period. Needed repairs or replacements will be performed using the method Allison Transmission determines most appropriate under the circumstances.
- **TOWING** — Towing is covered to the nearest Allison Transmission Distributor or authorized Dealer only when necessary to prevent further damage to your transmission.
- **PAYMENT TERMS** — Warranty repairs, including parts and labor, will be covered per the schedule shown in the chart contained in section “APPLICABLE MODELS, WARRANTY LIMITATIONS, AND ADJUSTMENT SCHEDULE.”
- **OBTAINING REPAIRS** — To obtain warranty repairs, take the vehicle to any Allison Transmission Distributor or authorized Dealer within a reasonable amount of time and request the needed repairs. A reasonable amount of time must be allowed for the Distributor or Dealer to perform necessary repairs.
- **TRANSMISSION REMOVAL AND REINSTALLATION** — Labor costs for the removal and re-installation of the transmission, when necessary to make a warranty repair, are covered by this warranty.
- **WARRANTY PERIOD** — The warranty period for all coverages shall begin on the date the transmission is delivered to the first retail purchaser, with the following exception:

Demonstration Service - A transmission in a new truck or bus may be demonstrated to a total of 5000 miles (8000 kilometers). If the vehicle is within this limit when sold to a retail purchaser, the warranty start date is the date of purchase. Normal warranty services are applicable to the demonstrating Dealer. Should the truck or bus be sold to a retail purchaser after these limits are reached, the warranty period will begin on the date the vehicle was first placed in demonstration service and the purchaser will be entitled to the remaining warranty.

APPLICABLE MODELS, WARRANTY LIMITATIONS, AND ADJUSTMENT SCHEDULE

APPLICABLE MODELS	WARRANTY LIMITATIONS (Whichever occurs first)		ADJUSTMENT CHARGE TO BE PAID BY THE CUSTOMER	
	Months	Transmission Miles Or Kilometers	Parts	Labor
MT, MD 3000, 3200, 3500, 3700	0-24	No Limit	No Charge	No Charge
HT with Hydraulic Controls	0-24	No Limit	No Charge	No Charge
AT, 1000 Series™, 2000 Series™, 2400 Series™	0-36	No Limit	No Charge	No Charge
HT with Electronic Controls	0-60	No Limit	No Charge	No Charge
HD 1000 EVS, 2100 EVS, 2200 EVS 2350 EVS, 2500 EVS, 2550 EVS, 3000 EVS, 3500 EVS, 4000, 4000 EVS, 4500, 4500 EVS, 4700, 4700 EVS, 4800, 4800 EVS	0-60	No Limit	No Charge	No Charge

WHAT IS NOT COVERED

- **DAMAGE DUE TO ACCIDENT, MISUSE, or ALTERATION** — Defects and damage caused as the result of any of the following are not covered:
 - Flood, collision, fire, theft, freezing, vandalism, riot, explosion, or objects striking the vehicle;
 - Misuse of the vehicle;
 - Installation into unapproved applications and installations;
 - Alterations or modification of the transmission or the vehicle, and
 - Damage resulting from improper storage (refer to long-term storage procedure outlined in the applicable Allison Service Manual)
 - Anything other than defects in Allison Transmission material or workmanship

NOTE: This warranty is void on transmissions used in vehicles currently or previously titled as salvaged, scrapped, junked, or totaled.

- **CHASSIS, BODY, and COMPONENTS** — The chassis and body company (assemblers) and other component and equipment manufacturers are solely responsible for warranties on the chassis, body, component(s), and equipment they provide. Any transmission repair caused by an alteration(s) made to the Allison transmission or the vehicle which allows the transmission to be installed or operated outside of the limits defined in the appropriate Allison Installation Guideline is solely the responsibility of the entity making the alteration(s).
- **DAMAGE CAUSED by LACK of MAINTENANCE or by the USE of TRANSMISSION FLUIDS NOT RECOMMENDED in the OPERATOR'S MANUAL** — Defects and damage caused by any of the following are not covered:
 - Failure to follow the recommendations of the maintenance schedule intervals applicable to the transmission;
 - Failure to use transmission fluids or maintain transmission fluid levels recommended in the Operator's Manual.
- **MAINTENANCE** — Normal maintenance (such as replacement of filters, screens, and transmission fluid) is not covered and is the owner's responsibility.
- **REPAIRS by UNAUTHORIZED DEALERS** — Defects and damage caused by a service outlet that is not an authorized Allison Transmission Distributor or Dealer are not covered.
- **USE of OTHER THAN GENUINE ALLISON TRANSMISSION PARTS** — Defects and damage caused by the use of parts that are not genuine Allison Transmission parts are not covered.
- **EXTRA EXPENSES** — Economic loss and extra expenses are not covered. Examples include but are not limited to: loss of vehicle use; inconvenience; storage; payment for loss of time or pay; vehicle rental expense; lodging; meals; or other travel costs.
- **"DENIED PARTY" OWNERSHIP** — Warranty repair parts and labor costs are not reimbursed to any participating or non-participating OEMs, dealers or distributors who perform warranty work for, or on behalf of, end users identified by the United States as being a "denied party" or who are citizens of sanctioned or embargoed countries as defined by the U.S. Department of Treasury Office of Foreign Assets Control. Furthermore, warranty reimbursements are not guaranteed if the reimbursement would be contrary to any United States export control laws or regulations as defined by the U.S. Department of Commerce, the U.S. Department of State, or the U.S. Department of Treasury.

OTHER TERMS APPLICABLE TO CONSUMERS AS DEFINED by the MAGNUSON-MOSS WARRANTY ACT

This warranty gives you specific legal rights and you may also have other rights which vary from state to state.

Allison Transmission does not authorize any person to create for it any other obligation or liability in connection with these transmissions.

ANY IMPLIED WARRANTY OF MERCHANTABILITY OR FITNESS FOR A PARTICULAR PURPOSE APPLICABLE TO THESE TRANSMISSIONS IS LIMITED IN DURATION TO THE DURATION OF THIS WRITTEN WARRANTY. PERFORMANCE OF REPAIRS AND NEEDED ADJUSTMENTS IS THE EXCLUSIVE REMEDY UNDER THIS WRITTEN WARRANTY OR ANY IMPLIED WARRANTY. ALLISON TRANSMISSION SHALL NOT BE LIABLE FOR INCIDENTAL OR CONSEQUENTIAL DAMAGES (SUCH AS, BUT NOT LIMITED TO, LOST WAGES OR VEHICLE RENTAL EXPENSES) RESULTING FROM BREACH OF THIS WRITTEN WARRANTY OR ANY IMPLIED WARRANTY.**

** Some states do not allow limitations on how long an implied warranty will last or the exclusion or limitation of incidental or consequential damages, so the above limitations or exclusions may not apply to you.

OTHER TERMS APPLICABLE TO OTHER END-USERS

THIS WARRANTY IS THE ONLY WARRANTY APPLICABLE TO THE ALLISON TRANSMISSION MODELS LISTED ABOVE AND IS EXPRESSLY IN LIEU OF ANY OTHER WARRANTIES, EXPRESS OR IMPLIED, INCLUDING ANY IMPLIED WARRANTY OF MERCHANTABILITY OR FITNESS FOR A PARTICULAR PURPOSE. ALLISON TRANSMISSION DOES NOT AUTHORIZE ANY PERSON TO CREATE FOR IT ANY OTHER OBLIGATION OR LIABILITY IN CONNECTION WITH SUCH TRANSMISSIONS. ALLISON TRANSMISSION SHALL NOT BE LIABLE FOR INCIDENTAL OR CONSEQUENTIAL DAMAGES RESULTING FROM BREACH OF THIS WARRANTY OR ANY IMPLIED WARRANTY.

QUESTIONS

If you have any questions regarding this warranty or the performance of warranty obligations, you may contact any Allison Transmission Distributor or Dealer or write to:

Allison Transmission, Inc.
P.O. Box 894
Indianapolis, IN 46206-0894
Attention: Warranty Administration PF-9



Fire and Rescue Apparatus

Five (5) Year Material and Workmanship - Transmission Oil Cooler Three (3) Year Collateral Damage Coverage

Limited Warranty

1. LIMITED WARRANTY

Subject to the limitations and exclusions set forth below, Pierce Manufacturing provides the following warranty to the Buyer:

Coverage:	The transmission cooler shall be free from component or structural failures caused by defects in material and/or workmanship. Collateral damage up to \$10,000 per occurrence is available for the first three (3) years.
Warranty Begins:	The date of delivery to the first retail purchaser.
Warranty Period Ends After:	Five (5) Years on Oil Cooler and three (3) years on collateral damage coverage
Conditions and Exclusions: See Also Paragraphs 2 thru 4	<p>This warranty does not cover repair due to accidents, misuse, and excessive vibration, flying debris, storage damage (freezing), negligence or modification. This warranty is void if any modification or repairs are performed without authorization. This also voids any future warranty.</p> <p>This warranty does not cover cost of maintenance or repairs due to lack of required maintenance services as recommended. Performance of the required maintenance and use of proper fluids are the responsibility of the owner.</p> <p>Towing is covered to the nearest distributor or authorized dealer only when necessary to prevent further damage to your transmission.</p> <p>Labor costs for the removal and reinstallation of goods may be covered when necessary to make repairs. Please contact your OEM for authorization.</p> <p>Replacement of cooler during the warranty period is limited to 100% of reasonable labor costs up to a maximum of \$700 to remove, replace, or repair the oil cooler.</p>

This limited warranty shall apply only if the product is properly maintained in accordance with Pierce's maintenance instructions and manuals and is used in service which is normal to the particular model. Normal service means service which does not subject the product to stresses or impacts greater than normally result from careful use. If the Buyer discovers a defect or nonconformity, it must notify Pierce in writing within thirty (30) days after the date of discovery, but in any event prior to the expiration of the warranty period. THIS LIMITED WARRANTY MAY NOT BE ASSIGNED OR OTHERWISE TRANSFERRED BY THE BUYER TO ANY SUBSEQUENT USER OR PURCHASER OR TO ANY OTHER PERSON OR ENTITY.

Notwithstanding anything to the contrary herein, Pierce makes no warranty whatsoever as to:

(a) any integral parts, components, attachments or trade accessories of or to the product that are not manufactured by Pierce, including but not limited to engines, transmissions, drivelines, axles, water pumps and generators; with respect to all such parts, components, attachments and accessories, Pierce shall assign to Buyer the applicable warranties, if any, made by the respective manufacturers thereof;

(b) any vehicle, chassis, or component, part, attachment or accessory damaged by misuse, neglect, fire, exposure to severe environmental or chemical conditions, acidic environment, improper maintenance, accident, crash, or force majeure such as natural disaster, lightning, earthquake, windstorm, hail, flood, war or riot;

(c) any vehicle, chassis or component, part, attachment or accessory that has been repaired, altered or assembled in any way by any person or entity other than Pierce which, in the sole judgment of Pierce, adversely affects the performance, stability or purpose for which it was manufactured; or

(d) products or parts which may in the ordinary course wear out and have to be replaced during the warranty period, including, but not limited to, tires, fluids, gaskets and light bulbs. Pierce assumes no responsibility for the assembly of its parts or subassemblies into finishing products or vehicles unless the assembly is performed by Pierce.

The original purchaser may void this warranty in part or in its entirety if the product is repaired or replaced (a) without prior written approval of the Pierce Customer Service Department; or (b) at a facility which has not been approved by Pierce as to technical capability. Any repairs, modifications, alterations or aftermarket parts added after manufacture without the authorization of Pierce may void this warranty.

2. DISCLAIMERS OF WARRANTIES

THE WARRANTY SET FORTH IN PARAGRAPH 1 IS THE SOLE AND EXCLUSIVE WARRANTY GIVEN BY PIERCE. PIERCE HEREBY DISCLAIMS AND EXCLUDES ALL OTHER WARRANTIES, WHETHER EXPRESS, IMPLIED OR STATUTORY, INCLUDING WITHOUT LIMITATION ANY WARRANTY OF MERCHANTABILITY, ANY WARRANTY OF FITNESS FOR A PARTICULAR PURPOSE, AND ANY WARRANTIES ARISING FROM COURSE OF DEALING OR USAGE OF TRADE.

3. BUYER'S EXCLUSIVE REMEDY.

If the product fails to conform to the warranty set forth in paragraph 1 during the warranty period, and such nonconformity is not due to misuse, neglect, accident or improper maintenance, Buyer must notify Pierce within the time period specified in paragraph 1, and shall make the product available for inspection by Pierce or its designated agent. At the request of Pierce, any allegedly defective product shall be returned to Pierce by Buyer for examination and/or repair. Buyer shall be responsible for the cost of such transportation, and for risk of loss of or damage to the product during transportation. Within a reasonable time, Pierce shall repair or replace (at Pierce's option and expense) any nonconforming or defective parts. Repair or replacement shall be made only by a facility approved in advance in writing by Pierce. THIS REMEDY SHALL BE THE EXCLUSIVE AND SOLE REMEDY FOR ANY BREACH OF WARRANTY.

4. EXCLUSION OF CONSEQUENTIAL AND INCIDENTAL DAMAGES.

Notwithstanding anything to the contrary herein or in any agreement between Pierce and Buyer, IN NO EVENT SHALL PIERCE BE LIABLE FOR ANY CONSEQUENTIAL, INCIDENTAL, SPECIAL, INDIRECT, OR PUNITIVE DAMAGES WHATSOEVER, WHETHER ARISING OUT OF BREACH OF CONTRACT, WARRANTY, TORT (INCLUDING NEGLIGENCE AND STRICT LIABILITY) OR OTHER THEORY OF LAW OR EQUITY, WITH RESPECT TO VEHICLES OR OTHER PRODUCTS SOLD BY PIERCE, OR THEIR OPERATION OR FAILURE TO OPERATE, OR ANY DEFECTS THEREIN, OR ANY UNDERTAKINGS, ACTS OR OMISSIONS RELATED THERETO, REGARDLESS OF WHETHER PIERCE HAS BEEN INFORMED OF THE POSSIBILITY OF ANY SUCH DAMAGES. Without limiting the generality of the foregoing, Pierce specifically disclaims any liability for property or personal injury damages, penalties, damages for lost profits or revenues, loss of vehicles or products or any associated equipment, cost of substitute vehicles or products, down-time, delay damages, any other types of economic loss, or for any claims by any third party for any such damages.

Note: Any Surety Bond, if a part of the sale of the vehicle as to which this limited warranty is provided, applies only to this Pierce Basic One Year Limited Warranty for such vehicle, and not to other warranties made by Pierce in a separate document (if any) or to the warranties (if any) made by any manufacturer (other than Pierce) of any part, component, attachment or accessory that is incorporated into or attached to the vehicle.



LIFETIME SERVICE WARRANTY

United Plastic Fabricating, Inc. (hereinafter called "UPF") warrants each POLY-TANK®, Booster/Foam Tank POLYSIDE® Wetside Tank, Integrator Tank/Body, ELLIPSE™ Elliptical Tank, Ellip-T-Tank Tank and DEFENDER™ Skid Tank to be free from defects in material and workmanship for the service life of the original vehicle (vehicle must be actively used in an emergency response for suppression). All UPF Tanks must be installed and operated in accordance with the UPF Installation and Operating Guidelines. Failure to do so can void the warranty.

Every UPF Tank is inspected and tested before leaving our facility. Should your UPF Tank require service, please notify UPF via email, fax, in writing or by calling UPF at 1-978-975-4520. Please provide the serial number, a description of the service request, the location along with the phone number and name of the contact person. Our goal is to have scheduled work completed within a reasonable time period.

Under a valid warranty claim, UPF will cover the cost to repair the UPF Tank including the customary and reasonable costs to make the tank accessible such as the removal and reinstallation of the tank if authorized in advance (pre-approved) by UPF. The warranty will not cover tanks that have been improperly installed, operated, misused, abused, or from its intended or designed use. Serial number must not have been altered, defaced or removed. Tanks that are not stored or installed properly which results in the tank suffering UV damage will not be covered by this agreement.

Should UPF determine that the service claim is valid under this warranty for a tank located outside of the United States and Canada, UPF will assume the costs for labor and material for the warranty repair as described above plus all travel costs to the U.S. port of embarkation. Costs for airline travel outside of the U.S. and Canada will not be the responsibility of UPF.

In the event the tank shall become stationed in an area of the world that is considered to be a war zone or where unsafe conditions exist for the safe passage of United States Nationals, as reported by the United States Department of State, (<http://www.state.gov>), and a request to perform service or warranty repairs, UPF reserves the right to refuse to honor such requests. It is the purchaser's responsibility to relocate the tank to an area where such repairs can be performed without undue risk to UPF employees or their designee. UPF will make every reasonable effort to support our products through alternative means.

For Ellipse™ elliptical tanks, a separate year warranty provided by the subcontractor is applied to the sub-frames, chute linings (rubber isolation strips) and metal components. The stainless steel wrap provided by UPF shall be warranted by the subcontractor performing the wrap installation in accordance with their warranty in place at the time of the installation. UPF will not be liable for any warranty costs associated with the wrap, sub-frames, chute linings (rubber isolation strips) and metal components but will assist with all claims on behalf of its customer.

For PolySide® wetsided tanks and Integrator™ Tank/Body units, all polypropylene components related to the tank shall carry the standard UPF lifetime



UNITED PLASTIC FABRICATING, INC.

WARRANTY

FOR: POLY-TANK®, POLYSIDE®, INTEGRATOR™, ELLIPSE™, ELLIP-T-TANK™ & DEFENDER™

service warranty. Other polypropylene components, including but not limited to compartments, wheel wells, fenders and other body related components shall be warranted by UPF for a period of ten years. The warranty for the PolySide® and Integrator™ units excludes paint or hardware, which shall be covered by the manufacturer of the paint/hardware.

All UPF tanks 50 gallons or less utilized for applications and installed on specialty vehicles such as ATVs, trailers, boats, etc. are covered under a separate warranty policy available from UPF. Further, UPF Protector™ foam and water trailers are warranted under a separate warranty policy available from UPF.

This UPF warranty is transferable within the United States only with prior written approval by UPF (except an original apparatus manufacturer may assign

UPF will NOT reimburse any unnecessary work and/or work that has not been pre-approved. Any and all third party charges must be pre-authorized and approved in writing by UPF prior to commencing the work. Any unauthorized third party repairs, alterations, actions or modifications will not be covered and can void the warranty. UPF will be the sole determining authority as to whether a service claim will be valid and covered under this warranty.

In no event will UPF be liable for an amount in excess of the purchase price of the booster/foam tank at the time of manufacture or for any loss or damage, whether direct, indirect, incidental, consequential, or otherwise arising out of failure of its product. Loss of contents (water, foam, etc.) shall not be the responsibility of UPF. Further, UPF is not responsible for costs associated with service repairs to chassis, sub-frames, bodies, valves, dumps, hoses, pressure vacuum vents, and other components (i.e. liquid level transducers, etc.). Further, UPF will not cover the cost for travel of the vehicle to and from a repair facility.

This warranty contains the entire warranty. It is the sole warranty and price agreements or representation, whether oral or written, are either merged herein or expressly cancelled. UPF neither assumes, nor authorizes any person supposing to act on its behalf to change, nor assume for it, any warranty or liability concerning its product.

This warranty gives you legal rights, and you may also have other rights which vary from state to state. Some states do not allow exclusion or limitation or incidental or consequential damage, so the above limitation or exclusion may not apply to you. Since some states do not allow limitations on the length of an implied warranty, the above limitation may not apply to you.

THERE ARE NO WARRANTIES, EXPRESSED OR IMPLIED, WHICH EXTEND BEYOND THE DESCRIPTION OF THE FACE HEREOF. THERE IS NO EXPRESS OR IMPLIED WARRANTY OF MERCHANTABILITY OR A WARRANTY OF FITNESS FOR A PARTICULAR PURPOSE. ADDITIONALLY, THIS WARRANTY IS IN LIEU OF ALL OTHER OBLIGATION OR LIABILITIES ON THE PART OF UPF.



BULLETIN

TO: All Dealer Service Representatives

From: Kevin Hanegraaf

DATE: January 4, 2010

RE: UPF Tank Warranty Policy – Truck in Accident

Service Topic #292



To keep the UPF tank warranty valid on trucks that have been involved in a vehicular accident, it is UPF's policy that the customer must remove the tank from the truck and send it back to one of UPF's facilities for inspection. In the event that this does not take place, the warranty will be considered null and void.

The customer must remove and send the tank back to UPF for inspection in order to maintain the original warranty coverage, at which time it will be:

- Filled with water
- Visually inspected
- Ultraviolet spark tested on articulating test stand in the dark
- Recommendation for repairs if necessary provided by UPF
- Fully evaluated and repaired by UPF

If your customer chooses to leave the tank on the truck and wants a technician to inspect and/or repair the tank in the field, then **the warranty is no longer in effect.** This direction is upheld by UPF because the technician cannot inspect the entire tank when it is still installed on the truck.

Note: This memo is intended to relay the information Pierce has received on UPF's tank warranty for trucks that are in a vehicular accident. In the event of an actual claim, we direct you to consult with UPF's service Manager Maura Watts (800-638-8265 x253)



Fire and Rescue Apparatus

Ten (10) Year Structural Integrity Apparatus Body

Limited Warranty

1. LIMITED WARRANTY

Subject to the limitations and exclusions set forth below, Pierce Manufacturing provides the following warranty to the Buyer:

Coverage:	The apparatus body shall be free from structural failures caused by defects in material and workmanship
Warranty Begins:	The date of the original purchase invoice (issued when the product ships from the factory).
Warranty Period Ends After:	Ten (10) Years - or - 100,000 Miles
Conditions and Exclusions: See Also Paragraphs 2 thru 4	This warranty applies only to the body tubular support and mounting structures and other structural components of the body of the vehicle model, as identified in the Pierce specifications for the Fire and Rescue Apparatus. This warranty does not apply to damage caused by corrosion.

This limited warranty shall apply only if the product is properly maintained in accordance with Pierce's maintenance instructions and manuals and is used in service which is normal to the particular model. Normal service means service which does not subject the product to stresses or impacts greater than normally result from careful use. If the Buyer discovers a defect or nonconformity, it must notify Pierce in writing within thirty (30) days after the date of discovery, but in any event prior to the expiration of the warranty period. THIS LIMITED WARRANTY MAY NOT BE ASSIGNED OR OTHERWISE TRANSFERRED BY THE BUYER TO ANY SUBSEQUENT USER OR PURCHASER OR TO ANY OTHER PERSON OR ENTITY.

Notwithstanding anything to the contrary herein, Pierce makes no warranty whatsoever as to:

(a) any integral parts, components, attachments or trade accessories of or to the product that are not manufactured by Pierce, including but not limited to engines, transmissions, drivelines, axles, water pumps and generators; with respect to all such parts, components, attachments and accessories, Pierce shall assign to Buyer the applicable warranties, if any, made by the respective manufacturers thereof;

(b) any vehicle, chassis, or component, part, attachment or accessory damaged by misuse, neglect, fire, exposure to severe environmental or chemical conditions, acidic environment, improper maintenance, accident, crash, or force majeure such as natural disaster, lightning, earthquake, windstorm, hail, flood, war or riot;

(c) any vehicle, chassis or component, part, attachment or accessory that has been repaired, altered or assembled in any way by any person or entity other than Pierce which, in the sole judgment of Pierce, adversely affects the performance, stability or purpose for which it was manufactured; or

(d) products or parts which may in the ordinary course wear out and have to be replaced during the warranty period, including, but not limited to, tires, fluids, gaskets and light bulbs. Pierce assumes no responsibility for the assembly of its parts or subassemblies into finishing products or vehicles unless the assembly is performed by Pierce.

The original purchaser may void this warranty in part or in its entirety if the product is repaired or replaced (a) without prior written approval of the Pierce Customer Service Department; or (b) at a facility which has not been approved by Pierce as to technical capability. Any repairs, modifications, alterations or aftermarket parts added after manufacture without the authorization of Pierce may void this warranty.

2. DISCLAIMERS OF WARRANTIES

THE WARRANTY SET FORTH IN PARAGRAPH 1 IS THE SOLE AND EXCLUSIVE WARRANTY GIVEN BY PIERCE. PIERCE HEREBY DISCLAIMS AND EXCLUDES ALL OTHER WARRANTIES, WHETHER EXPRESS, IMPLIED OR STATUTORY, INCLUDING WITHOUT LIMITATION ANY WARRANTY OF MERCHANTABILITY, ANY WARRANTY OF FITNESS FOR A PARTICULAR PURPOSE, AND ANY WARRANTIES ARISING FROM COURSE OF DEALING OR USAGE OF TRADE.

3. BUYER'S EXCLUSIVE REMEDY

If the product fails to conform to the warranty set forth in paragraph 1 during the warranty period, and such nonconformity is not due to misuse, neglect, accident or improper maintenance, Buyer must notify Pierce within the time period specified in paragraph 1, and shall make the product available for inspection by Pierce or its designated agent. At the request of Pierce, any allegedly defective product shall be returned to Pierce by Buyer for examination and/or repair. Buyer shall be responsible for the cost of such transportation, and for risk of loss of or damage to the product during transportation. Within a reasonable time, Pierce shall repair or replace (at Pierce's option and expense) any nonconforming or defective parts. Repair or replacement shall be made only by a facility approved in advance in writing by Pierce. THIS REMEDY SHALL BE THE EXCLUSIVE AND SOLE REMEDY FOR ANY BREACH OF WARRANTY.

4. EXCLUSION OF CONSEQUENTIAL AND INCIDENTAL DAMAGES

Notwithstanding anything to the contrary herein or in any agreement between Pierce and Buyer, IN NO EVENT SHALL PIERCE BE LIABLE FOR ANY CONSEQUENTIAL, INCIDENTAL, SPECIAL, INDIRECT, OR PUNITIVE DAMAGES WHATSOEVER, WHETHER ARISING OUT OF BREACH OF CONTRACT, WARRANTY, TORT (INCLUDING NEGLIGENCE AND STRICT LIABILITY) OR OTHER THEORY OF LAW OR EQUITY, WITH RESPECT TO VEHICLES OR OTHER PRODUCTS SOLD BY PIERCE, OR THEIR OPERATION OR FAILURE TO OPERATE, OR ANY DEFECTS THEREIN, OR ANY UNDERTAKINGS, ACTS OR OMISSIONS RELATED THERETO, REGARDLESS OF WHETHER PIERCE HAS BEEN INFORMED OF THE POSSIBILITY OF ANY SUCH DAMAGES. Without limiting the generality of the foregoing, Pierce specifically disclaims any liability for property or personal injury damages, penalties, damages for lost profits or revenues, loss of vehicles or products or any associated equipment, cost of substitute vehicles or products, down-time, delay damages, any other types of economic loss, or for any claims by any third party for any such damages.

Note: Any Surety Bond, if a part of the sale of the vehicle as to which this limited warranty is provided, applies only to this Pierce Basic One Year Limited Warranty for such vehicle, and not to other warranties made by Pierce in a separate document (if any) or to the warranties (if any) made by any manufacturer (other than Pierce) of any part, component, attachment or accessory that is incorporated into or attached to the vehicle.



Pierce Warranty Statement for Gortite Roll Up Doors Rev 2/24/2011

All mechanical components of the door shall be warranted to be free from defects in materials and workmanship for the lifetime of the vehicle. All parts covered under this warranty shall be to the original owner.

A&A manufacturing warrants that painted doors shall be free of blistering, peeling, bubbling, or any other adhesion defect caused by defective manufacturing methods or paint material selection. The time period for the coverage shall be 6 years from date of door shipment to Pierce. Satin anodized finish doors shall be warranted for 6 years against corrosion defects from date of door shipment to Pierce. Replacement of decals/Scotchlite is not covered.

The maximum amount A&A will reimburse for labor is \$60.00 per hour and the maximum amount of time allowed for repair is as follows:

Door	1.0 Hr.
Slat Replacement	1.0 Hr.
Pennant Plate Replacement	1.0 Hr.
Roller Replacement	.5 Hr.
Seal Replacement	.5 Hr.
Switch/Magnet Replacement	1.0 Hr.
Travel Time	4.0 Hr.

Waterous Seven-Year Limited Warranty

WATEROUS warrants, to the original Buyer only, that products manufactured by WATEROUS will be free from defects in material and workmanship under normal use and service for a period of seven (7) years from the date the product is first placed in service, or seven and one-half (7-1/2) years from the date of shipment by WATEROUS, whichever period shall be the first to expire; provided the Buyer notifies WATEROUS, in writing, of the defect in said product within the warranty period, and said product is found by WATEROUS to be nonconforming with the aforesaid warranty. When required in writing by WATEROUS, defective products must be promptly returned by Buyer to WATEROUS at WATEROUS' plant at South St. Paul, Minnesota, or at such other place as may be specified by WATEROUS, with transportation and other charges prepaid. A Returned Material Authorization (RMA) is required for all products and parts and may be requested by phone, fax, email, or mail. The aforesaid warranty excludes any responsibility or liability of WATEROUS for:

- (a) damages or defects due to accident, abuse, misuse, abnormal operating conditions, negligence, accidental causes, use in non-reighting applications, or improper maintenance, or attributable to written specifications or instructions furnished by Buyer;
- (b) defects in products manufactured by others and furnished by WATEROUS hereunder, it being understood and agreed by the parties that the only warranty provided for such products shall be the warranty provided by the manufacturer thereof which, if assignable, WATEROUS will assign to Buyer, if requested by Buyer;
- (c) any product or part, altered, modified, serviced or repaired other than by WATEROUS, without its prior written consent;
- (d) the cost of dismantling, removing, transporting, storing, or insuring the defective product or part and the cost of reinstallation; and
- (e) normal wear items (packing, strainers, filters, light bulbs, anodes, intake screens, mechanical seals, etc.).

ALL OTHER WARRANTIES ARE EXCLUDED, WHETHER EXPRESS OR IMPLIED BY OPERATION OF LAW OR OTHERWISE, INCLUDING ALL IMPLIED WARRANTIES OF MERCHANTABILITY OR FITNESS FOR A PARTICULAR PURPOSE. IN NO EVENT, WHETHER AS A RESULT OF BREACH OF CONTRACT, WARRANTY, TORT (INCLUDING NEGLIGENCE), STRICT LIABILITY, OR ANY OTHER CAUSE OF ACTION, SHALL WATEROUS BE LIABLE FOR ANY PUNITIVE, SPECIAL, INCIDENTAL OR CONSEQUENTIAL DAMAGES, OR FOR PERSONAL INJURY OR PROPERTY DAMAGES.

The exclusive remedy of Buyer and the sole liability of WATEROUS, whether based on contract, warranty, tort or any other basis of recovery whatsoever, is expressly limited at the election of WATEROUS to:

- (a) the replacement at the agreed point of delivery of any product or part, which upon inspection by WATEROUS or its duly authorized representative, is found not to conform to the limited warranty set forth above, or
- (b) the repair of such product or part, or
- (c) the refund or crediting to Buyer of the net sales price of the defective product or part.

BUYER'S REMEDIES CONTAINED HEREIN ARE EXCLUSIVE OF ANY OTHER REMEDY OTHERWISE AVAILABLE TO BUYER.

Waterous Company
125 Hardman Avenue South
South St. Paul, MN 55075 USA
www.waterousco.com





Ten (10) Year Material and Workmanship
Stainless Steel Piping
Limited Warranty

1. LIMITED WARRANTY

Subject to the limitations and exclusions set forth below, Pierce Manufacturing provides the following warranty to the Buyer:

Table with 2 columns: Label (Coverage, Warranty Begins, Warranty Period Ends After, Conditions and Exclusions) and Description (Stainless steel piping shall be free from structural failures... The date of the original purchase invoice... Ten (10) Years - or - 100,000 Miles... Pierce's obligation under this warranty is limited to repairing or replacing without charge... This warranty does not cover the use of fluoroprotein (FP) type foam...)

Notwithstanding anything to the contrary herein, Pierce makes no warranty whatsoever as to:

- (a) any integral parts, components, attachments or trade accessories of or to the product that are not manufactured by Pierce...
(b) any vehicle, chassis, or component, part, attachment or accessory damaged by misuse, neglect, fire, exposure to severe environmental or chemical conditions...
(c) any vehicle, chassis or component, part, attachment or accessory that has been repaired, altered or assembled in any way by any person or entity other than Pierce...
(d) products or parts which may in the ordinary course wear out and have to be replaced during the warranty period...

The original purchaser may void this warranty in part or in its entirety if the product is repaired or replaced (a) without prior written approval of the Pierce Customer Service Department; or (b) at a facility which has not been approved by Pierce as to technical capability.

2. DISCLAIMERS OF WARRANTIES

THE WARRANTY SET FORTH IN PARAGRAPH 1 IS THE SOLE AND EXCLUSIVE WARRANTY GIVEN BY PIERCE. PIERCE HEREBY DISCLAIMS AND EXCLUDES ALL OTHER WARRANTIES, WHETHER EXPRESS, IMPLIED OR STATUTORY, INCLUDING WITHOUT LIMITATION ANY WARRANTY OF MERCHANTABILITY, ANY WARRANTY OF FITNESS FOR A PARTICULAR PURPOSE, AND ANY WARRANTIES ARISING FROM COURSE OF DEALING OR USAGE OF TRADE.

3. BUYER'S EXCLUSIVE REMEDY

If the product fails to conform to the warranty set forth in paragraph 1 during the warranty period, and such nonconformity is not due to misuse, neglect, accident or improper maintenance, Buyer must notify Pierce within the time period specified in paragraph 1, and shall make the product available for inspection by Pierce or its designated agent. At the request of Pierce, any allegedly defective product shall be returned to Pierce by Buyer for examination and/or repair.

4. EXCLUSION OF CONSEQUENTIAL AND INCIDENTAL DAMAGES

Notwithstanding anything to the contrary herein or in any agreement between Pierce and Buyer, IN NO EVENT SHALL PIERCE BE LIABLE FOR ANY CONSEQUENTIAL, INCIDENTAL, SPECIAL, INDIRECT, OR PUNITIVE DAMAGES WHATSOEVER, WHETHER ARISING OUT OF BREACH OF CONTRACT, WARRANTY, TORT (INCLUDING NEGLIGENCE AND STRICT LIABILITY) OR OTHER THEORY OF LAW OR EQUITY, WITH RESPECT TO VEHICLES OR OTHER PRODUCTS SOLD BY PIERCE, OR THEIR OPERATION OR FAILURE TO OPERATE, OR ANY DEFECTS THEREIN, OR ANY UNDERTAKINGS, ACTS OR OMISSIONS RELATED THERETO, REGARDLESS OF WHETHER PIERCE HAS BEEN INFORMED OF THE POSSIBILITY OF ANY SUCH DAMAGES.

Note: Any Surety Bond, if a part of the sale of the vehicle as to which this limited warranty is provided, applies only to this Pierce Basic One Year Limited Warranty for such vehicle, and not to other warranties made by Pierce in a separate document (if any) or to the warranties (if any) made by any manufacturer (other than Pierce) of any part, component, attachment or accessory that is incorporated into or attached to the vehicle.

This limited warranty shall apply only if the product is properly maintained in accordance with Pierce's maintenance instructions and manuals and is used in service which is normal to the particular model. Normal service means service which does not subject the product to stresses or impacts greater than normally result from careful use.



One (1) Year Material and Workmanship Foam System & Five (5) Year Material and Workmanship Control Head

Limited Warranty

1. LIMITED WARRANTY

Subject to the limitations and exclusions set forth below, Pierce Manufacturing provides the following warranty to the Buyer:

Coverage:	Limited warranty 1 year parts and labor for the foam system and 5 years parts and labor for the control head.
Warranty Begins:	The date of the original purchase invoice (issued when the product ships from the factory).
Warranty Period Ends After:	One (1) Year & Five (5) Year
Conditions and Exclusions: See Also Paragraphs 2 thru 4	<p>This warranty does not cover repair due to accidents, misuse, and excessive vibration, flying debris, storage damage (freezing), negligence or modification. This warranty is void if any modification or repairs are performed without authorization. This also voids any future warranty.</p> <p>This warranty does not cover cost of maintenance or repairs due to lack of required maintenance services as recommended. Performance of the required maintenance and use of proper fluids are the responsibility of the owner.</p>

Notwithstanding anything to the contrary herein, Pierce makes no warranty whatsoever as to:

(a) any integral parts, components, attachments or trade accessories of or to the product that are not manufactured by Pierce, including but not limited to engines, transmissions, drivelines, axles, water pumps and generators; with respect to all such parts, components, attachments and accessories, Pierce shall assign to Buyer the applicable warranties, if any, made by the respective manufacturers thereof;

(b) any vehicle, chassis, or component, part, attachment or accessory damaged by misuse, neglect, fire, exposure to severe environmental or chemical conditions, acidic environment, improper maintenance, accident, crash, or force majeure such as natural disaster, lightning, earthquake, windstorm, hail, flood, war or riot;

(c) any vehicle, chassis or component, part, attachment or accessory that has been repaired, altered or assembled in any way by any person or entity other than Pierce which, in the sole judgment of Pierce, adversely affects the performance, stability or purpose for which it was manufactured; or

(d) products or parts which may in the ordinary course wear out and have to be replaced during the warranty period, including, but not limited to, tires, fluids, gaskets and light bulbs. Pierce assumes no responsibility for the assembly of its parts or subassemblies into finishing products or vehicles unless the assembly is performed by Pierce.

The original purchaser may void this warranty in part or in its entirety if the product is repaired or replaced (a) without prior written approval of the Pierce Customer Service Department; or (b) at a facility which has not been approved by Pierce as to technical capability. Any repairs, modifications, alterations or aftermarket parts added after manufacture without the authorization of Pierce may void this warranty.

2. DISCLAIMERS OF WARRANTIES

THE WARRANTY SET FORTH IN PARAGRAPH 1 IS THE SOLE AND EXCLUSIVE WARRANTY GIVEN BY PIERCE. PIERCE HEREBY DISCLAIMS AND EXCLUDES ALL OTHER WARRANTIES, WHETHER EXPRESS, IMPLIED OR STATUTORY, INCLUDING WITHOUT LIMITATION ANY WARRANTY OF MERCHANTABILITY, ANY WARRANTY OF FITNESS FOR A PARTICULAR PURPOSE, AND ANY WARRANTIES ARISING FROM COURSE OF DEALING OR USAGE OF TRADE.

3. BUYER'S EXCLUSIVE REMEDY.

If the product fails to conform to the warranty set forth in paragraph 1 during the warranty period, and such nonconformity is not due to misuse, neglect, accident or improper maintenance, Buyer must notify Pierce within the time period specified in paragraph 1, and shall make the product available for inspection by Pierce or its designated agent. At the request of Pierce, any allegedly defective product shall be returned to Pierce by Buyer for examination and/or repair. Buyer shall be responsible for the cost of such transportation, and for risk of loss of or damage to the product during transportation. Within a reasonable time, Pierce shall repair or replace (at Pierce's option and expense) any nonconforming or defective parts. Repair or replacement shall be made only by a facility approved in advance in writing by Pierce. THIS REMEDY SHALL BE THE EXCLUSIVE AND SOLE REMEDY FOR ANY BREACH OF WARRANTY.

4. EXCLUSION OF CONSEQUENTIAL AND INCIDENTAL DAMAGES.

Notwithstanding anything to the contrary herein or in any agreement between Pierce and Buyer, IN NO EVENT SHALL PIERCE BE LIABLE FOR ANY CONSEQUENTIAL, INCIDENTAL, SPECIAL, INDIRECT, OR PUNITIVE DAMAGES WHATSOEVER, WHETHER ARISING OUT OF BREACH OF CONTRACT, WARRANTY, TORT (INCLUDING NEGLIGENCE AND STRICT LIABILITY) OR OTHER THEORY OF LAW OR EQUITY, WITH RESPECT TO VEHICLES OR OTHER PRODUCTS SOLD BY PIERCE, OR THEIR OPERATION OR FAILURE TO OPERATE, OR ANY DEFECTS THEREIN, OR ANY UNDERTAKINGS, ACTS OR OMISSIONS RELATED THERETO, REGARDLESS OF WHETHER PIERCE HAS BEEN INFORMED OF THE POSSIBILITY OF ANY SUCH DAMAGES. Without limiting the generality of the foregoing, Pierce specifically disclaims any liability for property or personal injury damages, penalties, damages for lost profits or revenues, loss of vehicles or products or any associated equipment, cost of substitute vehicles or products, down-time, delay damages, any other types of economic loss, or for any claims by any third party for any such damages.

Note: Any Surety Bond, if a part of the sale of the vehicle as to which this limited warranty is provided, applies only to this Pierce Basic One Year Limited Warranty for such vehicle, and not to other warranties made by Pierce in a separate document (if any) or to the warranties (if any) made by any manufacturer (other than Pierce) of any part, component, attachment or accessory that is incorporated into or attached to the vehicle.

This limited warranty shall apply only if the product is properly maintained in accordance with Pierce's maintenance instructions and manuals and is used in service which is normal to the particular model. Normal service means service which does not subject the product to stresses or impacts greater than normally result from careful use. If the Buyer discovers a defect or nonconformity, it must notify Pierce in writing within thirty (30) days after the date of discovery, but in any event prior to the expiration of the warranty period. THIS LIMITED WARRANTY MAY NOT BE ASSIGNED OR OTHERWISE TRANSFERRED BY THE BUYER TO ANY SUBSEQUENT USER OR PURCHASER OR TO ANY OTHER PERSON OR ENTITY.



MANUFACTURER'S LIMITED WARRANTY - HYDRAULIC GENERATORS

STANDARD

Harrison Hydra-Gen® (Seller) extends to the original purchaser (Buyer) of goods for use (whether it be an OEM, dealer, re-seller, or end-user) the following warranty covering the Harrison Hydra-Gen® Generator System, subject to the qualifications indicated. Harrison Hydra-Gen® Generator Systems shall consist of a Harrison generator tray assembly and its' components, a Harrison hydraulic pump assembly, and a Harrison supplied meter assembly; unless otherwise specified in below guidelines.

Harrison Hydra-Gen® warrants the original purchaser that the Generator System manufactured or supplied by Harrison Hydra-Gen® will be free from defects in materials and workmanship, provided such goods are:

1. Installed, operated and maintained in accordance with the Harrison Hydra-Gen® owner's manual, and/or written installation addendums.
2. Each new application has been reviewed and approved by the Harrison Hydra-Gen® Application Engineering Group.

PERIOD OF WARRANTY

*Two (2) years or 2000 hours of usage, whichever comes first, from the date the product is shipped from Harrison to the Installer.

***The END USER must complete and return to Harrison Hydra-Gen® the Harrison Hydra-Gen® Warranty Registration Card, Form WR-1, provided in the generator manual and provided online @ www.harrisonhydragen.com, within 45 days of delivery.**

Warranty includes all parts and labor. In addition, maintenance items that are contaminated or damaged by a proven warrantable failure are covered in years 1-2, and Labor time up to 4 hours, travel time up to 2.5 hours, and mileage up to 100 miles for warranty related repairs are covered.



Repair or replacement parts are warranted for ninety (90) days from date of purchase, excluding labor and travel expenses. Any part repaired or replaced during the warranty period assumes the remainder of the warranty or ninety (90) days, whichever is greater.

Only components supplied by Harrison Hydra-Gen® are covered under this warranty.

There is no other express warranty. Implied warranties, including merchantability and fitness for a particular purpose, are limited to periods set forth above and to the extent permitted by law. Any and all implied warranties are excluded. In no event is Harrison Hydra-Gen® liable for incidental or consequential damages.

The Buyer (OEM, dealer, re-seller, or end-user) must notify Harrison Hydra-Gen®, an Authorized Distributor, or a designated Harrison Hydra-Gen® Service Representative, **in writing**, within thirty (30) calendar days after goods or parts failed to meet this warranty.

The sole liability of Harrison Hydra-Gen® and the Buyer's sole remedy for a failure of goods under this warranty and for any and all other claims arising out of the purchase and use of the goods, including negligence on the part of the manufacturer, shall be limited to the repair or replacement of the product, at the option of Harrison Hydra-Gen®, of the parts that do not conform to this warranty, provided that the product or parts are returned to the Harrison Hydra-Gen® manufacturing facility.

A Returned Goods Authorization (RGA) is required for all products and parts being returned, and may be requested by phone, fax, email, or mail.

Failure to make timely delivery to Harrison Hydra-Gen® of the goods claimed to be defective shall void any warranty.

Unless previous written agreements have been made between the Buyer and Harrison Hydra-Gen®, the Buyer shall be responsible for all freight and shipping charges in connection with the delivery of the goods claimed to be defective, to Harrison Hydra-Gen® at its manufacturing facility, and the return of repaired or replacement goods to the Buyer.

If Harrison Hydra-Gen® determines that no warranty coverage is available for goods claimed to be defective, whether determination is based on the warranty being voided, the product failure

being due to a cause not covered by the warranty, the failure to make a timely and proper warranty claim, or otherwise, the Buyer shall have the option of either:

1. Having the goods not repaired and returned to the Buyer, freight collect.
2. Having the goods repaired, If Harrison Hydra-Gen® determines that the product is repairable, and returned to the Buyer, freight collect. The Buyer will be responsible for all costs associated with the repair and testing of the goods and shall authorize Harrison Hydra-Gen®, in writing, to have the goods repaired and tested by Harrison Hydra-Gen®.

The owner is obligated to operate and maintain the goods in accordance with the recommendations published by Harrison Hydra-Gen® in the owner's manual. The owner is responsible for the costs associated with such maintenance and any adjustments that may be required.

This warranty shall not apply to:

1. Damages or defects caused by normal wear, accident, misuse, abuse, abnormal operating conditions, negligence, corrosion, accident causes, or attributable to written specifications or instructions furnished by the installer.
2. Damages or defects caused by improper maintenance in accordance with the Harrison Hydra-Gen® product manuals and operating guidelines.
3. Damages caused by operator error.
4. Damages or defects caused by improper installation.
5. Damages or defects caused by inadequate water drainage provided by the installer in the area where the generator is installed or stored.
6. Damages or defects caused by inadequate air flow space or ventilation provided by the installer in the area where the generator is installed.
7. Any product or part altered or modified by the installer or service facility without written prior consent by Harrison Hydra-Gen®.
8. Cost of normal maintenance, adjustments, installation or start-up.
9. Normal wear items and components needing periodic maintenance such a rubber hoses and filters.
10. Excessive labor due to components being concealed in vehicle as a result of installation.
11. Water, road debris, excessive dirt, salt, abrasive particles, or large foreign objects found in the generator.
12. Telephone or other communications expense.
13. Paint, hydraulic fluid, and interconnecting hoses (internal or external to system assemblies).



This warranty gives you specific legal rights, and you may also have other rights that may vary from state to state or province to province.

No person is authorized to give any other warranties or to assume any other liabilities behalf of Harrison Hydra-Gen®, unless made or assumed in writing by an officer of Harrison Hydra-Gen®.

Contact Harrison Hydra-Gen® for questions regarding your warranty rights and responsibilities at (281) 807-4420; or visit our website at www.harrisonhydragen.com.



Fire and Rescue Apparatus

Ten (10) Year Pro-Rated Paint and Corrosion

Custom Body

Limited Warranty

1. LIMITED WARRANTY

Subject to the limitations and exclusions set forth below, Pierce Manufacturing provides the following warranty to the Buyer:

Coverage:	Exterior surfaces of the body shall be free from blistering, peeling, corrosion or any other adhesion defect caused by defective manufacturing methods or paint material selection.
Warranty Begins:	The date of the original purchase invoice (issued when the product ships from the factory).
Warranty Period Ends After:	Ten (10) Years
Conditions and Exclusions: See Also Paragraphs 2 thru 4	<p>This limited warranty is applicable to the vehicle in the following percentage costs of warranty repair, if any:</p> <p>Topcoat Durability & Appearance: Gloss, Color Retention & Cracking 0-72 months 100% 73-96 months 50% 97-120 months 25%</p> <p>Integrity of Coating System: Adhesion, Blistering/Bubbling 0-36 months 100% 37-84 months 50% 85-120 months 25%</p> <p>Corrosion: Dissimilar Metal and Crevice 0-36 months 100% 37-48 months 50% 49-72 months 25% 73-120 months 10%</p> <p>Corrosion Perforation 0-120 months 100%</p> <p>This limited warranty applies only to exterior paint. Paint on the vehicle's interior is warranted only under the Pierce Basic One Year Limited Warranty.</p> <p>Items not covered by this warranty include: (a) Damage from lack of maintenance and cleaning (proper cleaning and maintenance procedures are detailed in the Pierce operation and maintenance manual). (b) UV paint fade. (c) Any cab not manufactured by Pierce.</p>

This limited warranty shall apply only if the product is properly maintained in accordance with Pierce's maintenance instructions and manuals and is used in service which is normal to the particular model. Normal service means service which does not subject the product to stresses or impacts greater than normally result from careful use. If the Buyer discovers a defect or nonconformity, it must notify Pierce in writing within thirty (30) days after the date of discovery, but in any event prior to the expiration of the warranty period. THIS LIMITED WARRANTY MAY NOT BE ASSIGNED OR OTHERWISE TRANSFERRED BY THE BUYER TO ANY SUBSEQUENT USER OR PURCHASER OR TO ANY OTHER PERSON OR ENTITY.

Notwithstanding anything to the contrary herein, Pierce makes no warranty whatsoever as to:

(a) any integral parts, components, attachments or trade accessories of or to the product that are not manufactured by Pierce, including but not limited to engines, transmissions, drivelines, axles, water pumps and generators; with respect to all such parts, components, attachments and accessories, Pierce shall assign to Buyer the applicable warranties, if any, made by the respective manufacturers thereof;

(b) any vehicle, chassis, or component, part, attachment or accessory damaged by misuse, neglect, fire, exposure to severe environmental or chemical conditions, acidic environment, improper maintenance, accident, crash, or force majeure such as natural disaster, lightning, earthquake, windstorm, hail, flood, war or riot;

(c) any vehicle, chassis or component, part, attachment or accessory that has been repaired, altered or assembled in any way by any person or entity other than Pierce which, in the sole judgment of Pierce, adversely affects the performance, stability or purpose for which it was manufactured; or

(d) products or parts which may in the ordinary course wear out and have to be replaced during the warranty period, including, but not limited to, tires, fluids, gaskets and light bulbs. Pierce assumes no responsibility for the assembly of its parts or subassemblies into finishing products or vehicles unless the assembly is performed by Pierce.

The original purchaser may void this warranty in part or in its entirety if the product is repaired or replaced (a) without prior written approval of the Pierce Customer Service Department; or (b) at a facility which has not been approved by Pierce as to technical capability. Any repairs, modifications, alterations or aftermarket parts added after manufacture without the authorization of Pierce may void this warranty.

2. DISCLAIMERS OF WARRANTIES

THE WARRANTY SET FORTH IN PARAGRAPH 1 IS THE SOLE AND EXCLUSIVE WARRANTY GIVEN BY PIERCE. PIERCE HEREBY DISCLAIMS AND EXCLUDES ALL OTHER WARRANTIES, WHETHER EXPRESS, IMPLIED OR STATUTORY, INCLUDING WITHOUT LIMITATION ANY WARRANTY OF MERCHANTABILITY, ANY WARRANTY OF FITNESS FOR A PARTICULAR PURPOSE, AND ANY WARRANTIES ARISING FROM COURSE OF DEALING OR USAGE OF TRADE.

3. BUYER'S EXCLUSIVE REMEDY

If the product fails to conform to the warranty set forth in paragraph 1 during the warranty period, and such nonconformity is not due to misuse, neglect, accident or improper maintenance, Buyer must notify Pierce within the time period specified in paragraph 1, and shall make the product available for inspection by Pierce or its designated agent. At the request of Pierce, any allegedly defective product shall be returned to Pierce by Buyer for examination and/or repair. Buyer shall be responsible for the cost of such transportation, and for risk of loss of or damage to the product during transportation. Within a reasonable time, Pierce shall repair or replace (at Pierce's option and expense) any nonconforming or defective parts. Repair or replacement shall be made only by a facility approved in advance in writing by Pierce. THIS REMEDY SHALL BE THE EXCLUSIVE AND SOLE REMEDY FOR ANY BREACH OF WARRANTY.

4. EXCLUSION OF CONSEQUENTIAL AND INCIDENTAL DAMAGES

Notwithstanding anything to the contrary herein or in any agreement between Pierce and Buyer, IN NO EVENT SHALL PIERCE BE LIABLE FOR ANY CONSEQUENTIAL, INCIDENTAL, SPECIAL, INDIRECT, OR PUNITIVE DAMAGES WHATSOEVER, WHETHER ARISING OUT OF BREACH OF CONTRACT, WARRANTY, TORT (INCLUDING NEGLIGENCE AND STRICT LIABILITY) OR OTHER THEORY OF LAW OR EQUITY, WITH RESPECT TO VEHICLES OR OTHER PRODUCTS SOLD BY PIERCE, OR THEIR OPERATION OR FAILURE TO OPERATE, OR ANY DEFECTS THEREIN, OR ANY UNDERTAKINGS, ACTS OR OMISSIONS RELATED THERETO, REGARDLESS OF WHETHER PIERCE HAS BEEN INFORMED OF THE POSSIBILITY OF ANY SUCH DAMAGES. Without limiting the generality of the foregoing, Pierce specifically disclaims any liability for property or personal injury damages, penalties, damages for lost profits or revenues, loss of vehicles or products or any associated equipment, cost of substitute vehicles or products, down-time, delay damages, any other types of economic loss, or for any claims by any third party for any such damages.

Note: Any Surety Bond, if a part of the sale of the vehicle as to which this limited warranty is provided, applies only to this Pierce Basic One Year Limited Warranty for such vehicle, and not to other warranties made by Pierce in a separate document (if any) or to the warranties (if any) made by any manufacturer (other than Pierce) of any part, component, attachment or accessory that is incorporated into or attached to the vehicle.



Fire and Rescue Apparatus

One (1) Year Material and Workmanship

Graphics Fading and Deterioration

Limited Warranty

1. LIMITED WARRANTY

Subject to the limitations and exclusions set forth below, Pierce Manufacturing provides the following warranty to the Buyer:

Coverage:	Each graphic lamination shall be free from defects in material workmanship, fading, and deterioration.
Warranty Begins:	The date the apparatus is placed in service, or 60 days from the original buyer invoice date, whichever comes first.
Warranty Period Ends After:	One (1) Year
Conditions and Exclusions: See Also Paragraphs 2 thru 4	This warranty does not cover damage from lack of maintenance and cleaning (proper cleaning and maintenance procedures are detailed in the Pierce operation and maintenance manual).

This limited warranty shall apply only if the product is properly maintained in accordance with Pierce's maintenance instructions and manuals and is used in service which is normal to the particular model. Normal service means service which does not subject the product to stresses or impacts greater than normally result from careful use. If the Buyer discovers a defect or nonconformity, it must notify Pierce in writing within thirty (30) days after the date of discovery, but in any event prior to the expiration of the warranty period. THIS LIMITED WARRANTY MAY NOT BE ASSIGNED OR OTHERWISE TRANSFERRED BY THE BUYER TO ANY SUBSEQUENT USER OR PURCHASER OR TO ANY OTHER PERSON OR ENTITY.

Notwithstanding anything to the contrary herein, Pierce makes no warranty whatsoever as to:

(a) any integral parts, components, attachments or trade accessories of or to the product that are not manufactured by Pierce, including but not limited to engines, transmissions, drivelines, axles, water pumps and generators; with respect to all such parts, components, attachments and accessories, Pierce shall assign to Buyer the applicable warranties, if any, made by the respective manufacturers thereof;

(b) any vehicle, chassis, or component, part, attachment or accessory damaged by misuse, neglect, fire, exposure to severe environmental or chemical conditions, acidic environment, improper maintenance, accident, crash, or force majeure such as natural disaster, lightning, earthquake, windstorm, hail, flood, war or riot;

(c) any vehicle, chassis or component, part, attachment or accessory that has been repaired, altered or assembled in any way by any person or entity other than Pierce which, in the sole judgment of Pierce, adversely affects the performance, stability or purpose for which it was manufactured; or

(d) products or parts which may in the ordinary course wear out and have to be replaced during the warranty period, including, but not limited to, tires, fluids, gaskets and light bulbs. Pierce assumes no responsibility for the assembly of its parts or subassemblies into finishing products or vehicles unless the assembly is performed by Pierce.

The original purchaser may void this warranty in part or in its entirety if the product is repaired or replaced (a) without prior written approval of the Pierce Customer Service Department; or (b) at a facility which has not been approved by Pierce as to technical capability. Any repairs, modifications, alterations or aftermarket parts added after manufacture without the authorization of Pierce may void this warranty.

2. DISCLAIMERS OF WARRANTIES

THE WARRANTY SET FORTH IN PARAGRAPH 1 IS THE SOLE AND EXCLUSIVE WARRANTY GIVEN BY PIERCE. PIERCE HEREBY DISCLAIMS AND EXCLUDES ALL OTHER WARRANTIES, WHETHER EXPRESS, IMPLIED OR STATUTORY, INCLUDING WITHOUT LIMITATION ANY WARRANTY OF MERCHANTABILITY, ANY WARRANTY OF FITNESS FOR A PARTICULAR PURPOSE, AND ANY WARRANTIES ARISING FROM COURSE OF DEALING OR USAGE OF TRADE.

3. BUYER'S EXCLUSIVE REMEDY

If the product fails to conform to the warranty set forth in paragraph 1 during the warranty period, and such nonconformity is not due to misuse, neglect, accident or improper maintenance, Buyer must notify Pierce within the time period specified in paragraph 1, and shall make the product available for inspection by Pierce or its designated agent. At the request of Pierce, any allegedly defective product shall be returned to Pierce by Buyer for examination and/or repair. Buyer shall be responsible for the cost of such transportation, and for risk of loss of or damage to the product during transportation. Within a reasonable time, Pierce shall repair or replace (at Pierce's option and expense) any nonconforming or defective parts. Repair or replacement shall be made only by a facility approved in advance in writing by Pierce. THIS REMEDY SHALL BE THE EXCLUSIVE AND SOLE REMEDY FOR ANY BREACH OF WARRANTY.

4. EXCLUSION OF CONSEQUENTIAL AND INCIDENTAL DAMAGES

Notwithstanding anything to the contrary herein or in any agreement between Pierce and Buyer, IN NO EVENT SHALL PIERCE BE LIABLE FOR ANY CONSEQUENTIAL, INCIDENTAL, SPECIAL, INDIRECT, OR PUNITIVE DAMAGES WHATSOEVER, WHETHER ARISING OUT OF BREACH OF CONTRACT, WARRANTY, TORT (INCLUDING NEGLIGENCE AND STRICT LIABILITY) OR OTHER THEORY OF LAW OR EQUITY, WITH RESPECT TO VEHICLES OR OTHER PRODUCTS SOLD BY PIERCE, OR THEIR OPERATION OR FAILURE TO OPERATE, OR ANY DEFECTS THEREIN, OR ANY UNDERTAKINGS, ACTS OR OMISSIONS RELATED THERETO, REGARDLESS OF WHETHER PIERCE HAS BEEN INFORMED OF THE POSSIBILITY OF ANY SUCH DAMAGES. Without limiting the generality of the foregoing, Pierce specifically disclaims any liability for property or personal injury damages, penalties, damages for lost profits or revenues, loss of vehicles or products or any associated equipment, cost of substitute vehicles or products, down-time, delay damages, any other types of economic loss, or for any claims by any third party for any such damages.

Note: Any Surety Bond, if a part of the sale of the vehicle as to which this limited warranty is provided, applies only to this Pierce Basic One Year Limited Warranty for such vehicle, and not to other warranties made by Pierce in a separate document (if any) or to the warranties (if any) made by any manufacturer (other than Pierce) of any part, component, attachment or accessory that is incorporated into or attached to the vehicle.



Certification Document CD0156 Statement of Compliance to NFPA 1901-2016 Vehicle Stability

Pierce fire apparatus comply with NFPA 1901 Section 4.13 Vehicle Stability using the tilt table method. As prescribed by the standard, each apparatus is compared to a substantially similar apparatus that has been loaded as required and tested on a tilt table per the SAE J2180 test procedure. If the apparatus configuration was not expected to meet the minimum tilt table criteria, then it will be equipped with the Electronic Stability Control option. A listing of all tested apparatus is maintained by the Research and Development lab and is available for inspection at the Appleton factory.



4.13 Vehicle Stability.

4.13.1* Rollover Stability. The apparatus shall meet the criteria defined in 4.13.1.1, or it shall be equipped with a stability control system in accordance with 4.13.1.2.

4.13.1.1 The apparatus shall meet the criteria defined in either of the following:

- (1)*The apparatus shall remain stable to 26.5 degrees in both directions when tested on a tilt table in accordance with SAE J2180, *A Tilt Table Procedure for Measuring the Static Rollover Threshold for Heavy Trucks*.
- (2) The calculated or measured center of gravity (CG) shall be no higher than 80 percent of the rear axle track width.

4.13.1.1.1 Compliance shall be certified by testing, calculating, or measuring the apparatus or by comparing the apparatus to a compliant, substantially similar example apparatus, and the certification shall be delivered with the fire apparatus.

4.13.1.1.2 The example apparatus shall be considered substantially similar if it includes a chassis with the same or higher CG height, the same or narrower rear axle track width, the same or greater water tank size and CG height, the same type of front and rear suspension, and the same type and size of aerial device.

4.13.1.1.3 For purposes of 4.13.1.1, the apparatus shall be loaded with fuel, fire-fighting agents, hose, ladders, a weight of 250 lb in each seating position, and weight equivalent to the miscellaneous equipment allowance as defined in Table 12.1.2.

4.13.1.1.3.1 If the apparatus is designed to meet a specified higher equipment loading or larger hose bed capacity or to carry additional ground ladders, these greater loads shall be included in the testing, calculating, or measuring.

4.13.1.1.3.2 The weight added to the fire apparatus for the purpose of test, calculation, or measurement shall be distributed to approximate typical in-service use of the fire apparatus while not exceeding the manufacturer's published individual compartment weight ratings.

4.13.1.2 If the apparatus is equipped with a stability control system, the system shall have, at a minimum, a steering wheel position sensor, a vehicle yaw sensor, a lateral accelerometer, and individual wheel brake controls.

VALIDATION TEST: Multiple Tests

Pierce Manufacturing, Inc.

David W. Archer
Vice President of Engineering
June 1, 2017



Certification Document CD0098 Power Steering System

Pierce Manufacturing, Inc. certifies that the power steering system as installed in our custom chassis meets the requirements of the component supplier, the NFPA 1901 and NFPA 1906 guidelines as applicable, and Pierce internal design standards.

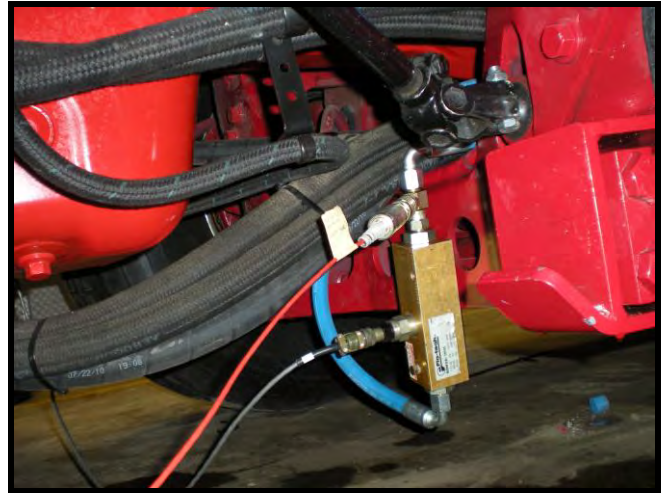

VALIDATION TEST: RD1987, RD2055
RD2056, RD2057, RD2058, RD2059

Pierce Manufacturing, Inc.

A handwritten signature in black ink, appearing to read "David W. Archer".

David W. Archer
Director of Engineering
June 03, 2011

PIERCE MANUFACTURING INC.®

AN OSHKOSH TRUCK CORPORATION® COMPANY



Certification Document CD0189

Saber® FR - Enforcer™

Cab Integrity Certification

Pierce Manufacturing certifies the integrity of the Saber® FR – Enforcer™ cab relative to occupant protection.

A specimen representing the substantial structural configuration of the Saber® FR – Enforcer™ cab models has been successfully tested in accordance with the following standards.

- SAE J2422 Cab Roof Strength Evaluation – Quasi-Static Loading Heavy Trucks.
- European Occupant Protection Standard ECE Regulation No. 29.
- SAE J2420 COE Frontal Strength Evaluation – Dynamic Loading Heavy Trucks.

Side Impact: The test cab was subjected to dynamic preload where a 14,320 lb. moving barrier was impacted into the top corner with sufficient speed to impact the top corner of the cab with 13,000 ft-lbs. of energy. This satisfies SAE J2422 requirements.



Frontal Impact: The test cab was struck by the 14,320 lb. moving barrier at a speed sufficient to impart the required 65,098 ft-lbs. of energy. Twice the energy required per SAE J2420.



Roof Crush: This test cab was then subjected to a roof crush force of 110,000 lbs. This value exceeds the ECE 29 criteria, which must be equivalent to the front axle rating. This is 4.6 times higher than max. front axle rating.

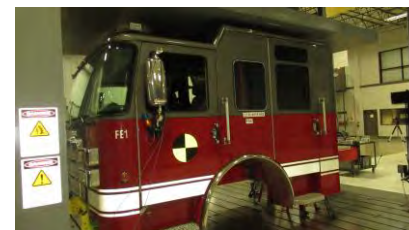

Pass-Fail criteria of the SAE tests and the ECE 29 test is a measure of whether the “survival space” inside the cab is compromised, all doors remain shut, and the cab remained attached to the chassis frame in at least one location. The Pierce cab met all of the Performance Criteria requirements on all 3 integrity tests.

Witnessed and certified by:

Pierce Manufacturing, Inc.

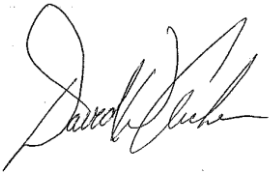
A handwritten signature in black ink, appearing to read "David W Archer". The signature is fluid and cursive, with a large initial "D" and "A".

David W Archer
Vice President of Engineering

PIERCE MANUFACTURING INC.®

AN OSHKOSH CORPORATION® COMPANY



Certification Document CD0137 Saber®FR – Enforcer™ Cab Doors

Pierce Manufacturing certifies the integrity of the Saber®FR – Enforcer™ cab doors.

Specimens representing the substantial structural configuration of the Saber®FR – Enforcer™ cab front and crew doors have been successfully tested to meet the following objectives:

OBJECTIVES:

- Survive a 200,000-cycle door slam test with a slam acceleration up to 20 g's on one representative
- Validate the assembly concept of the main structure of the door by evaluating the durability of the bonding technique.
- Evaluate components, structure, and mounting of the door during and the end of the test for fatigue and failure to ensure durability.
- Verify that the door seals function properly at the end of the test.
- Evaluate the new extrusions and castings of the cab doorframe during and at the end of the test for fatigue, failure, and deformation of seal flanges.
- Evaluate various mounting options for the electronic control module for durability during portions of the slam test.

CONCLUSIONS:

- The door structure and doorframe successfully completed a 200,000-cycle door slam test with a door slam acceleration of 20 g's.

VALIDATION TEST: RD2425

Pierce Manufacturing, Inc.

David Archer
November 18, 2014





Certification Document CD0132 Saber®FR – Enforcer™ Windshield Wiper System

Pierce Manufacturing certifies the integrity of the Saber® FR –Enforcer™ Windshield Wiper System.

Specimens representing the configuration of the Saber® FR –Enforcer™ windshield wipers have been successfully tested to meet the following objectives:

OBJECTIVES:

- Complete 3,000,000 cycles of windshield wiper operation per SAE J198 § 6.2
- Inspect wiper motor, pivots, linkages, and mounts frequently to validate cumulative wiper system integrity.

CONCLUSIONS:

- The wiper linkage, pivots, and mounts successfully completed the 3,000,000 cycles.

VALIDATION TEST: RD2462

Pierce Manufacturing, Inc.

A handwritten signature in black ink, appearing to read "David Archer".

David Archer
Vice President of Engineering

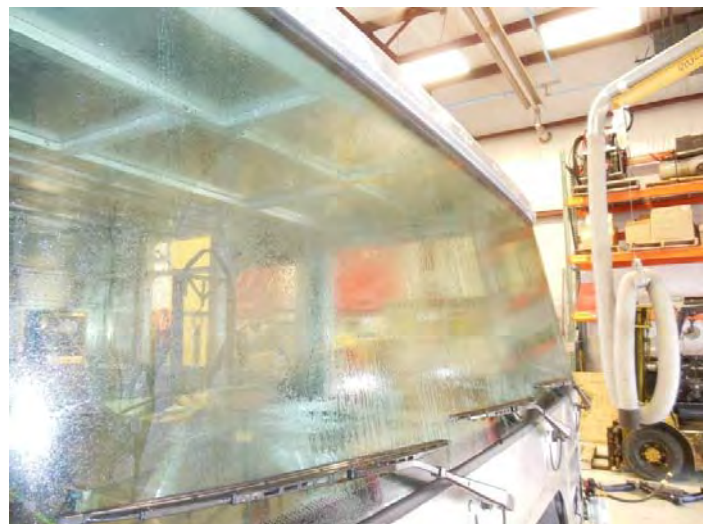



Certification Document CD0134 Saber® FR – Enforcer™ Seats and Seat Belts

Pierce Manufacturing certifies the conformance of the Saber® FR – Enforcer™ cab seats and seat belts to Federal Motor Vehicle Safety Standards. Representative Saber® FR – Enforcer™ Seat and Seat Belt designs have been tested successfully in accordance with FMVSS 207.

Physical testing was performed to qualify passenger seats to meet Federal Motor Vehicle Safety Standards (FMVSS) 207 and 210. This requires that a minimum of 3,000 lbf be applied to both the lap and shoulder belts via appropriate body blocks. A third force of twenty times the mass of the seat must be applied at the center-of-gravity (CG) of the seat. All three forces are applied at the same time, reached within thirty seconds of the start of the test, and be held for a minimum of ten seconds.

A force equal to twenty times the mass of the seat was applied to each seat in the direction opposite to the combination pull. A moment of 275 lb-ft was applied to the seat with reference to the H-point.

This testing ensures that the seat mounting and seat belt anchors are adequate to retain the seats and occupants in a crash. The Federal requirements are based on the high deceleration rates of passenger vehicles, so the design requirements are significantly more conservative considering the slower crash speeds of heavy trucks.

VALIDATION TESTS: RD2397

Pierce Manufacturing, Inc.

David Archer
Vice President of Engineering

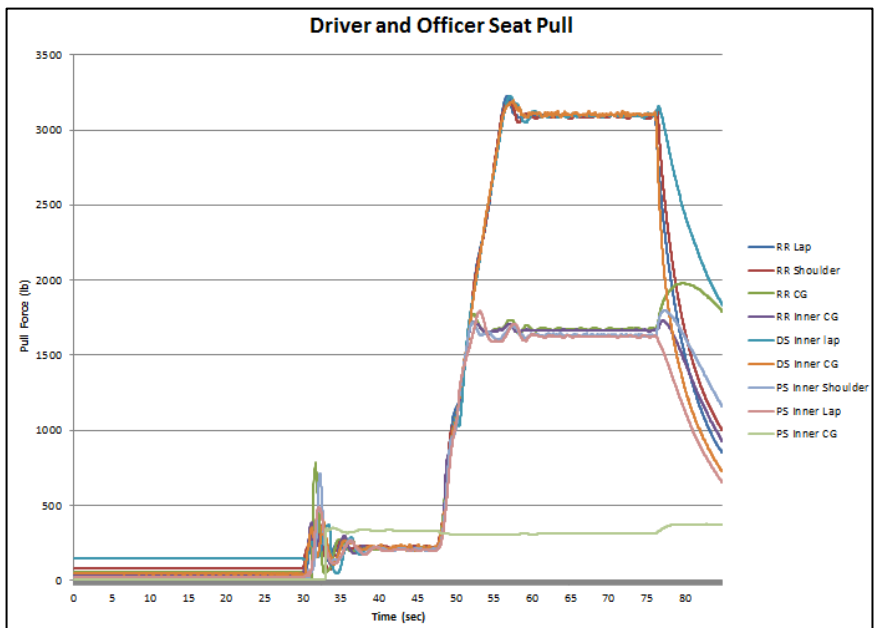

PIERCE MANUFACTURING INC.®

AN OSHKOSH CORPORATION® COMPANY



Certification Document CD0165
Saber® FR – Enforcer™
Cab Heater

Pierce Manufacturing certifies the performance of the Saber® FR – Enforcer™ cab heat systems.

The Saber®FR - Enforcer™ Heater System was tested successfully in an environmental chamber.

Heater testing was performed using the coolant supply procedures from SAE J381. The average cab temperature increased 82.3° F from -10° F to 72.3° F within the prescribed 30 minutes utilizing the right side under seat auxiliary heater. The cab was contained in a cold chamber at -10° F during the duration of the test.

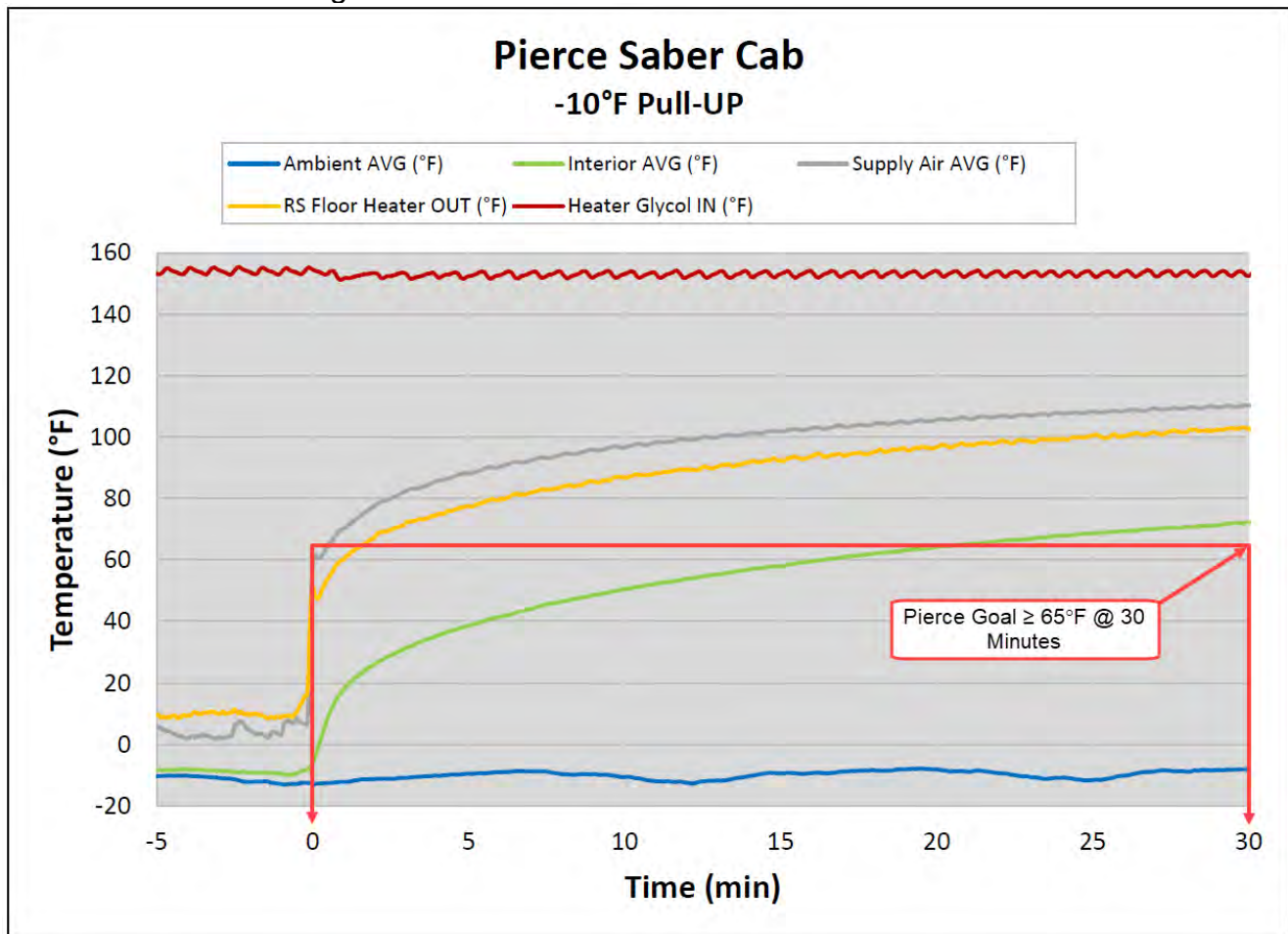

VALIDATION TEST: TR#19-0047 R00

Pierce Manufacturing, Inc.

A handwritten signature in black ink, appearing to read "David Archer". The signature is stylized with a large initial "D" and "A".

David Archer
Vice President of Engineering

PIERCE MANUFACTURING INC.®

AN OSHKOSH CORPORATION® COMPANY



Certification Document CD0167
Saber® FR - Enforcer™
Air Conditioning & Defrost

Pierce Manufacturing certifies the performance of the Saber®FR - Enforcer™ cab air conditioning and defrost system.

The air conditioning and defrost system was tested successfully in an environmental chamber.

Air Conditioning:

Air conditioning performance testing was conducted at an ambient of 100°F and 50 percent relative humidity. The engine speed was maintained at 1000 RPM with the QP21 compressor

The vehicle was heat soaked in the environmental chamber. All temperature probes were monitored to confirm temperature stabilization. The transient test began when all the vehicle doors were closed, and the air conditioning turned on.

The average cab temperature dropped to a maximum of 72.1°F within 30 minutes.

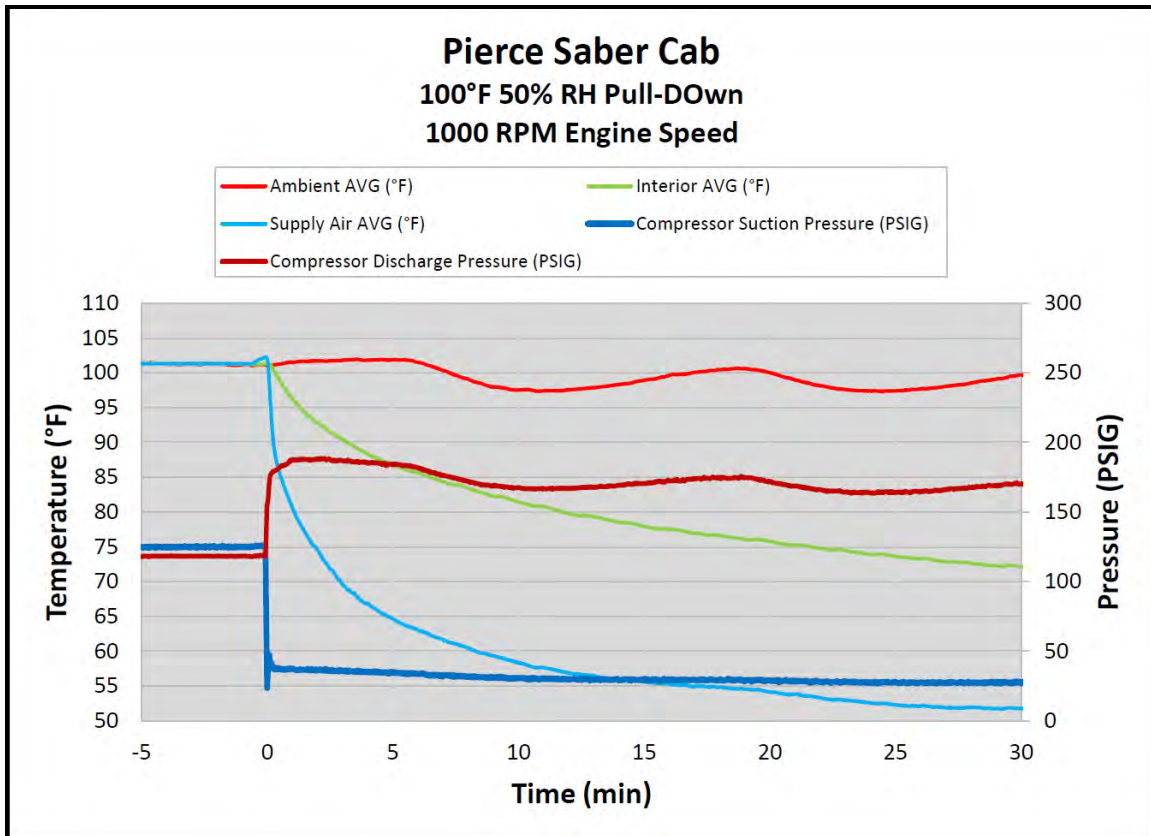

Defrosting

Defroster testing was performed in accordance with *SAE J381 Windshield Defrosting Systems Test Procedure and Performance Requirements-Trucks, Buses, and Multipurpose Vehicles*.

This SAE Recommended Practice establishes uniform test procedures and performance requirements for the defrosting system of enclosed cab trucks, buses, and multipurpose vehicles. Current engineering practice prescribes that for laboratory evaluation of defroster systems, an ice coating of known thickness be applied to the windshield and left- and right-hand side windows to provide more uniform and repeatable test results, even though under actual conditions such a coating would necessarily be scraped off before driving. The test condition, therefore, represents a more severe condition than the actual condition, where the defroster system must merely be capable of maintaining a cleared viewing area.

During the test, the vehicle is cold soaked to 0° F in a cold chamber. A prescribed layer of ice is applied to the windshield. The defroster is then run, and the advancing melt boundary marked as the test proceeds.

The SAE prescribed area of the windshield was 100% cleared and the side windows were 75% cleared within the specified 30-minute period.

Defrost Results

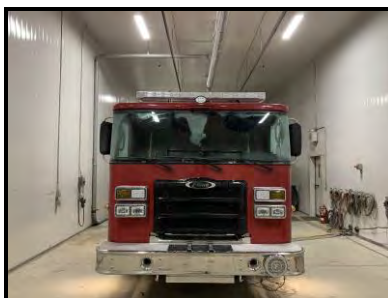
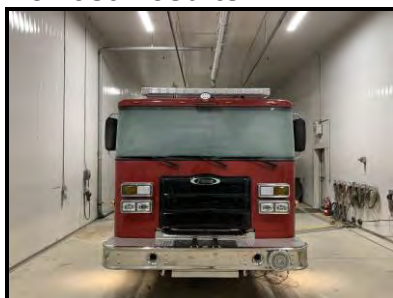

Start of Test

15 Minutes

30 Minutes



Right

Viewed From Outside

Left

VALIDATION TEST: MCC Test Report TR#19-0047 R00

Pierce Manufacturing, Inc.

A handwritten signature in black ink, appearing to read "David W. Archer". The signature is fluid and cursive, with a large initial "D" and "A".

David W. Archer
Vice President of Engineering

PIERCE MANUFACTURING INC.®

AN OSHKOSH CORPORATION® COMPANY



Certification Document CD0174
Saber® FR – Enforcer™
Cab Heater

Pierce Manufacturing, in conjunction with Mobile Climate Control, Inc., certifies the performance of the Saber® FR – Enforcer™ cab heat systems.

The Saber®FR - Enforcer™ Heater System was tested successfully in an environmental chamber.

Heater testing was performed using the coolant supply procedures from SAE J381. The average cab temperature increased 82.3° F from -10° F to 72.3° F within the prescribed 30 minutes utilizing the right side under seat auxiliary heater. The cab was contained in a cold chamber at -10° F during the duration of the test.

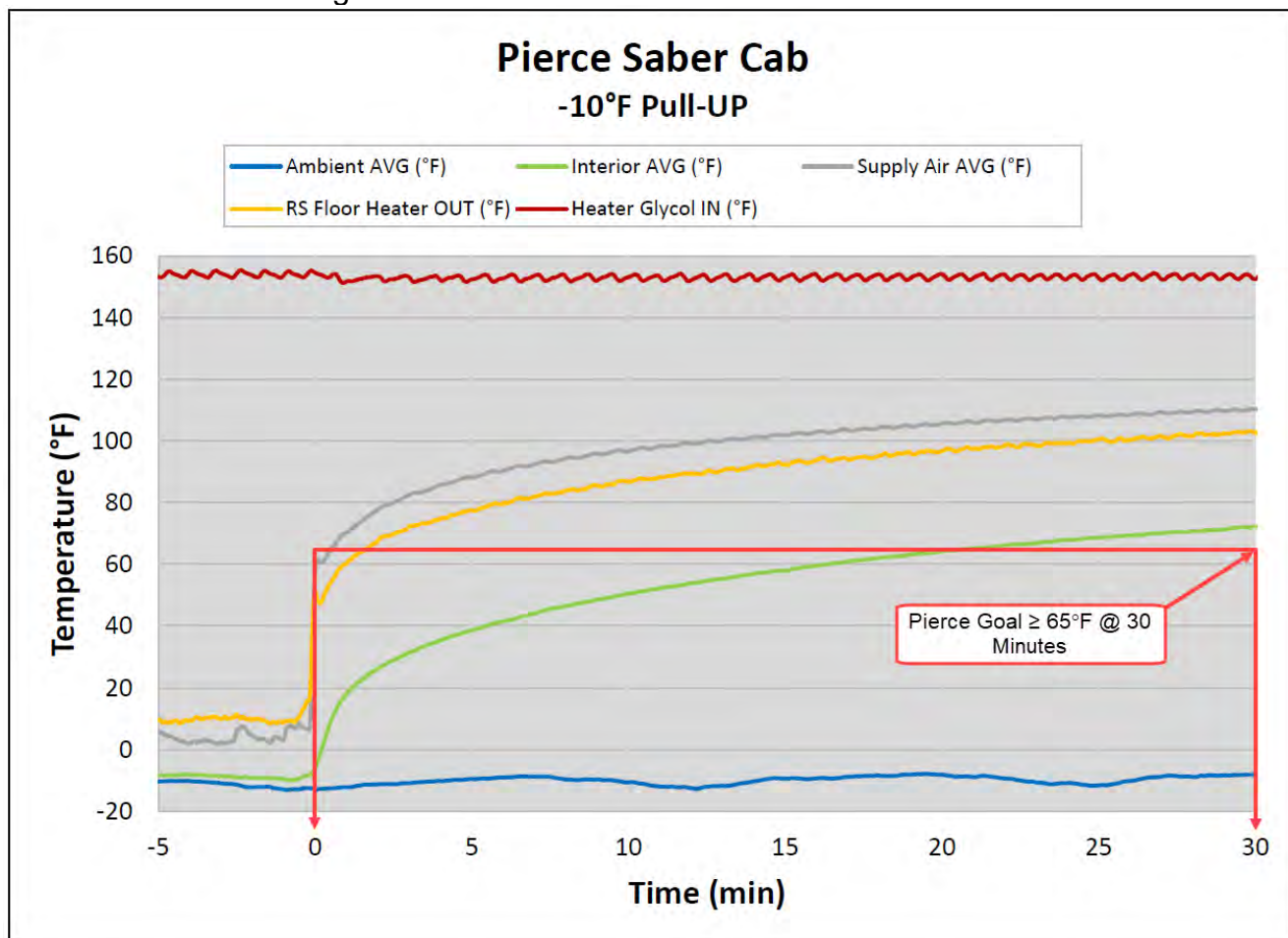

VALIDATION TEST: TR#19-0047 R00

Pierce Manufacturing, Inc.



David Archer
Vice President of Engineering

Mobile Climate Control, Inc.

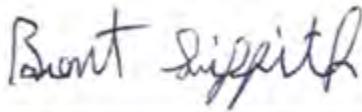

Brent Griffith
Lead Test Engineer & Large Application Specialist

PIERCE MANUFACTURING INC.®

AN OSHKOSH CORPORATION® COMPANY



Certification Document CD0175 Saber® FR - Enforcer™ Air Conditioning & Defrost

Pierce Manufacturing, in conjunction with Mobile Climate Control, Inc., certifies the performance of the Saber®FR - Enforcer™ cab air conditioning and defrost system.

The air conditioning and defrost system was tested successfully in an environmental chamber.

Air Conditioning:

Air conditioning performance testing was conducted at an ambient of 100°F and 50 percent relative humidity. The engine speed was maintained at 1000 RPM with the QP21 compressor

The vehicle was heat soaked in the environmental chamber. All temperature probes were monitored to confirm temperature stabilization. The transient test began when all the vehicle doors were closed, and the air conditioning turned on.

The average cab temperature dropped to a maximum of 72.1°F within 30 minutes.

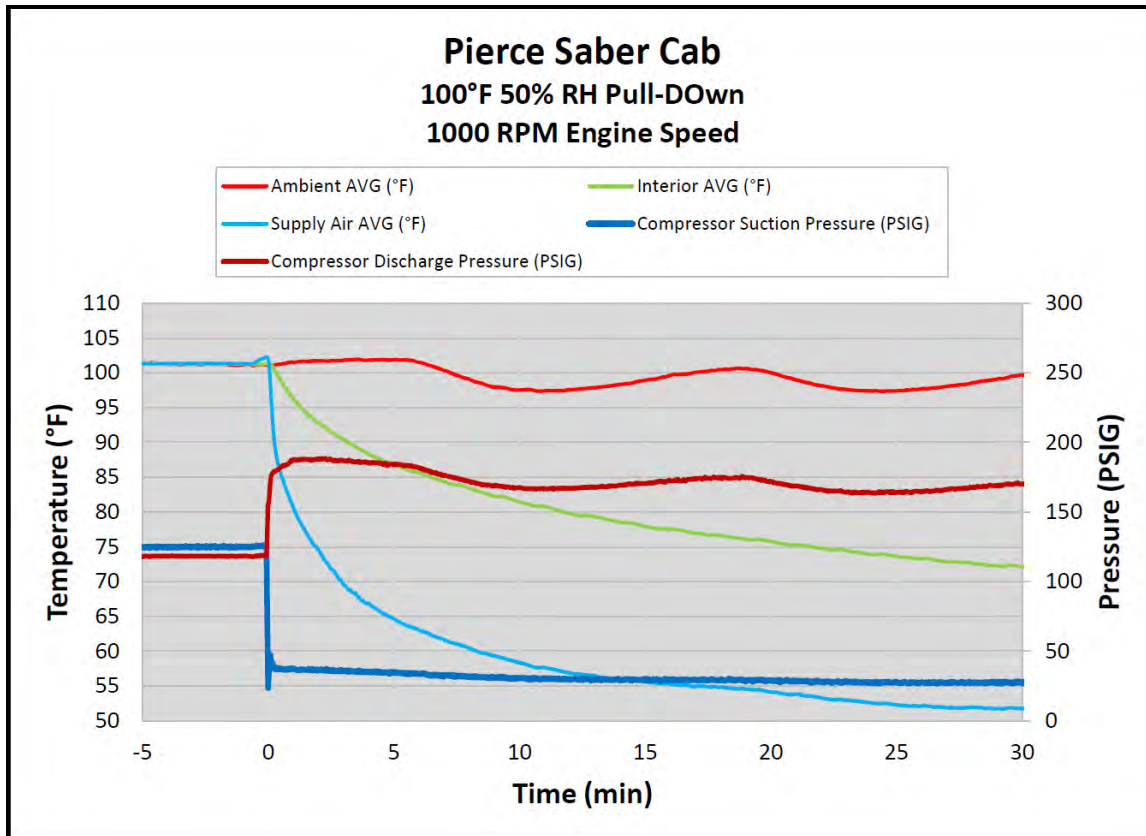

Defrosting

Defroster testing was performed in accordance with *SAE J381 Windshield Defrosting Systems Test Procedure and Performance Requirements-Trucks, Buses, and Multipurpose Vehicles*.

This SAE Recommended Practice establishes uniform test procedures and performance requirements for the defrosting system of enclosed cab trucks, buses, and multipurpose vehicles. Current engineering practice prescribes that for laboratory evaluation of defroster systems, an ice coating of known thickness be applied to the windshield and left- and right-hand side windows to provide more uniform and repeatable test results, even though under actual conditions such a coating would necessarily be scraped off before driving. The test condition, therefore, represents a more severe condition than the actual condition, where the defroster system must merely be capable of maintaining a cleared viewing area.

During the test, the vehicle is cold soaked to 0° F in a cold chamber. A prescribed layer of ice is applied to the windshield. The defroster is then run, and the advancing melt boundary marked as the test proceeds.

The SAE prescribed area of the windshield was 100% cleared and the side windows were 75% cleared within the specified 30-minute period.

Defrost Results

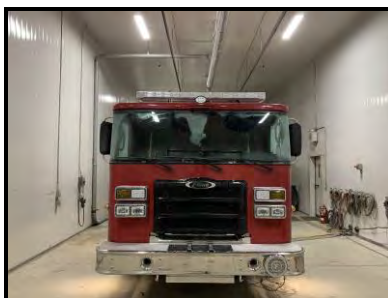
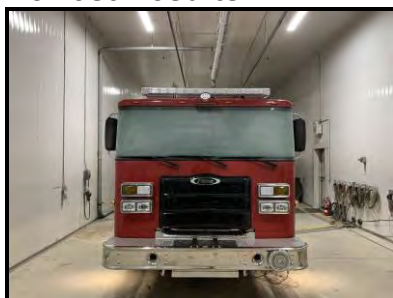

Start of Test

15 Minutes

30 Minutes



Right

Viewed From Outside

Left

VALIDATION TEST: MCC Test Report TR#19-0047 R00

Pierce Manufacturing, Inc.

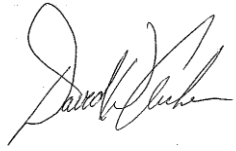

David W. Archer
Vice President of Engineering

Mobile Climate Control, Inc.

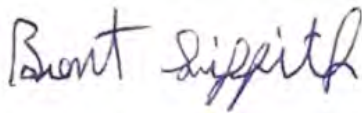

Brent Griffith
Lead Test Engineer & Large Application Specialist

Pierce Manufacturing

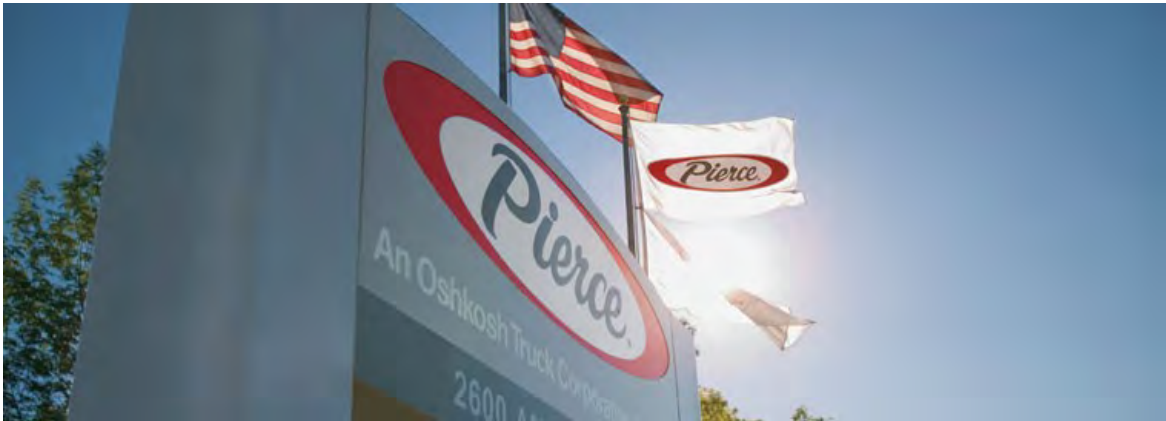



CERTIFICATE OF LIABILITY INSURANCE

DATE (MM/DD/YYYY)
03/19/2018

THIS CERTIFICATE IS ISSUED AS A MATTER OF INFORMATION ONLY AND CONFERS NO RIGHTS UPON THE CERTIFICATE HOLDER. THIS CERTIFICATE DOES NOT AFFIRMATIVELY OR NEGATIVELY AMEND, EXTEND OR ALTER THE COVERAGE AFFORDED BY THE POLICIES BELOW. THIS CERTIFICATE OF INSURANCE DOES NOT CONSTITUTE A CONTRACT BETWEEN THE ISSUING INSURER(S), AUTHORIZED REPRESENTATIVE OR PRODUCER, AND THE CERTIFICATE HOLDER.

IMPORTANT: If the certificate holder is an ADDITIONAL INSURED, the policy(ies) must have ADDITIONAL INSURED provisions or be endorsed. If SUBROGATION IS WAIVED, subject to the terms and conditions of the policy, certain policies may require an endorsement. A statement on this certificate does not confer rights to the certificate holder in lieu of such endorsement(s).

PRODUCER Hays Companies 1200 North Mayfair Road, Suite 100 Milwaukee, WI 53226	1-414-443-0000	CONTACT NAME: PHONE (A/C, No, Ext): E-MAIL ADDRESS:	FAX (A/C, No):
INSURED Pierce Manufacturing Inc. P.O. Box 2017 Appleton, WI 54912-2017		INSURER(S) AFFORDING COVERAGE	
		INSURER A: NATIONAL FIRE & MARINE INS CO	NAIC# 20079
		INSURER B: TRAVELERS PROPERTY CAS CO OF AMER	25674
		INSURER C: PHOENIX INS CO	25623
		INSURER D: BERKLEY NATL INS CO	38911
		INSURER E:	
		INSURER F:	

COVERAGES CERTIFICATE NUMBER: 52318109 REVISION NUMBER:

THIS IS TO CERTIFY THAT THE POLICIES OF INSURANCE LISTED BELOW HAVE BEEN ISSUED TO THE INSURED NAMED ABOVE FOR THE POLICY PERIOD INDICATED. NOTWITHSTANDING ANY REQUIREMENT, TERM OR CONDITION OF ANY CONTRACT OR OTHER DOCUMENT WITH RESPECT TO WHICH THIS CERTIFICATE MAY BE ISSUED OR MAY PERTAIN, THE INSURANCE AFFORDED BY THE POLICIES DESCRIBED HEREIN IS SUBJECT TO ALL THE TERMS, EXCLUSIONS AND CONDITIONS OF SUCH POLICIES. LIMITS SHOWN MAY HAVE BEEN REDUCED BY PAID CLAIMS.

INSR LTR	TYPE OF INSURANCE	ADDL INSD	SUBR WVD	POLICY NUMBER	POLICY EFF (MM/DD/YYYY)	POLICY EXP (MM/DD/YYYY)	LIMITS
A	<input checked="" type="checkbox"/> COMMERCIAL GENERAL LIABILITY <input type="checkbox"/> CLAIMS-MADE <input checked="" type="checkbox"/> OCCUR GEN'L AGGREGATE LIMIT APPLIES PER: <input checked="" type="checkbox"/> POLICY <input type="checkbox"/> PRO-JECT <input type="checkbox"/> LOC OTHER:	X		42-GLO-100190-04	04/01/18	04/01/19	EACH OCCURRENCE \$ 1,000,000 DAMAGE TO RENTED PREMISES (Ea occurrence) \$ 500,000 MED EXP (Any one person) \$ Excluded PERSONAL & ADV INJURY \$ 1,000,000 GENERAL AGGREGATE \$ 5,000,000 PRODUCTS - COMP/OP AGG \$ 1,000,000 \$
B	<input checked="" type="checkbox"/> AUTOMOBILE LIABILITY <input checked="" type="checkbox"/> ANY AUTO <input type="checkbox"/> OWNED AUTOS ONLY <input type="checkbox"/> HIRED AUTOS ONLY <input type="checkbox"/> SCHEDULED AUTOS NON-OWNED AUTOS ONLY			TJCAP118D2004TIL17	10/01/17	10/01/18	COMBINED SINGLE LIMIT (Ea accident) \$ 1,000,000 BODILY INJURY (Per person) \$ BODILY INJURY (Per accident) \$ PROPERTY DAMAGE (Per accident) \$ \$
A	<input checked="" type="checkbox"/> UMBRELLA LIAB <input checked="" type="checkbox"/> OCCUR <input type="checkbox"/> EXCESS LIAB <input type="checkbox"/> CLAIMS-MADE DED RETENTION \$			42-UMO-100191-04	04/01/18	04/01/19	EACH OCCURRENCE \$ 15,000,000 AGGREGATE \$ 15,000,000 \$
B	<input checked="" type="checkbox"/> WORKERS COMPENSATION AND EMPLOYERS' LIABILITY <input type="checkbox"/> ANY PROPRIETOR/PARTNER/EXECUTIVE OFFICER/MEMBER EXCLUDED? (Mandatory in NH) If yes, describe under DESCRIPTION OF OPERATIONS below		Y/N	TRJUB117D757717	10/01/17	10/01/18	<input checked="" type="checkbox"/> PER STATUTE <input type="checkbox"/> OTHER E.L. EACH ACCIDENT \$ 1,000,000 E.L. DISEASE - EA EMPLOYEE \$ 1,000,000 E.L. DISEASE - POLICY LIMIT \$ 1,000,000
C	<input type="checkbox"/> N/A N/A			TC2NUB117D756517	10/01/17	10/01/18	
D	<input type="checkbox"/> Excess Liability			CRX0960017405	04/01/18	04/01/19	Ea Occ/Agg 10,000,000

DESCRIPTION OF OPERATIONS / LOCATIONS / VEHICLES (ACORD 101, Additional Remarks Schedule, may be attached if more space is required)
Additional Insured when required by written contract.

CERTIFICATE HOLDER Front Range Fire Apparatus 7600 Miller Court Longmont, CO 80504	CANCELLATION SHOULD ANY OF THE ABOVE DESCRIBED POLICIES BE CANCELLED BEFORE THE EXPIRATION DATE THEREOF, NOTICE WILL BE DELIVERED IN ACCORDANCE WITH THE POLICY PROVISIONS. AUTHORIZED REPRESENTATIVE <i>Dan J. Squire</i>
---	---

LICENSE



License #: 9233

This Certifies

Is duly licensed
as a motor vehicle/
powersports

PIERCE MANUFACTURING INC
Motor Vehicle Manufacturer

This license is issued under the provisions of Title 12, Article 6, Colorado Revised Statutes.

PIERCE MANUFACTURING INC
120 S. Central Ave., Suite 400
Saint Louis MO 63105



Issued 11/01/2017 Expires 10/31/2018

Michael Hartman
EXECUTIVE DIRECTOR
Department of Revenue

Display at place of business

OFFICE OF THE SECRETARY OF STATE
OF THE STATE OF COLORADO

CERTIFICATE OF FACT OF GOOD STANDING

I, Wayne W. Williams, as the Secretary of State of the State of Colorado, hereby certify that, according to the records of this office,

Pierce Manufacturing Company

is an entity formed or registered under the law of Tennessee, has complied with all applicable requirements of this office, and is in good standing with this office. This entity has been assigned entity identification number 20171636101 and has provided the assumed entity name for use in Colorado

Pierce Corporation

This certificate reflects facts established or disclosed by documents delivered to this office on paper through 08/06/2018 that have been posted, and by documents delivered to this office electronically through 08/08/2018 @ 16:36:43.

I have affixed hereto the Great Seal of the State of Colorado and duly generated, executed, and issued this official certificate at Denver, Colorado on 08/08/2018 @ 16:36:43 in accordance with applicable law. This certificate is assigned Confirmation Number 11052899.



A handwritten signature in blue ink that reads "Wayne W. Williams".

Secretary of State of the State of Colorado

*****End of Certificate*****

Notice: A certificate issued electronically from the Colorado Secretary of State's Web site is fully and immediately valid and effective. However, as an option, the issuance and validity of a certificate obtained electronically may be established by visiting the Validate a Certificate page of the Secretary of State's Web site, <http://www.sos.state.co.us/biz/CertificateSearchCriteria.do> entering the certificate's confirmation number displayed on the certificate, and following the instructions displayed. Confirming the issuance of a certificate is merely optional and is not necessary to the valid and effective issuance of a certificate. For more information, visit our Web site, <http://www.sos.state.co.us/> click "Businesses, trademarks, trade names" and select "Frequently Asked Questions."

Organizational Background and Overview

Pierce Celebrates Its 100th Year in Business

Pierce Manufacturing, an Oshkosh Corporation (NYSE:OSK) company, and the leading U.S. manufacturer of fire and emergency vehicles, is celebrating its 100th Anniversary in 2013. Pierce is kicking off its yearlong commemoration by launching a special website section located at www.piercemfg.com/100thAnniversary. The site features an interactive historical timeline, a 100th Anniversary video, a photo contest, limited edition merchandise, and upcoming events.

“Pierce is a company with humble beginnings, a rich history, and an exciting future,” said Jim Johnson, Oshkosh Corporation executive vice president and president of the Fire & Emergency segment and Pierce Manufacturing. “It is significant that only a small fraction of companies from any industry achieve the 100 year milestone. On behalf of Pierce employees, and all those who preceded us, we pledge an unwavering level of commitment to firefighters, and boldness in our thinking, as we look ahead to the next hundred years.”

Founded in 1913 by Humphrey and Dudley Pierce in Appleton, Pierce Manufacturing first built after-market bodies for Ford Model T chassis. In 1939, the company manufactured its first fire truck body and grew to 20 employees. In 1958, ushering in a new era of boom and platform vehicles, Pierce designed the first ever articulating aerial apparatus that was used to reach up and over tall obstructions. Pierce introduced its first custom chassis and body – the Arrow – in 1982, and that design changed the face of the modern fire industry. Pierce Manufacturing has built 51,650 fire trucks and 27,000 custom chassis.

Pierce manufactures pumpers, tankers, aerials, wildland pumpers, rescues, hazmat, and communication vehicles.

More recent examples of Pierce innovations include industry firsts like the **Dash® CF** fire apparatus (that features an innovative cab-forward design), frontal airbag and the side roll protection systems, and the patented **Pierce Ultimate Configuration (PUC)** response vehicle. Other examples include **Command Zone™** advanced electronics to enhance vehicle troubleshooting and reliability, and **TAK-4®** independent front suspension for unmatched vehicle maneuverability. Pierce engineers and manufactures its own **Husky® foam** and **Hercules®** compressed air foam systems that more effectively attack and suppress structural, wildland, automobile, and fuel fires. Every vehicle component is designed to help firefighters perform safely at their highest level.

“The more than 2,000 people who work for Pierce, including many families with multiple generations of service, are our backbone – and the reason for our longevity, success and growth,” added Johnson. “Pierce employees think of their work as more of a vocation than a job, and the average employee tenure is nearly 20 years. That speaks volumes.”

Pierce markets its products through the industry’s largest and most comprehensive dealer and service network. The company enjoys a nationwide web of dealerships with over 600 certified and factory trained Service Brigade technicians and over 50 service centers. Pierce also offers custom training sessions for fire departments.

Oshkosh Capital offers lease purchases which can range from 3, 5, 7 or 10 year terms.



About Pierce Manufacturing

Pierce Manufacturing Inc., an Oshkosh Corporation [NYSE: OSK] company, is celebrating its 100th year in business in 2013. Pierce is the leading North American manufacturer of custom fire apparatus. Products include custom and commercial pumpers, aerials, rescue trucks, wildland trucks, mini-pumpers, elliptical tankers, and homeland security apparatus. In addition, Pierce designs its own foam systems and was the first company to introduce frontal airbags and the Side Roll Protection system to fire apparatus. To learn more about Pierce, visit www.piercemfg.com.

About Oshkosh Corporation

Oshkosh Corporation is a leading designer, manufacturer and marketer of a broad range of specialty access equipment, commercial, fire & emergency and military vehicles and vehicle bodies. Oshkosh Corporation manufactures, distributes and services products under the brands of Oshkosh®, JLG®, Pierce®, McNeilus®, Jerr-Dan®, Frontline™, CON-E-CO®, London® and IMT®. Oshkosh products are valued worldwide in businesses where high quality, superior performance, rugged reliability and long-term value are paramount. For more information, visit www.oshkoshcorporation.com.

®, TM All brand names referred to in this news release are trademarks of Oshkosh Corporation or its subsidiary companies.

Pierce Manufacturing Inc.

AN OSHKOSH CORPORATION COMPANY • ISO 9001:2000 CERTIFIED



2600 AMERICAN DRIVE
POST OFFICE BOX 2017
APPLETON, WISCONSIN 54912-2017
920-832-3000
www.piercemfg.com

October 8, 2013

Re: Pierce Authorized Dealership

To whom it may concern:

Front Range Fire Apparatus with its corporate location at 7600 Miller Ct, Frederick West Business Park, Longmont, CO 80504 is an authorized Pierce Manufacturing, Inc. dealership. Front Range is the only dealership authorized to sell Pierce apparatus in the states of Wyoming, Nebraska, and Colorado and is the sole source for Pierce fire/rescue apparatus in those areas. Front Range Fire Apparatus has been representing Pierce Manufacturing, Inc. since 1985 and has the authorization to sign bid documents on Pierce's behalf. If you have questions, or need further information, please feel free to contact me.

Yours very truly,

PIERCE MANUFACTURING, INC.

A handwritten signature in cursive script that reads "David J. Stoffel".

David J. Stoffel

Sr. Manager, Order Management

**Environmental Protection Department
Environmental Management Practice
Pierce Manufacturing Inc.**

At Pierce Manufacturing Inc. (Pierce), a subsidiary of Oshkosh Corporation, the primary responsibility of the Environmental Protection Department is to provide oversight to ensure that all facilities and company activities continue to operate in compliance with applicable environmental laws and regulations. Specifically, Pierce facilities are subject to State and Federal regulatory programs that involve issues such as air quality, waste generation and disposal, process wastewater, storm water management, underground/aboveground storage tanks, and emergency planning and community right-to-know. Regulations that apply to company activities are contained in the Environmental Protection Agency regulations of Chapter 40 Code of Federal Regulations, Department of Transportation Regulations in Chapter 49 Code of Federal Regulations, Environmental Protection Regulations in the Wisconsin NR Rules, and state/local wastewater and storm drainage rules. The Pierce facilities are in compliance with these applicable regulations including applicable ozone-depleting substances regulations.

As required by these environmental regulatory programs, Pierce Environmental Protection Department personnel perform weekly and/or monthly assessments, inspections, and recordkeeping activities. In addition to these internal inspections, our facilities are inspected by Federal, State, and Local environmental agencies. Pierce has an outstanding compliance history, and a good working relationship with these agencies. Pierce was acquired by Oshkosh Truck in September 1996. Since that time, Pierce has not had any environmental fines or penalties, and Pierce has a good working relationship with the Wisconsin Department of Natural Resources (WDNR). Pierce had voluntarily committed to reducing Volatile Organic Compounds (VOCs) and conducted extensive research on the reformulation of the hundreds of different paints Pierce uses. As a result, Pierce was the first Wisconsin manufacturer in the industry to successfully use low VOC coatings, and has received two environmental protection awards for doing so. In August 2000, Pierce was nominated by the WDNR and received the WDNR's Prevention/Environment/Prosperity (PEP) Award for their innovative paint emission reduction program. In May 2001, Pierce was presented with the Wisconsin Business Friend of the Environment Award in recognition of Pierce's leadership in environmental protection.



FIRE APPARATUS MANUFACTURERS' ASSOCIATION

P.O. Box 387 • Lynnfield, MA 01940-0387 • Phone/Fax: (781) 334-2911

January 8, 2004

To Whom It May Concern:

This letter will verify that Pierce Manufacturing, Inc. has
been a member of the Fire Apparatus Manufacturers' Association
(FAMA) since 1968.

Very truly yours,

Karen H. Burnham
Administrative Assistant

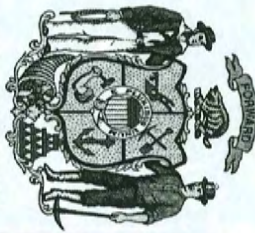

DEPARTMENT OF
FINANCIAL INSTITUTIONS

STATE OF WISCONSIN
DEPARTMENT OF TRANSPORTATION
DIVISION OF MOTOR VEHICLES

MOTOR VEHICLE DEALER - RECREATIONAL VEHICLE DEALER
SALES FINANCE - MANUFACTURER - DISTRIBUTOR
LICENSE CERTIFICATE



The person, firm or corporation whose name appears on this license has complied with the requirements of Wisconsin statutes and is hereby licensed to engage in business as a motor vehicle dealer sales finance company and / or as a motor vehicle dealer, recreational vehicle dealer, manufacturer, or distributor to sell, manufacture or distribute the makes of vehicles printed below.

This license and your license plates cannot be assigned or transferred.

If there is a change of ownership or if licensee discontinues business at this location this certificate and all dealer's license plates of the number shown hereon must be returned immediately for cancellation.

LICENSE NUMBER
MMV-6025

ISSUED
02/01/2018

EXPIRES
01/31/2020

BRANCH / SUBLOT

MAKES
PRICE

PIERCE MANUFACTURING INC
2600 AMERICAN DR
APPLETON WI 54914-9010

Mailing addr exists 63105

MV1045 10/2008

POST IN A CONSPICUOUS PLACE

The Fire Apparatus Manufacturers Association,

in accordance with its bylaws affirms



meets the membership for the year 1996

in witness whereof, the officers of this Association

Paul W. Brown

IFAFMA President

IFAFMA Membership Chairman



MANUFACTURING INC.

TO: WHOM IT MAY CONCERN
FROM: Ken Kamprath - Chief Engineer R&D
DATE: November 5, 1996
SUBJECT: Second Generation Body Design and Test

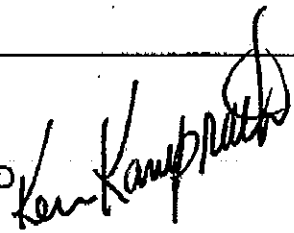

The Pierce Second Generation body has completed extensive design analysis and performance testing. Both aluminum and steel body constructions were evaluated. The testing was completed in July of 1994. The testing consisted of three phases: modal analysis, brittle lacquer coating and strain gaging.

Modal analysis is a computerized vibration analysis tool used to generate animated mode shapes. A shaker is attached to the truck frame to generate the simulated vibrations. The animated mode shapes give a computerized "picture" of what the body goes through during actual vibration and shock loading. The animated mode shape shows the areas of dissimilar (not normal) motion on the body. This helps the engineer "zero in" on potential areas of high stress concentration.

Once these areas are determined, a brittle lacquer coating is applied to the body surface. The vehicle is taken through a series of in-lab and on-road test events to generate "crazing" of the brittle lacquer. The "crazing" shows the stress concentration location and direction. Now the engineer can apply a strain gage to measure the exact material stress occurring at the exact point of maximum stress concentration.

The Second Generation body used over 30 strain gages to verify the structural toughness. The strain gages were applied to the body sheet metal as well as the supporting substructure. The test vehicles were subjected to 9 inch blocks placed diagonally under one front wheel and one rear wheel. The vehicle was severely twisted to simulate the motions a vehicle sees when exiting off a driveway apron and onto the roadway when responding to an emergency call. In addition the vehicle was driven over severe bumps, through turns and evasive maneuvers. Acceleration, deceleration and hard stops were performed. During all of the in-lab and on-road test events, the strain gage data was collected with on-board computerized data acquisition equipment. All of the data was collected "real time" or as the event was happening.

The Pierce Second Generation body was thoroughly tested using proven computerized methods. In addition the bodies were tested over actual road events to assure many years of satisfying service.



LICENSE



License #: 200

This Certifies
Is duly licensed
as a motor vehicle/
powersports

**FRONT RANGE FIRE APPARATUS
Franchised Motor Vehicle Dealer**

Issued **10/01/2021** Expires **09/30/2022**

This license is issued under the provisions of Title 44, Article 20, Colorado Revised Statutes.

**FRONT RANGE FIRE APPARATUS
7600 MILLER CT
Frederick CO 80504**

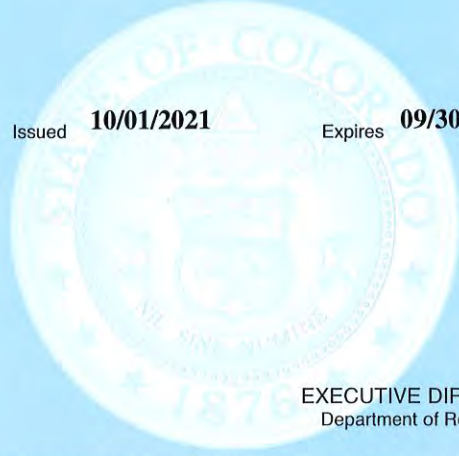

EXECUTIVE DIRECTOR
Department of Revenue

Display at place of business

ALL INFORMATION LISTED ON THIS LICENSE APPLIES TO THE LICENSEE NAMED ABOVE

Owners OK to Sell:

Demo Plates: Y

Full Use Plates: N

Primary Location:

7600 MILLER CT, FREDERICK CO 80530-0000

Additional Location(s)

OFFICE OF THE SECRETARY OF STATE
OF THE STATE OF COLORADO

CERTIFICATE OF FACT OF GOOD STANDING

I, Jena Griswold, as the Secretary of State of the State of Colorado, hereby certify that, according to the records of this office,

FRONT RANGE FIRE APPARATUS, LIMITED

is a
Corporation

formed or registered on 08/26/1985 under the law of Colorado, has complied with all applicable requirements of this office, and is in good standing with this office. This entity has been assigned entity identification number 19871634538 .

This certificate reflects facts established or disclosed by documents delivered to this office on paper through 03/08/2022 that have been posted, and by documents delivered to this office electronically through 03/09/2022 @ 15:37:35 .

I have affixed hereto the Great Seal of the State of Colorado and duly generated, executed, and issued this official certificate at Denver, Colorado on 03/09/2022 @ 15:37:35 in accordance with applicable law. This certificate is assigned Confirmation Number 13854934 .



A handwritten signature in blue ink that reads "Jena Griswold".

Secretary of State of the State of Colorado

*****End of Certificate*****

Notice: A certificate issued electronically from the Colorado Secretary of State's Web site is fully and immediately valid and effective. However, as an option, the issuance and validity of a certificate obtained electronically may be established by visiting the Validate a Certificate page of the Secretary of State's Web site, <http://www.sos.state.co.us/biz/CertificateSearchCriteria.do> entering the certificate's confirmation number displayed on the certificate, and following the instructions displayed. Confirming the issuance of a certificate is merely optional and is not necessary to the valid and effective issuance of a certificate. For more information, visit our Web site, <http://www.sos.state.co.us/> click "Businesses, trademarks, trade names" and select "Frequently Asked Questions."

Pierce Manufacturing Inc.

AN OSHKOSH CORPORATION COMPANY • ISO 9001:2000 CERTIFIED



2600 AMERICAN DRIVE
POST OFFICE BOX 2017
APPLETON, WISCONSIN 54912-2017
920-832-3000
www.piercemfg.com

October 8, 2013

Re: Pierce Authorized Dealership

To whom it may concern:

Front Range Fire Apparatus with its corporate location at 7600 Miller Ct, Frederick West Business Park, Longmont, CO 80504 is an authorized Pierce Manufacturing, Inc. dealership. Front Range is the only dealership authorized to sell Pierce apparatus in the states of Wyoming, Nebraska, and Colorado and is the sole source for Pierce fire/rescue apparatus in those areas. Front Range Fire Apparatus has been representing Pierce Manufacturing, Inc. since 1985 and has the authorization to sign bid documents on Pierce's behalf. If you have questions, or need further information, please feel free to contact me.

Yours very truly,

PIERCE MANUFACTURING, INC.

A handwritten signature in cursive script that reads "David J. Stoffel".

David J. Stoffel

Sr. Manager, Order Management

PIERCE MANUFACTURING INC.

AN OSHKOSH TRUCK CORPORATION COMPANY • ISO 9001 CERTIFIED

2600 AMERICAN DRIVE
POST OFFICE BOX 2017
APPLETON, WISCONSIN 54913-2017
920-832-3000 • FAX 920-832-3208



April 4, 2002

To Whom It May Concern:

This letter is verification that Front Range Fire Apparatus, LTD. is an official Pierce Manufacturing authorized repair facility.

Sincerely,
Pierce Manufacturing Inc.



Joe Barry
Technical Service Manager



Service Center



7600 Miller Ct. Frederick, Colorado
303-449-9911



Service Facility

The industry leading service facility at Front Range Fire Apparatus offers complete maintenance, inspections, and repair on emergency rescue apparatus, including non-Pierce and non-AEV apparatus. Whether it's basic preventative maintenance or complete restorations, our technicians take great pride in providing all the services you need to keep your fleet ready.

Our service facility is fully insured and staffed by Pierce Master Technicians that are EVT and ASE certified, as well as stocked with state-of-the-art equipment, including diagnostic software, truck lifts, and a mobile draft commander pump test trailer. The facility consists of over 15,000 square feet with room for up to 14 apparatus.

MEET THE TEAM



ASHER STRAW

General Manager

AsherS@fronrangefire.com



SEAN BLATZER

Service Manager

SeanB@fronrangefire.com



DOUG BEAM

Technical Support/Warranty

DougB@fronrangefire.com



KENT MCCREARY

Service Writer

KentM@fronrangefire.com



Service Technicians

BRAD SHAEFER

CLYDE BOWERS

EVAN BAIER

IVAN GONZALEZ

FREDDY NUANES

www.fronrangefire.com

7600 Miller Court

Frederick, CO 80504

303-449-9911

info@fronrangefire.com

**Proudly serving the fire service industry
for over 45 years.**



**GENERAL MAINTENANCE, SERVICE REPAIRS, AND INSPECTIONS
ON ALL MAKES AND MODELS OF FIRE APPARATUS.**

Service, Repair , and Installation

Generator

Air brake

CAFS and foam system

Fire Pump

Tank

Electrical

Steel water and UPF poly tank

Onboard battery chargers

Air systems

Custom Welding and Fabrication

Steel

Aluminum

UL Inspection and Repair

Aerial Service and Repair

Structural

Hydraulic

Electrical

Apparatus Body and Accident Repair

...and more!



Whether your truck is out of service with a major repair issue or just needs an oil change, our service technicians are here for you.



Mobile Service

Apparatus training

Service contracts

Customized preventative maintenance programs

Annual pump tests and acceptance tests

Certified pump, plumbing and valve repairs

CAFS and foam system installation

Electrical system repairs and upgrades

Air brake maintenance repair and service

Aerial maintenance and repair



18th Annual Fire Leadership Challenge

**Extraordinary Leadership
in Turbulent Times**

Certificate of Appreciation

Presented To

Front Range Fire Apparatus

*For participation in and support of
The Colorado State Fire Chiefs Association
19th Annual Leadership Challenge*

December 5, 2009

Chris Riley - Colorado State Fire Chiefs Association

Dave Parmley - Conference Chair



Organized December 23, 1916

Colorado State Fire Fighters Association

Certificate of Membership

To Whom It May Concern, Greetings:

This Certifies That **Front Range Fire Apparatus**

Having complied with all the requirements of the Constitution and By-Laws of the Colorado State Fire Fighters Association, is hereby declared an Associate Member and is entitled to all Rights, Privileges and Benefits of Associate Membership in said Association.

June 16 / 2007
Date

[Signature]
President

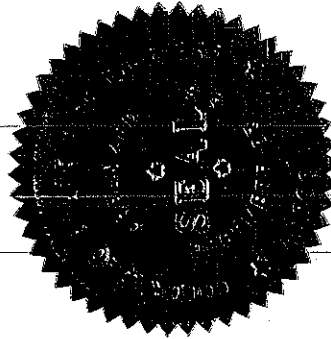

Bob [Signature]
Treasurer

[Signature]
Secretary

STATE OF COLORADO

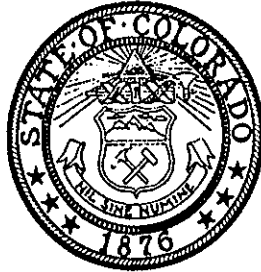

DEPARTMENT OF
STATE

CERTIFICATE

I, NATALIE MEYER, Secretary of State of the State of Colorado hereby certify that the prerequisites for the issuance of this certificate have been fulfilled in compliance with law and are found to conform to law.

Accordingly, the undersigned, by virtue of the authority vested in me by law, hereby issues A CERTIFICATE OF INCORPORATION
TO FRONT RANGE FIRE APPARATUS, LIMITED.

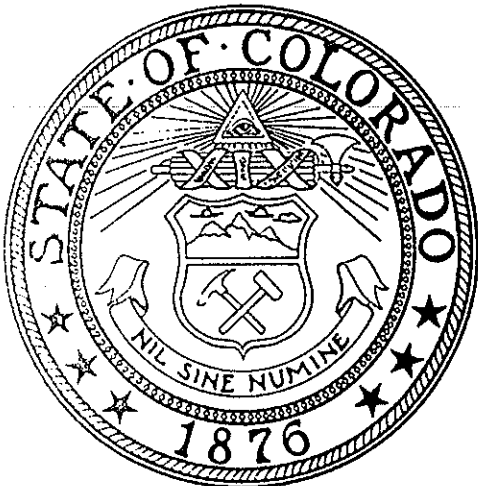

Natalie Meyer
SECRETARY OF STATE

DATED: AUGUST 26, 1985

Front Range Fire Apparatus Sales & Operations

Duane Doucette

Owner
Truck Sales Rep
Denver/Metro Area
Cell: (303) 304-6118
Office: (303) 449-9911 x 121
DuaneD@FrontRangeFire.com



Wayne Kerber

Truck Sales Rep.
North Western Colorado/ Mountains
Cell: 970-531-7184
WayneK@FrontRangeFire.com



Jennifer Doucette

Business Operations Manager
Cell: (303) 304-6118
Office: (303) 449-9911 x 130



Don Chapman

Truck Sales Rep
Colorado/Mountains
Cell: 719-588-1580
DonC@FrontRangeFire.com



Mark Balch

Ambulance Sales Rep. Colorado Cell:
303-883-7860
Office: 303-449-9911 x 122
MarkB@FrontRangeFire.com



Jason Byrne

Truck Sales Rep
Cell: 303-929-0079
JasonB@FrontRangeFire.com



Rose Cain

Bookkeeper
Office: 303-449-9911 x 111
RoseC@FrontRangeFire.com

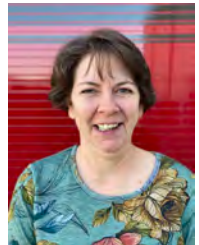

Margaret Straw

Special Projects Coordinator
Office: 303-449-9911 x 27
MargaretS@FrontRangeFire.com



Front Range Fire Apparatus Service

Asher Straw

Service Manager

Office: 303-449-9911 x 112

Cell: 720-202-4286

AsherS@FrontRangeFire.com



Sean Blatzer

Service Manager

Office: 303-449-9911 x 115

SeanB@FrontRangeFire.com



Doug Beam

Technical Support/Warrantyport

Office: 303-449-9911 x 120

Cell: 303-475-5371

DougB@FrontRangeFire.com



Parts

Office: 303-449-9911 x 165